



Z1 370Z / G37 AIR INTAKE UPGRADE KIT INSTALLATION MANUAL



This Installation Manual is intended for the following models:

2009-2020	Nissan 370Z
2008-2015	Infiniti G37
2014-2016	Infiniti Q60

PROLOGUE:

Study these instructions completely before proceeding to assembly. The installer must have a thorough knowledge of automotive systems operation. If unfamiliar with any of the concepts outlined in this instruction, we recommend the installation be completed by a qualified professional.

WARNING!

Extreme caution should be taken when performing maintenance or performance upgrades to your vehicle. Please observe and abide by any Warning or Caution labels placed on the various components and tools used when servicing your vehicle. If you have any questions regarding installation or the various components included with the Z1 Motorsports 370Z / G37 Air Intake Upgrade Kit, consult with a Professional Mechanic or contact Z1 Motorsports for more information.

PRODUCT OPTIONS:

SILICONE COUPLERS:

Black
Red
Blue



Item	Quantity	Description
1	2	Pop Charger Filter Element with Clamp
2	2	Velocity Stack with Hardware
3	2	3.0" Velocity Stack Upgrade Adapter
Z1 Upgrade Kit		
Item	Quantity	Description
4	2	Hose Clamp, 3"
5	2	Hose Clamp, 2.5"
6	2	Silicone Reducer, 3"
Stillen Upgrade Kit		
Item	Quantity	Description
7	4	Hose Clamp, 3"
8	2	Silicone Coupler, 3"

TOOLS REQUIRED:

- Hydraulic Jack
- (2) 2-Ton (or greater) Jack Stands
- Ratchet
- Ratchet Extension(s)
- Wheel Chock
- Flat-head Screwdriver
- Gloves
- Silicone Spray
- 10mm Socket
- 14mm Socket
- 8mm Nut Driver

SAFETY REQUIREMENTS:

- Always wear safety glasses and any necessary protective garments. If using any fluids, chemicals, or solvents, a respirator is recommended.
- Always use properly rated jack stands when working under your vehicle.
- Always keep limbs and parts away from moving drivetrain parts.
- Only operate drivetrain in safe space and well-ventilated areas.

BEFORE YOU BEGIN:

Remove contents from the Z1 Motorsports 370Z / G37 Air Intake Upgrade Kit and verify that ALL necessary hardware is present.

PROCEDURE:

1. Place the transmission in Park position (or in Reverse gear if equipped with a manual transmission). Apply the parking brake.
2. Open and support hood of vehicle.
3. Release tension on front lug nuts but **DO NOT** remove them.
4. Locate proper jacking points on vehicle's chassis (refer to vehicle's Owner Manual). Raise and support vehicle using jack & jack stands.
5. Remove front lug nuts and wheels.

370Z Owners: Use Figure 1 below as reference for Steps 6-12. G37 Owners can skip to Step 13.

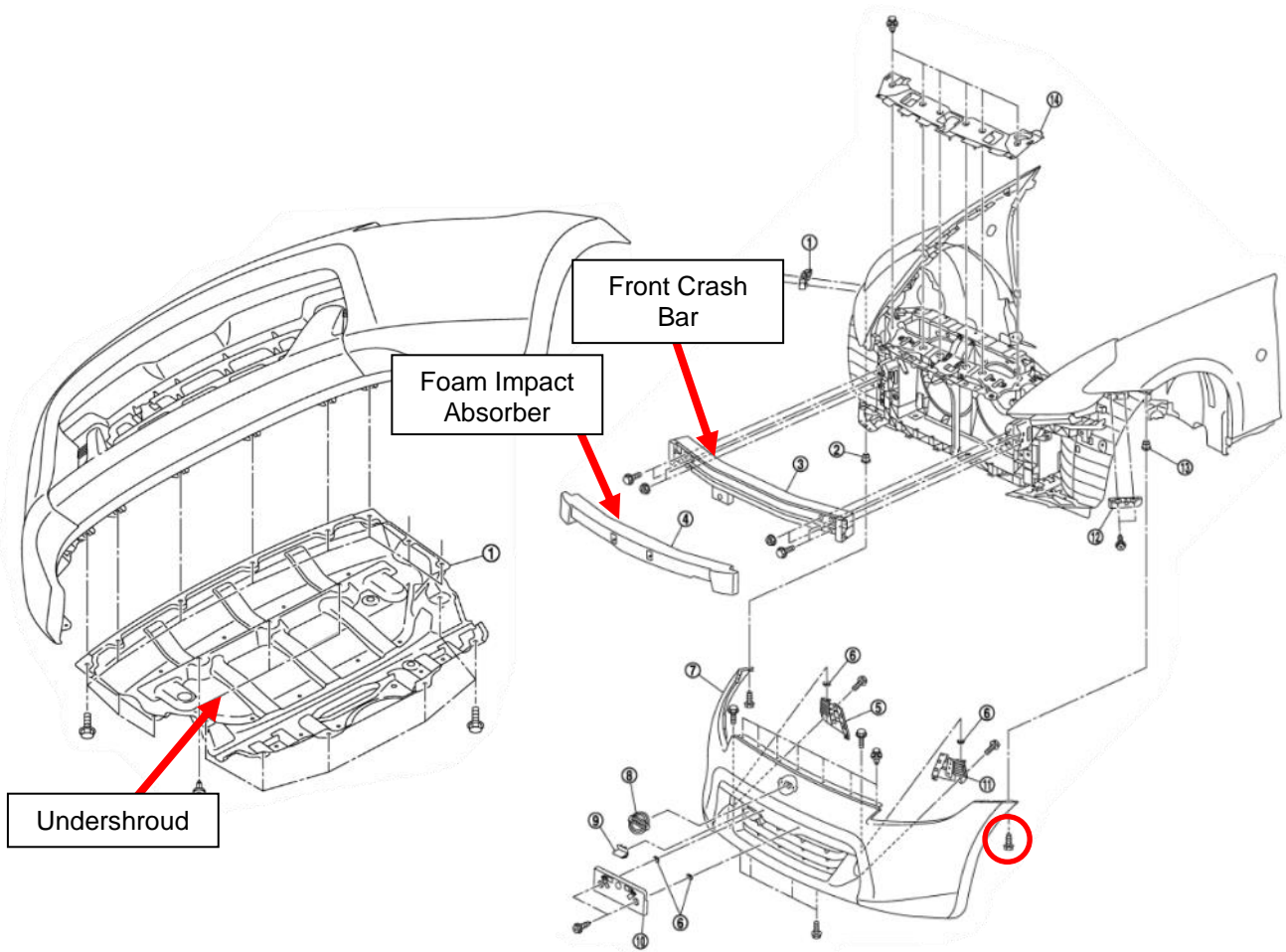

Figure 1

6. Remove the Lower Engine Splash Shield (Undershroud). Fasteners will be an assortment of 10mm screws and plastic panel clips. Use a flat blade screwdriver or trim removal tool to gently pry out the pop clips.
7. Remove plastic clips and the front wheel/fender liners to reveal (1) one mounting screw at each side of the vehicle which mounts the corner of the Bumper Fascia to the vehicle (screw circled in Figure 1 above). Remove mounting screw on each side.
8. Remove (7) seven plastic pop clips securing the Upper Bumper Fascia to the vehicle at radiator core support.

9. With a light pull motion, carefully disengage the Bumper Fascia from the clips on the vehicle just below each headlight. Remove Bumper Fascia and set aside.
10. Remove (8) eight plastic clips which attach Diversion Panel/Radiator Air Guide to Composite Radiator Core Support. Set aside Diversion Panel.
11. Remove the Foam Impact Absorber in front of the Crash Bar.
12. Remove (4) four bolts and (4) four hex nuts securing Front Crash Bar to the chassis, retain the hardware as it will be reused. Remove the Crash Bar.

G37 Owners: Use *Figure 4* below as reference for *Steps 13-20*. 370Z Owners can skip to *Step 21*.

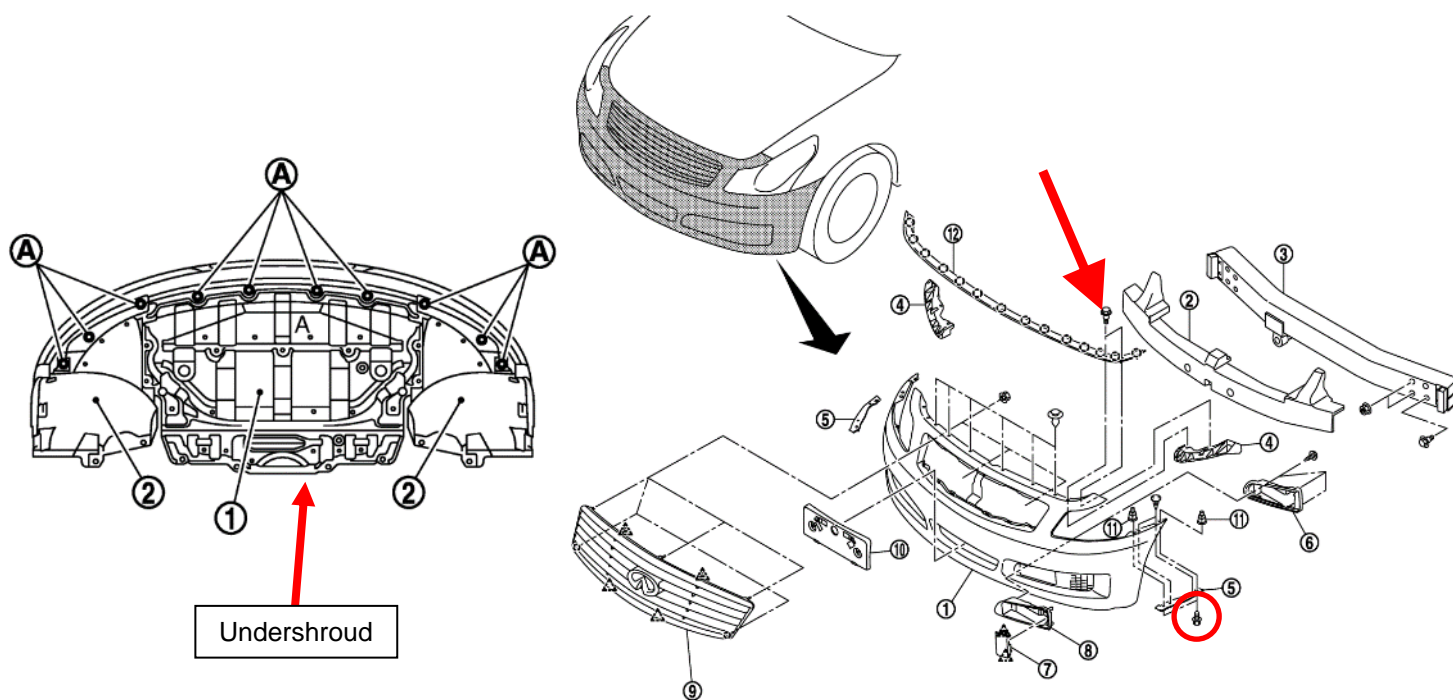

Figure 2

13. Remove the Lower Engine Splash Shield (Undershroud). Fasteners will be an assortment of 10mm screws and plastic panel clips. Use a flat blade screwdriver or trim removal tool to gently pry out the pop clips.
14. Remove plastic clips and the front wheel/fender liners to reveal (2) two mounting screws at each side of the vehicle which mounts corner of the Bumper Fascia to the fender (screw circled in *Figure 2* above). Remove mounting screws on each side.
15. Lift up on the hood seals at the front corner of the engine bay to reveal (2) two mounting screws at each side of the vehicle that mounts the upper corner of Bumper Fascia to the fender (screw shown with arrow above). Remove mounting screws on each side.
16. Remove (6) six plastic pop clips securing the Upper Bumper Fascia to the vehicle at the radiator core support.
17. With a light pull motion, carefully disengage the Bumper Fascia from the clips on the vehicle just below each headlight. Remove Bumper Fascia and set aside.
18. Remove the plastic clips and bolts which attach Diversion Panel/Radiator Air Guide to Composite Radiator Core Support. Set aside Diversion Panel.
19. Remove the Foam Impact Absorber in front of the Crash Bar.
20. Remove (4) four bolts and (4) four hex nuts securing the Front Crash Bar to the chassis, retain the hardware as it will be reused. Remove Crash Bar.

21. Remove the Air Filters from your existing Intake Kit.
22. Install the modified Crash Bar onto the vehicle using the OE Hardware. Optionally you can replace your OE Crash Bar with a [Z1 Bash Bar](#).

NOTE: See images provided at the end of the manual for specifications on how to modify the OEM Front Crash Bar. Z1 also offers a modification service with a 10-day lead time. **DO NOT** drive your vehicle without a front crash bar.

23. Locate the Z1 Air Intake Upgrade Kit components. Place the Z1 Velocity Stack onto the 3" Coupler Adapter. Install (4) four 10mm bolts through the Adaptor and thread them into the Velocity Stack. *Figure 3.*



Figure 3

24. Slide the Silicone Coupler/Reducer and a Hose Clamp over the Velocity Stack Adaptor and tighten the Clamp. *Figure 4.*

NOTE: Use of Silicone Spray can help installation of all Silicone Components.

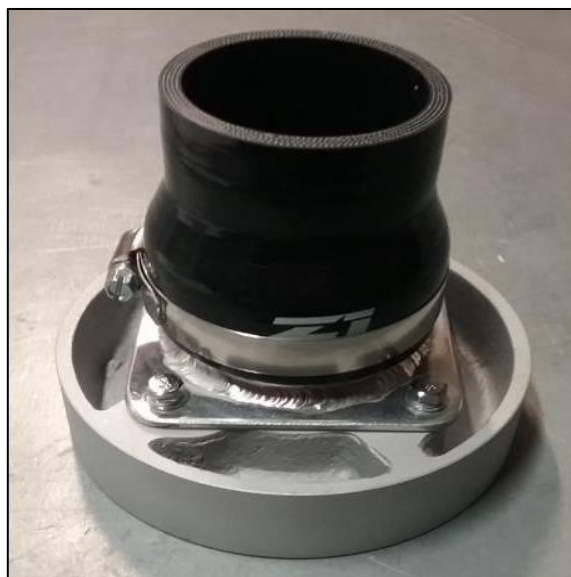

Figure 4

25. Slide the Z1 Air Filter with a Large Hose Clamp over the Velocity Stack and tighten the Hose Clamp. *Figure 5.*



Figure 5

26. Slide coupler/reducer and clamp of the velocity stack assembly over the existing air intake kit opening.

27. Repeat Steps 23-26 for the opposite side Air Filter Assembly.

Completed assembly of 370Z Air Intake Upgrade Kit should look as shown:



Figure 6

28. Start the vehicle. While at idle, check for leaks or faulty operation of the Air Intake Kit.
29. Follow *Steps 3-20* in reverse order to reinstall the Front Bumper.
30. Locate the C.A.R.B. Exemption Sticker. The sticker must be readily visible under the hood in order for an Emissions Inspector to easily see it when the vehicle is required to be tested for emissions. It is **NOT** recommended to affix the label to any equipment that is easily removable from the vehicle. Select a suitable location (Strut Tower, underside of hood, Radiator Shroud, Core Support, etc.). Clean the area to remove all debris and dust and apply the sticker to vehicle. *Figure 7*.



Figure 7

370Z Crash Bar Modification Specifications

NOTE: Nismo model vehicles have a plate riveted to the crash bar (as shown). To utilize the Z1 Air Intake Kit, this plate will need to be modified or removed.

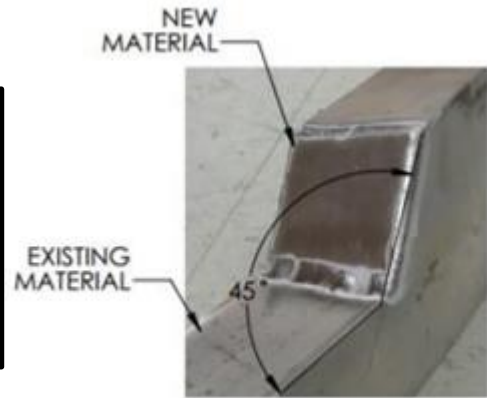
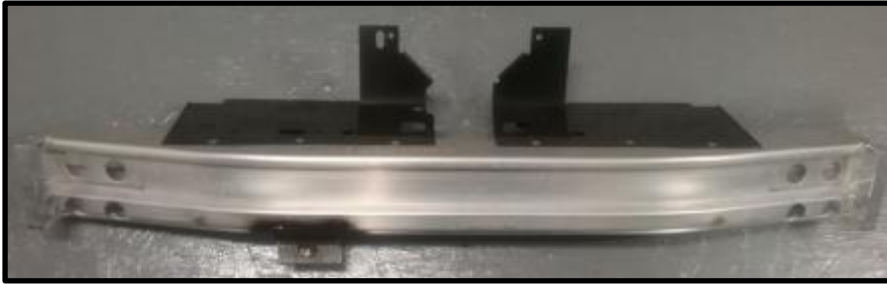

WELDING DETAIL

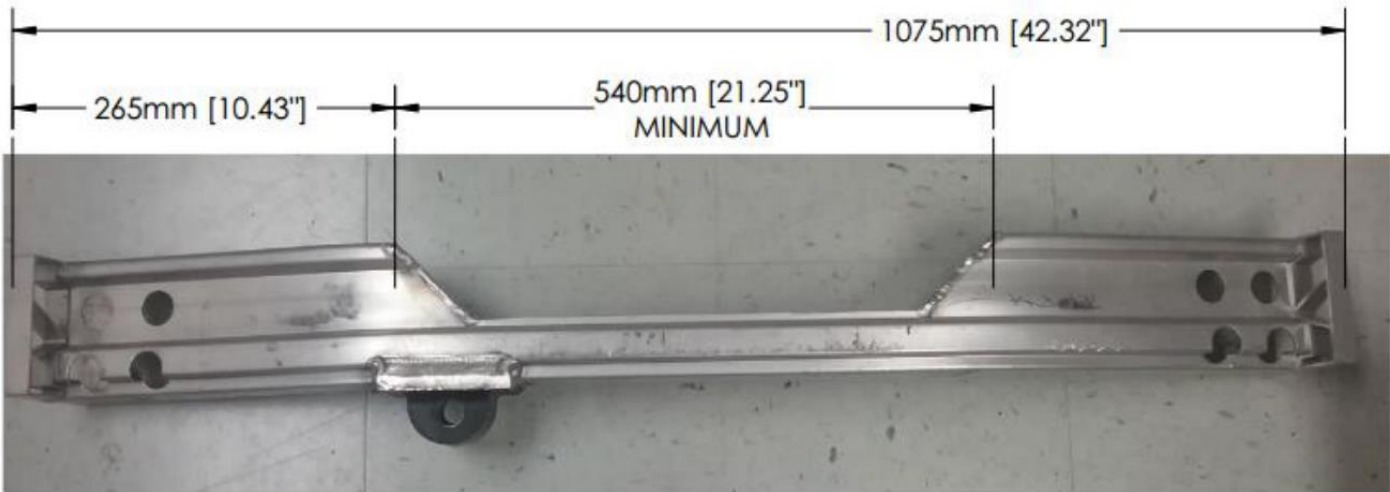

END

Additional Technical Support:

Contact Z1 Motorsports at info@z1motorsports.com
Or call 770-838-7777 between 9am and 6pm ET