

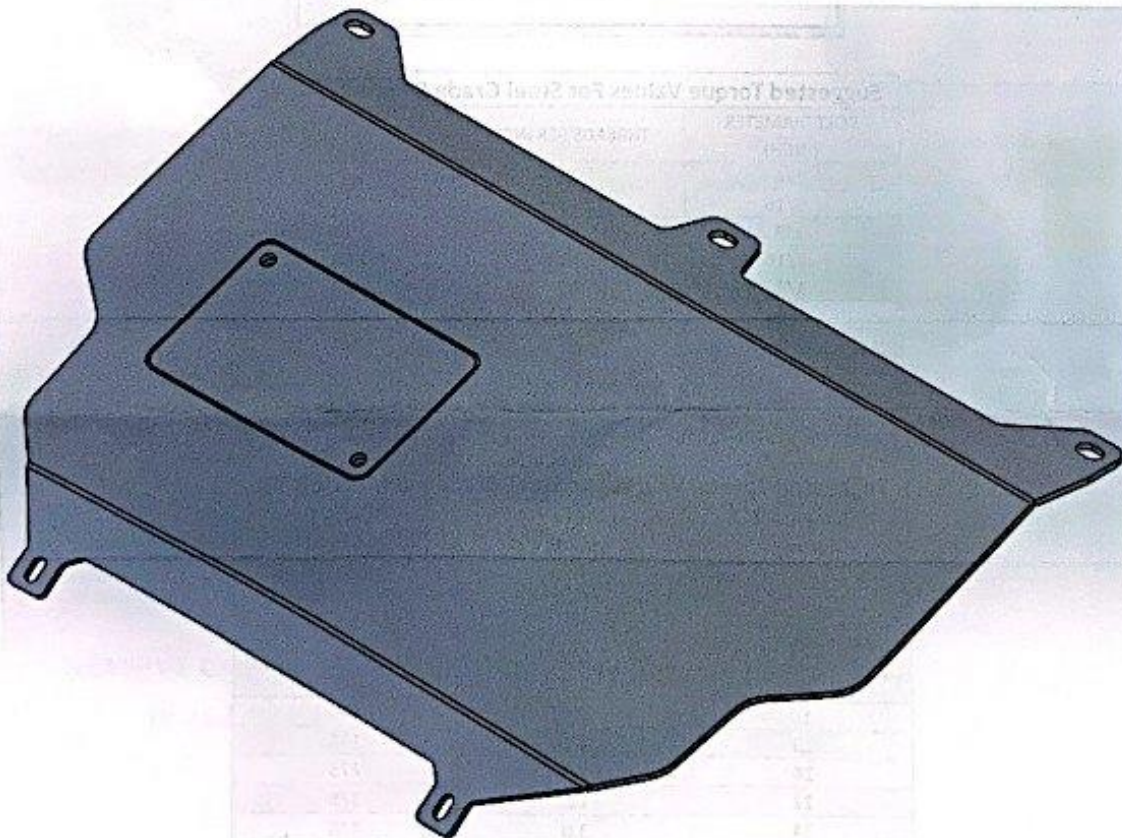

2005-2015 NISSAN XTERRA
SKID PLATE
INSTALLATION INSTRUCTIONS



SAFETY

- **READ ALL SAFETY INSTRUCTIONS BEFORE INSTALLATION**
 - FOLLOW ALL INSTRUCTIONS FOR PROPER ASSEMBLY
 - WEAR APPROPRIATE EYE PROTECTION
 - EXERCISE CARE WHEN LIFTING COMPONENTS
 - USE APPROPRIATE TORQUE FOR BOLTS
 - BLUE THREAD LOCKING COMPOUND IS RECOMMENDED ON ALL BOLTS



**WARNING: Cancer
and Reproductive Harm**

www.P65Warnings.ca.gov



Suggested Torque Values For Steel Grade 5 Standard Bolts

BOLT DIAMETER (INCH)	THREADS PER INCH	TORQUE (POUND - FEET)
1/4	20	7
5/16	18	14
3/8	16	25
7/16	14	40
1/2	13	60
9/16	12	88
5/8	11	120
3/4	10	200
7/8	9	302
1	8	466



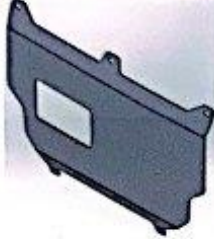

Suggested Torque Values For Steel Grade 8.8 Metric Bolts

BOLT DIAMETER (mm)	THREAD PITCH (mm)	TORQUE (POUND- FEET)
6	1.0	7
8	1.25	16
10	1.5	32
12	1.75	55
14	2.0	88
16	2.0	140
18	2.5	195
20	2.5	275
22	2.5	375
24	3.0	475

I. PARTS LIST

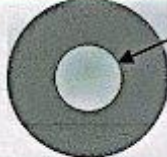
ITEM 1	SKID PLATE	QTY. 1	ITEM 2	COVER	QTY. 1
					

II. HARDWARE KIT #212 (60K-56-0212)

ITEM A	3/8"-16 TORX BOLT	QTY. 3	ITEM B	7/16" FLAT WASHER	QTY. 3
	 T40 TORX BIT			 7/16"	
ITEM C	3/8"-16 NYLOCK NUT	QTY. 3	ITEM D	M6-1.00 TORX BOLT	QTY. 4
				 T30 TORX BIT	
ITEM E	1/4" FLAT WASHER	QTY. 2			
	 1/4"				

**REMOVE CONTENTS FROM BOX AND VERIFY ALL PARTS ARE PRESENT.
IF ALL PARTS ARE NOT PRESENT, CONTACT YOUR DEALER.**

III. TOOL LIST

1. 2 People Required
2. T30 Torx bit
3. T40 Torx bit
4. Torx bit driver
5. 3/8" Socket and Ratchet or Wrench

IV. VEHICLE PREPARATION

1. Park vehicle on level surface.
2. Engage parking brake and disconnect battery.
3. Detach any existing skid plate from vehicle (if applicable).

V. PREPARATION AND INSTALLATION OF NISMO SKID PLATE

1. Lay NISMO Skid plate (ITEM 1) and cover (ITEM 2) face down on a carpet or cardboard surface.



- Using a T40 TORX bit and 3/8" wrench, install the skid plate (ITEM 1) to the NISMO bumper using (3) 3/8"-16 TORX Bolts (ITEM A), (3) 7/16" flat washers (ITEM B), and (3) 3/8"-16 Nylock Nuts (ITEM C) found in hardware kit #212 (60K-56-0212). Location of installation is provided by the callout below. Do not fully tighten.

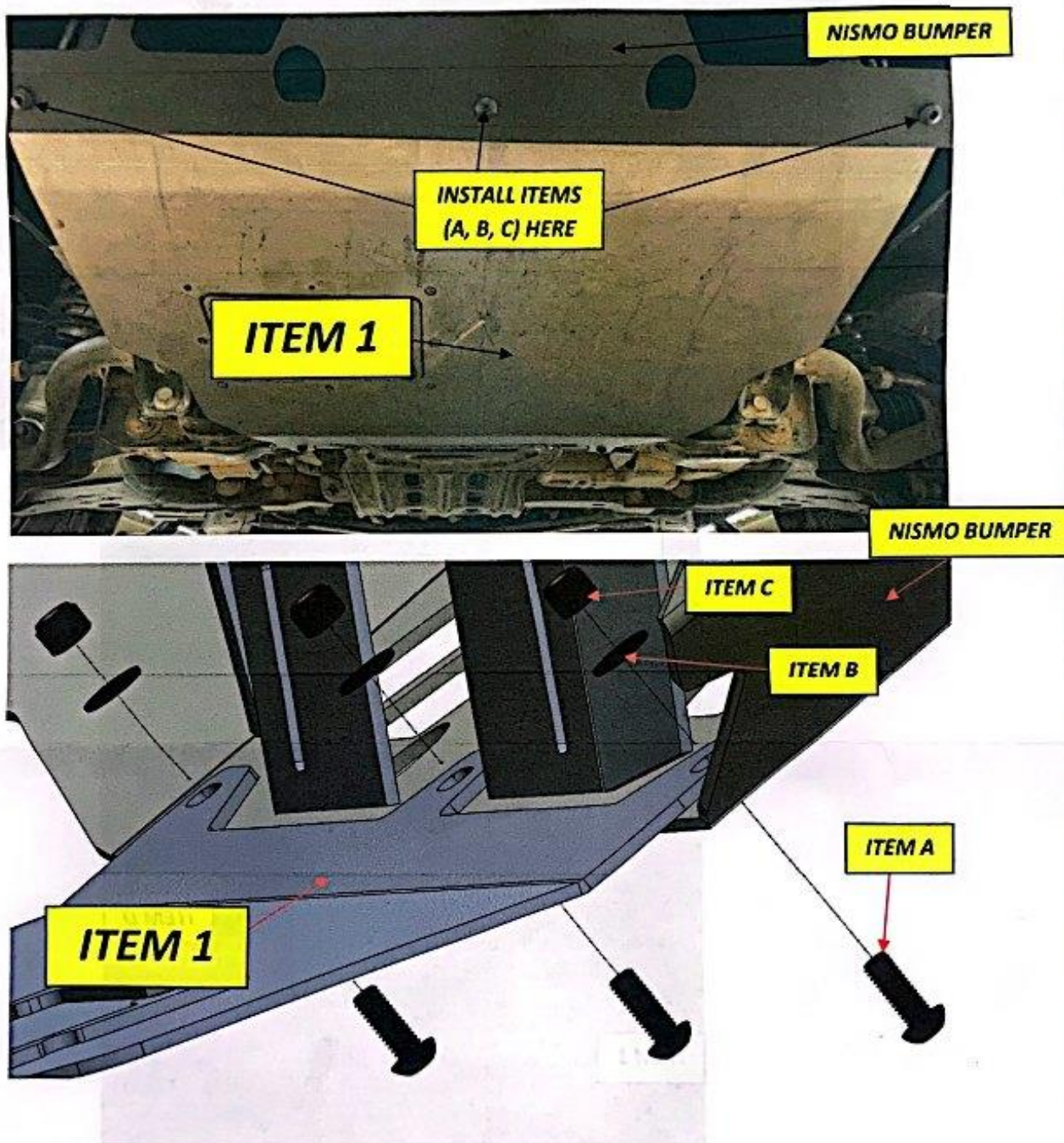

- Using a T30 TORX bit, install the cover (ITEM 2) to the skid plate (ITEM 1) by using (2) M6-1.00 TORX bolts (ITEM D) found in hardware kit #212 (60K-56-0212) as shown below. Fully tighten Cover to skid plate at this time.

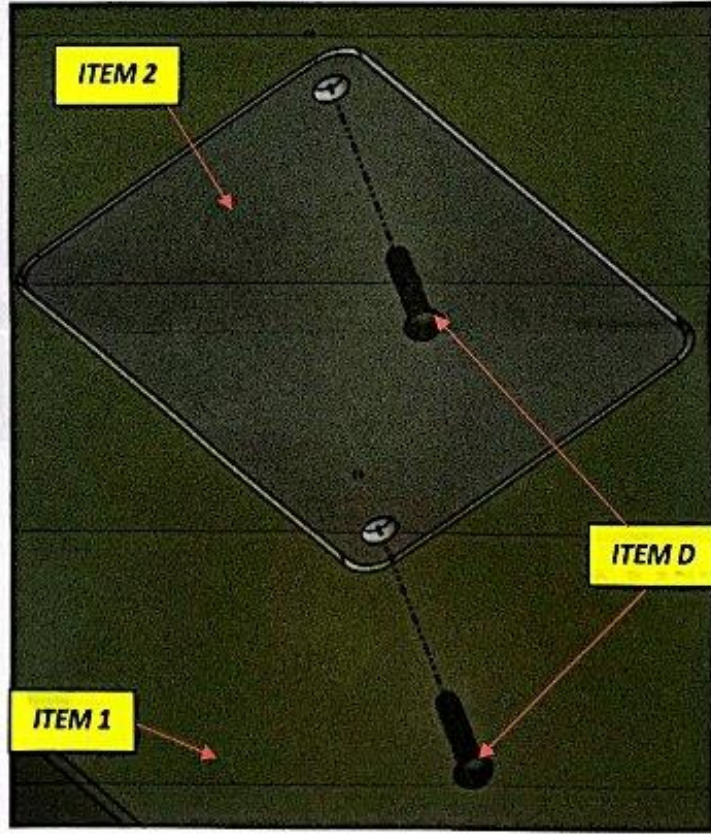

4. Using a T30 Torx bit, fasten the skid plate to the cross member of the frame using (2) 1/4" flat washers (ITEM E) and (2) M6 - 1.00 (ITEM D) torx bolts found in hardware kit #212 (60K-56-0212) as shown below (1 per side). Fully tighten all hardware at this time.

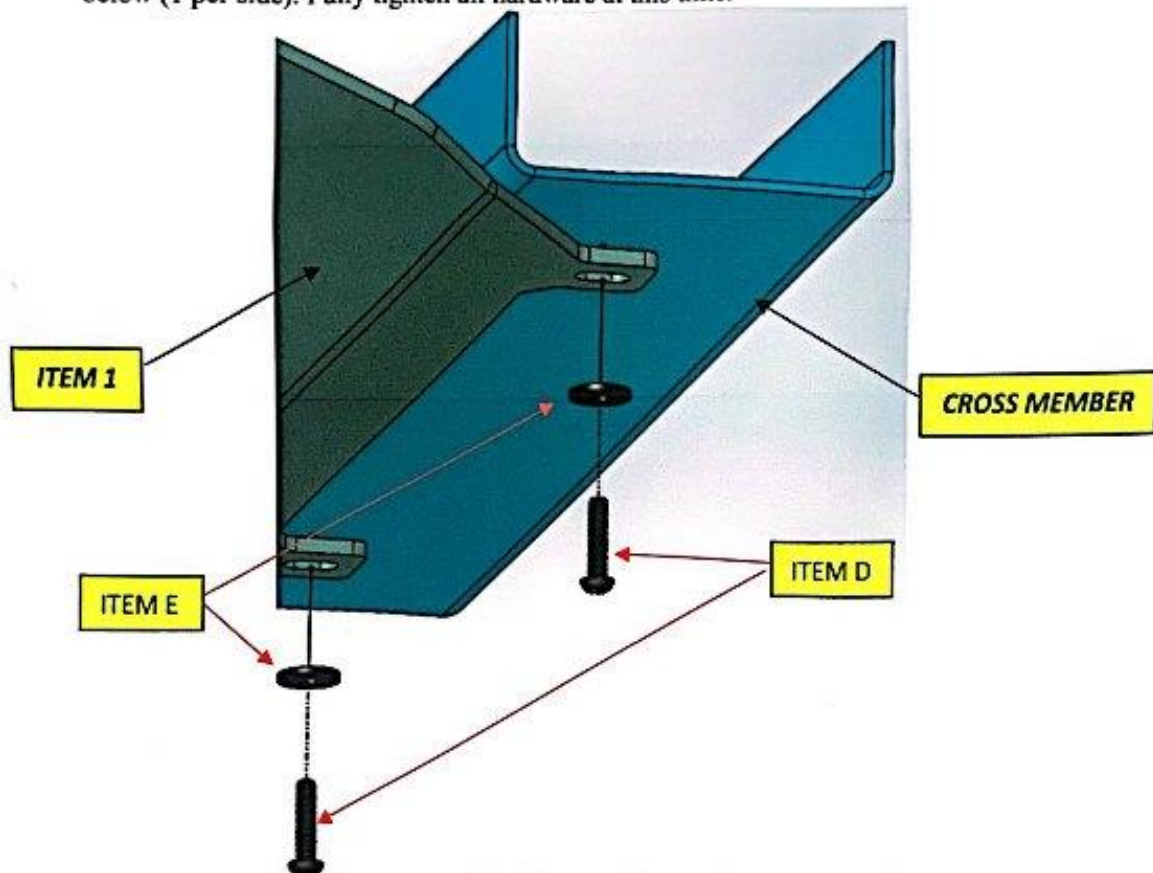

Congratulations! Your Installation is now complete.

Thank You for your purchase!