

Z1 OFF-ROAD ARMADA AND TITAN DITCH LIGHT BRACKETS INSTALLATION MANUAL



This Installation Manual is intended for the following models:	
2004-2015	(A60) Nissan Titan
2004-2015	(TA60) Nissan Armada

PROLOGUE:

Study these instructions completely before proceeding to assembly. The installer must have a thorough knowledge of automotive systems operation, safety, and sound maintenance practices. If unfamiliar with any of the concepts outlined in this instruction, we recommend the installation be completed by a qualified professional.

WARNING!

Extreme caution should be taken when performing maintenance or performance upgrades to your vehicle. Please observe and abide by any Warning or Caution labels placed on the various components and tools used when servicing your vehicle. If you have any questions regarding installation or the various components included with the Z1 Off-Road Ditch Light Brackets, consult with a Professional Mechanic, or contact Z1 Motorsports for more information.

PARTS INCLUDED:

Item	Quantity	Description
1	1	Ditch Light Bracket, LH
2	1	Ditch Light Bracket, RH

TOOLS REQUIRED:

- Ratchet
- Ratchet Extensions
- Assorted Metric Sockets

SAFETY REQUIREMENTS:

- Always wear safety glasses and any necessary protective garments. If using any fluids, chemicals, or solvents, a respirator is recommended.
- Remove jewelry.
- Always use properly rated jack stands when working under your vehicle.
- Always keep limbs and parts away from moving drivetrain parts.
- Always turn the ignition to the OFF position and disconnect the **NEGATIVE** battery terminal.
- Only operate drivetrain in safe space and well-ventilated areas.

BEFORE YOU BEGIN:

Remove contents from the Z1 Off-Road Ditch Light Bracket packaging and verify that **ALL** necessary parts are present.

PROCEDURE:

1. Place the transmission in Park position and apply the parking brake.
2. Open the hood and check hood struts for security. If hood struts do not hold, secure with a prop, or have a partner hold the hood.
3. Identify the Left Hand (LH) bracket by referencing *Figure 1* below.

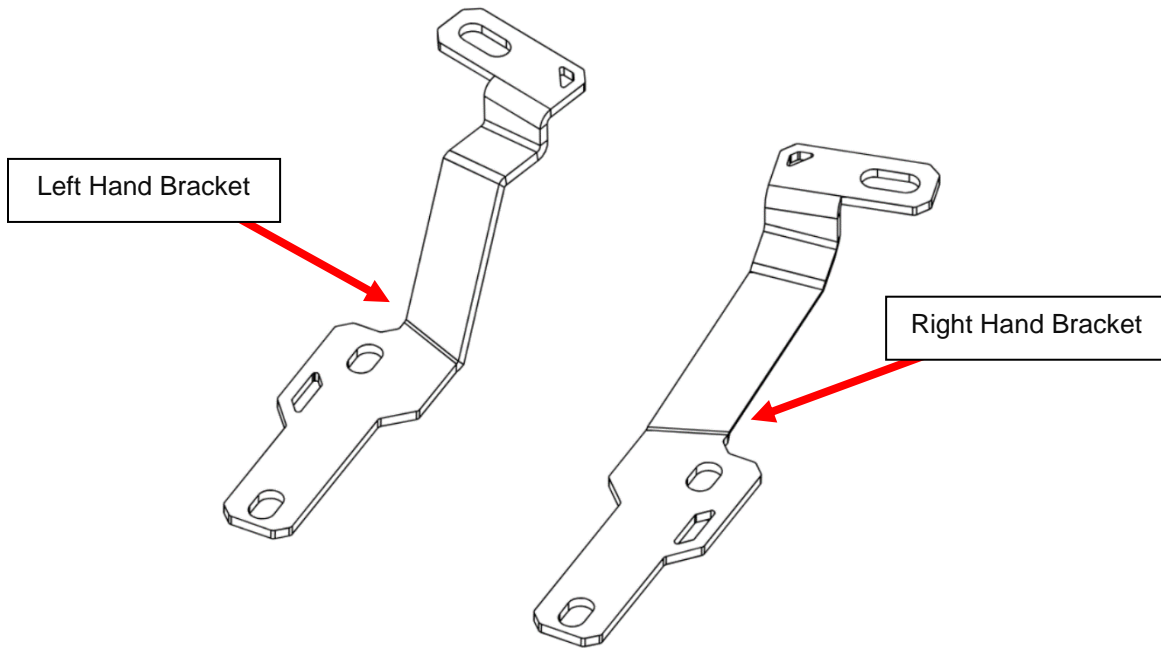

Figure 1

WARNING: Once nuts are removed from the hinge in the next Steps, the hood can slowly flip forward. It is recommended to hold the hood by hand during installation or have a partner hold it until ditch light bracket is installed.

4. Starting with the LH Hinge (Driver Side) and with the Ditch Light Bracket within reach, loosen and remove the (2) two Hood-to-Hinge nuts. *Figure 2*.



Figure 2

5. While keeping the hood secure against the hinge, install the LH ditch light bracket and loosely install the (2) two previously removed nuts.

NOTE: The mounting holes for the ditch brackets are elongated for adjustment. We recommend moving the ditch light bracket fully forward to avoid scratching the cowl panel. If you're concerned about scratching the cowl panel, we recommend using a rag or painters tape on the cowl prior to closing the hood.

6. Close the hood to verify clearance between the bracket and cowl panel. *Figure 3.*



Figure 3

7. Once fitment is confirmed, open the hood, and tighten the (2) two Hood-to-Hinge nuts.
8. Repeat *Steps 3-7* for Right Hand (RH) bracket.
9. Account for and remove tools.
10. Install desired Ditch Lights. Follow manufacturer instructions for proper installation.

END

Additional Technical Support:
Contact Z1 Off-Road at info@z1offroad.com
Or call 678-839-8019 between 9am and 6pm ET