

# Z1 D41 FRONTIER ASSAULT FRONT BUMPER INSTALLATION MANUAL

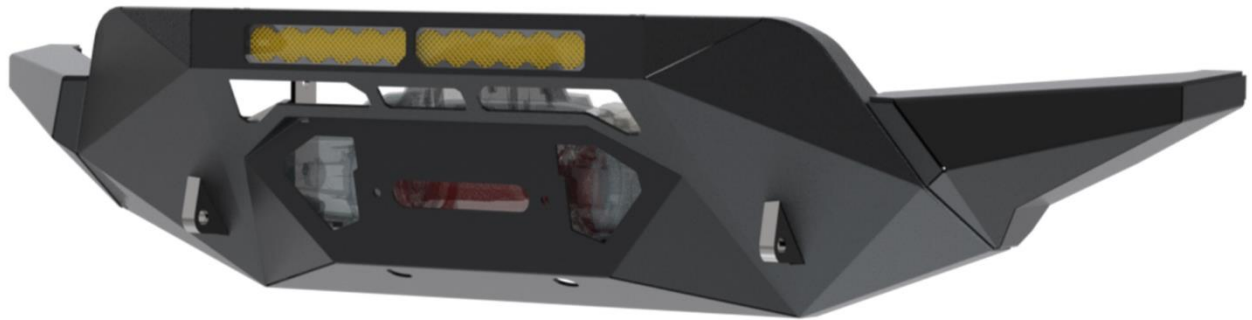

This Installation Manual is intended for the following models:

2022+

Nissan Frontier (D41)

## PROLOGUE:

Study these instructions completely before proceeding to assembly. The installer must have a thorough knowledge of automotive systems operation. If unfamiliar with any of the concepts outlined in this instruction, we recommend the installation be completed by a qualified professional.

## WARNING!

Extreme caution should be taken when performing maintenance or performance upgrades to your vehicle. Please observe and abide by any Warning or Caution labels placed on the various components and tools used when servicing your vehicle. If you have any questions regarding installation or the various components included with the Z1 Off-Road D41 Frontier Front Bumper, consult with a Professional Mechanic, or contact Z1 Off-Road for more information.

## **PARTS INCLUDED:**

Item	Quantity	Description
1	1	Main Bumper
2	1	RH Lower Support
3	1	LH Lower Support
4	1	RH Adjustable Mount
5	1	LH Adjustable Mount
6	4	M16 x 2.0 Nyloc Nut
7	4	M16 x 2.0 Hex Bolt, 50mm
8	10	M12 x 1.25 Hex Bolt, 35mm
9	4	M12 x 1.25 Hex Bolt, 45mm
10	8	M16 Oversized Washer
11	10	M12 Oversized Washer
<b>D41 Sonar Relocation Kit</b>		
12	1	Base Bracket
13	1	Sensor Mounting Plate
14	3	M8 x 1.25 Button Head Screw, 20mm
15	3	M8 x 1.25 Nyloc Nut
<b>Bumper Wings</b>		
16	1	Left Side Wing
17	1	Right Side Wing
18	8	M10 x 1.25 Nyloc Nut
19	8	M10 x 1.25 Flange Bolt, 25mm

## **TOOLS REQUIRED:**

- Hydraulic Jack
- (2) 2-Ton (or greater) Jack Stands
- Ratchet
- Ratchet Extension(s)
- Assorted Metric Sockets
- Assorted Metric Wrenches
- Torque Wrench
- Airsaw, Cutting Wheel
- 1" Painters Tape
- Screwdrivers

## **SAFETY REQUIREMENTS:**

- Always wear safety glasses and any necessary protective garments. If using any fluids, chemicals, or solvents, a respirator is recommended.
- Always use properly rated jack stands when working under your vehicle.
- Always keep limbs and parts away from moving drivetrain parts.
- Always turn the ignition to the OFF position and disconnect the NEGATIVE battery terminal.
- Only operate drivetrain in safe space and well-ventilated areas.

## **BEFORE YOU BEGIN:**

Remove contents from the Z1 Off-Road D41 Frontier Front Bumper and verify that ALL necessary hardware is present.

Some Steps of this Installation will be significantly easier with the help of at least one other person.

## **PROCEDURE:**

1. Place the transmission in Park position (or in Reverse gear if equipped with a manual transmission). Apply the parking brake.

**NOTE:** Steps 2-4 are optional. This installation can be done on the ground but will be easier if the truck is raised and the front wheels are removed.

2. Loosen lug nuts on front wheels.
3. Raise and support the truck using a jack and jack stands.
4. Remove the front wheels from the truck.
5. Remove the Front Mud Guards, they are held on by (3) three screws each. Retain this hardware. *Figure 1.*



*Figure 1*

6. Remove the Front Fender Liners. These are held on by an assortment of plastic pins and (2) two screws behind the lip of the Fender Flare. Retain this Hardware. *Figure 2* shows some of the mounting points.



*Figure 2*

7. Remove the Front Fender Flares if applicable. These are held on by multiple clips inside of the wheel well. Using a pair of pliers, pinch the clips from inside the wheel well while slightly pulling the Fender Flare. Work from one side of the Fender Flare to the other to remove it from the body. The mounting points are shown below. *Figure 3*.



*Figure 3*

8. Remove the cover on top of the Radiator, it is held on by (6) six plastic tabs. Retain this hardware. *Figure 4.*

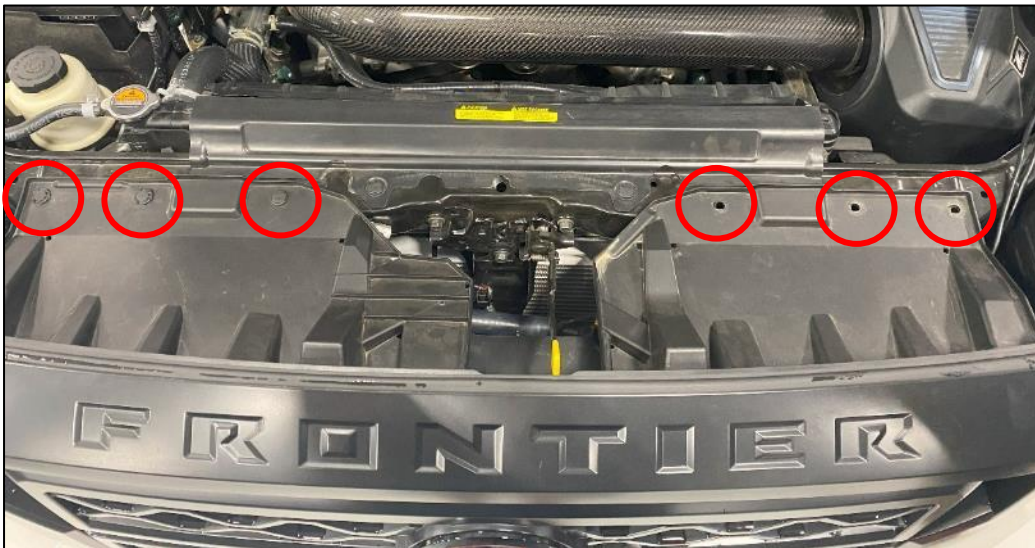

*Figure 4*

9. Remove the (2) two bolts holding the Front Grille to the Core Support. After the bolts are removed, the Grille can be pulled off, it is held on by plastic clips. *Figure 5.*



*Figure 5*

10. Disconnect the Fog Light harness on each side of the vehicle.
11. Remove the Front Bumper. (1) One Screw on each side of the Wheel Well holds it on, as well as some plastic clips. After removing the screws, pull the bumper away from each side of the truck. After the sides have been unclipped, pull the bumper forward off the car. It is recommended to do this with at least one other person. *Figure 6.*



*Figure 6*

12. Remove the Foam Impact Absorber from the Front Crash Bar. *Figure 7.*



*Figure 7*

13. Disconnect the Radar Sensor and remove the (3) three bolts securing it to the Front Crash Bar. Set the Radar Sensor aside in a safe place and retain the mounting hardware. *Figure 8.*

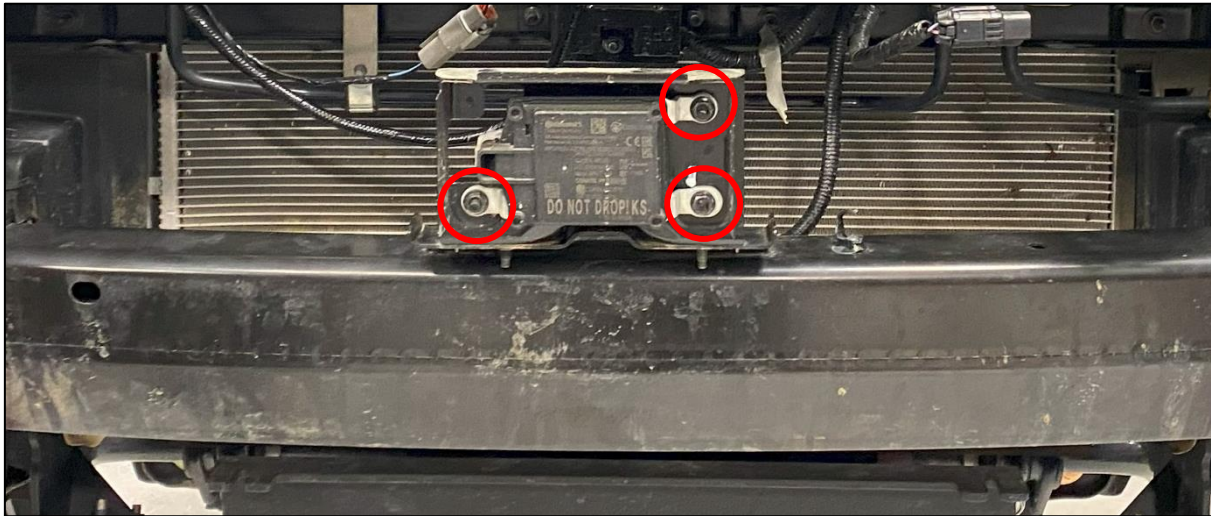

*Figure 8*

14. Remove the Front Crash Bar, it is held on by (4) four bolts, two on each side. *Figure 9.*



*Figure 9*



15. Remove the Front Tow Hooks, held on by (2) two bolts each. *Figure 10.*

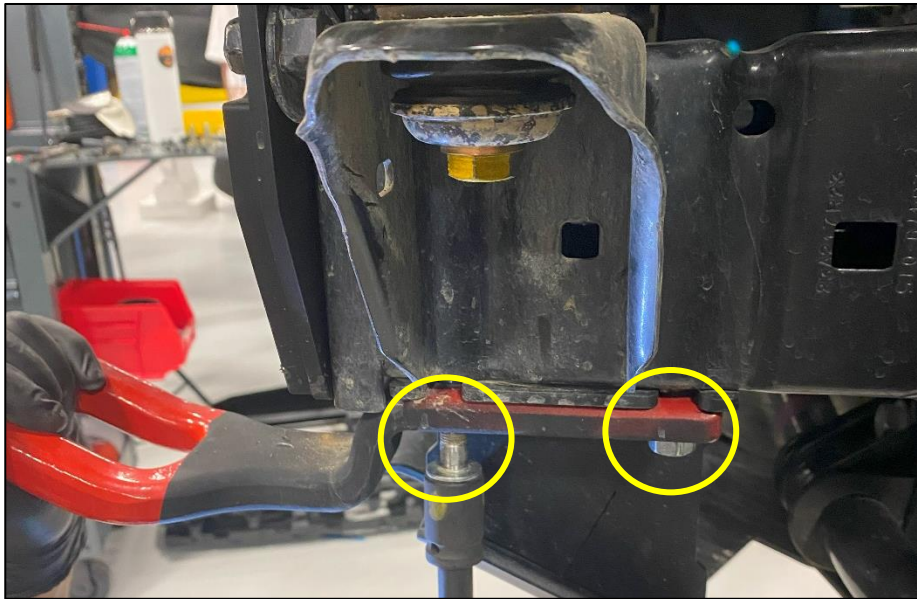

*Figure 10*

16. If applicable, remove equipped Skid Plate.

17. Trim the Passenger Side Radiator Air Guide as shown below. *Figure 11.*

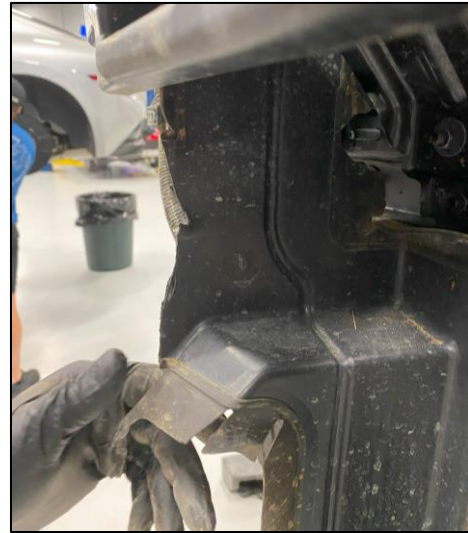
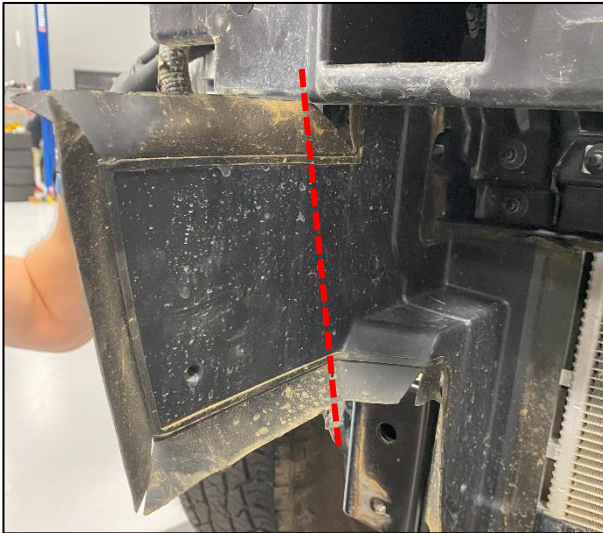

*Figure 11*

18. Remove the Driver Side Radiator Air Guide.

19. Clean the Front Crash Bar mounting surface of any debris. *Figure 12.*



*Figure 12*

20. Locate the RH Lower Support, LH Lower Support, (4) four M12 x 1.25 Hex Bolts, 35mm, and (4) four M12 Washers. Position the Lower Supports on the OE Tow Hook mounts as shown below, and loosely secure them with the M12 Bolts and Washers. *Figure 13.*

**NOTE:** If you are using a Skid Plate, use the (4) four 45mm M12 x 1.25 Hex Bolts instead of the 35mm M12 x 1.25 Bolts. The 35mm bolts will not have enough thread engagement with a Skid Plate.

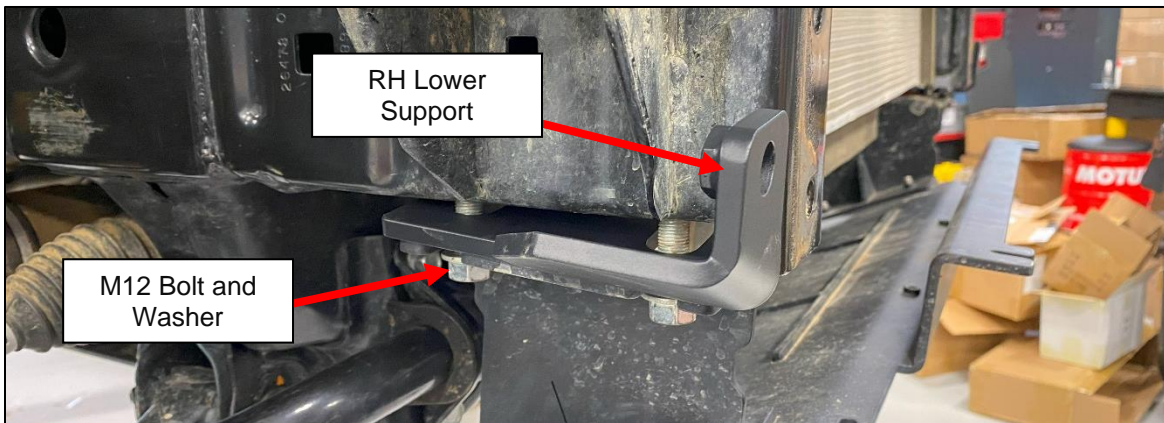

*Figure 13*

21. Locate the RH Adjustable Mount, LH Adjustable Mount, (6) six M12 x 1.25 Hex Bolts, 35mm, and (6) six M12 Washers. Position the Adjustable Mounts on the OE Front Crash Bar Mount, and sandwich the lower tab between the Lower Supports installed in *Step 20*, and the Frame Rail. Loosely secure each mount with (3) three M12 Bolts and Washers. *Figure 14*.

**NOTE:** If you are using a Skid Plate, this can be installed now.

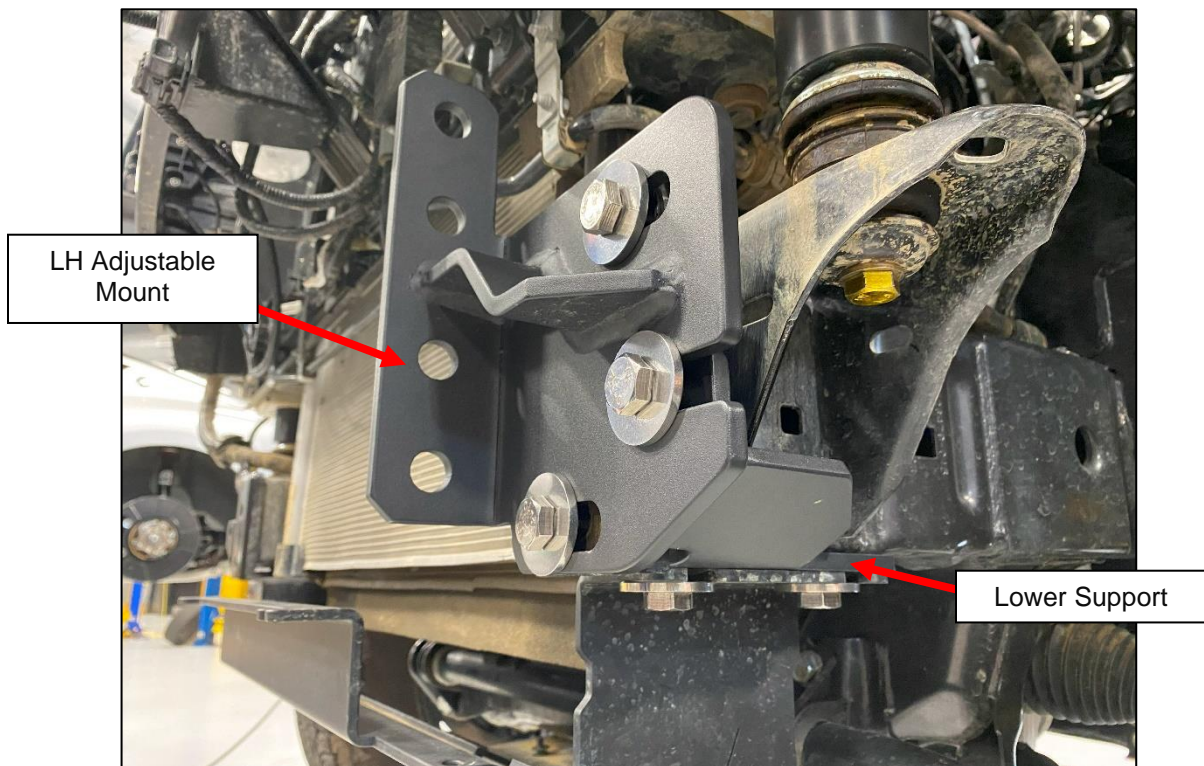
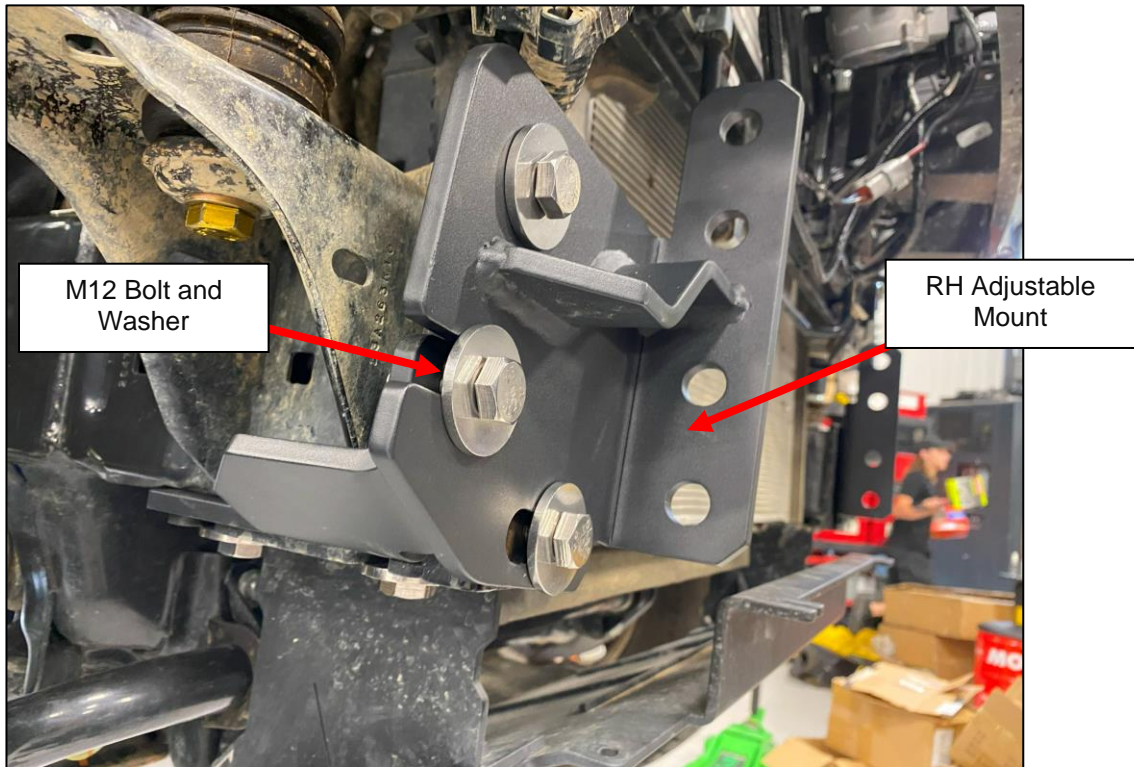

*Figure 14*

22. Locate the Main Bumper, (4) four M16 x 2.0 Bolts, (4) four M16 x 2.0 Nyloc Nuts, and (8) eight M16 Washers. With the help of at least one other person, raise the Main Bumper to the front of the truck. Position it so that the mounting tabs are on the outside of the Adjustable Mounts. Loosely secure the bumper with the M16 Hardware, with a Washer on each side. *Figure 15.*

**NOTE:** There are two different mounting points to use for the bumper, depending on if you have a body lift or not. We used the higher of the mounting points as our truck has a body lift.

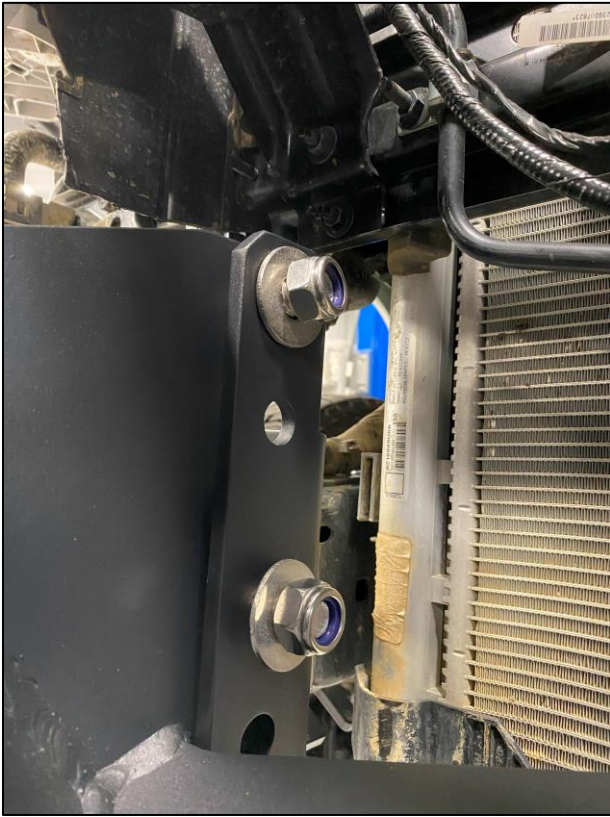

*Figure 15*

23. Locate your OE Front Bumper. Trim the inside section out using an Airsaw or equivalent tool. *Figure 16.*



*Figure 16*

24. Test fit the OE Front Bumper over the new Z1 Front Bumper and clean up any rough edges if necessary.  
*Figure 17.*



*Figure 17*

25. Position the Z1 Front Bumper as necessary, checking for uneven gaps between it and the OE Front Bumper. Once positioned as desired, tighten all bolts on the Mounting Plates to Frame and Mounting Plates to Front Bumper. Torque the M12 bolts to **65 ft-lbs** and the M16 Bolts to **156 ft-lbs.**
26. While on the vehicle, use 1" Painters tape, mark the front bumper, following the body line of the Fog Lights.  
*Figure 18 and Figure 19.*



*Figure 18*



Figure 19

27. Remove the OE Front Bumper from the vehicle.

28. Remove the Fog Lights from the Front Bumper, each light is held on by (3) three screws. Figure 20.

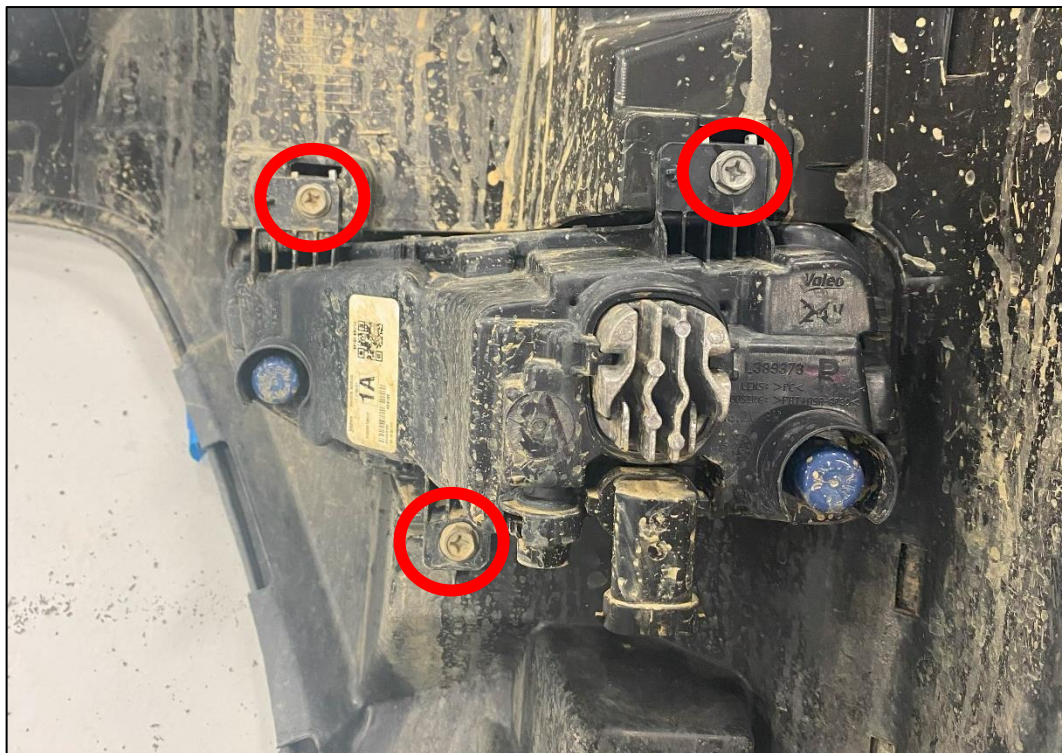

Figure 20

29. Install the Bumper Wings onto the Z1 Front Bumper. Each Bumper Wing is held on by (4) four M10 Bolts and (4) four M10 Washers. Torque the bolts to **38 ft-lbs.** *Figure 21.*



*Figure 21*

30. Carefully Trim below the line marked with tape on the Front Bumper. We recommend spacing about 1/2" from the taped line to give room to trim more if necessary. You can always cut more but can't add back to the bumper. If your truck is equipped with Fender Flares, these will also need to be trimmed. *Figure 22.*

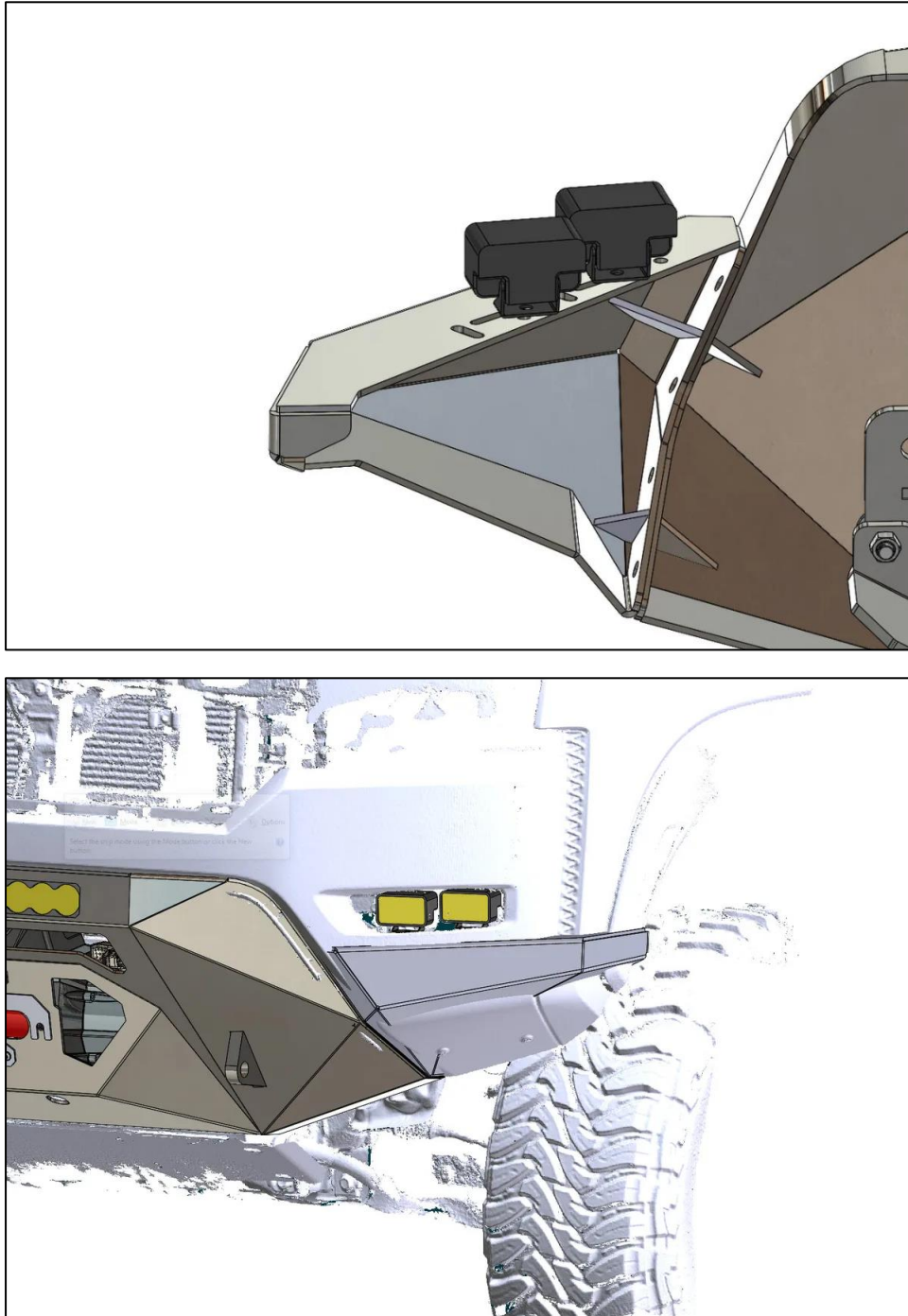

*Figure 22*

31. Test fit the OE Front Bumper over the Bumper Wings, trim the bumper to fit as necessary.

32. Once satisfied with fitment of the OE Front Bumper, reinstall the OE Fog Lights.

**NOTE:** The Bumper Wings have slots to mount Aftermarket Lights in place of the OE Fog Lights if desired. Follow Manufacturer Instructions for wiring and installation if you choose to replace the OE Fog Lights.  
*Figure 23.*



*Figure 23*



33. Reinstall the OE Front Bumper on the truck with the factory hardware and clips. *Figure 24.*

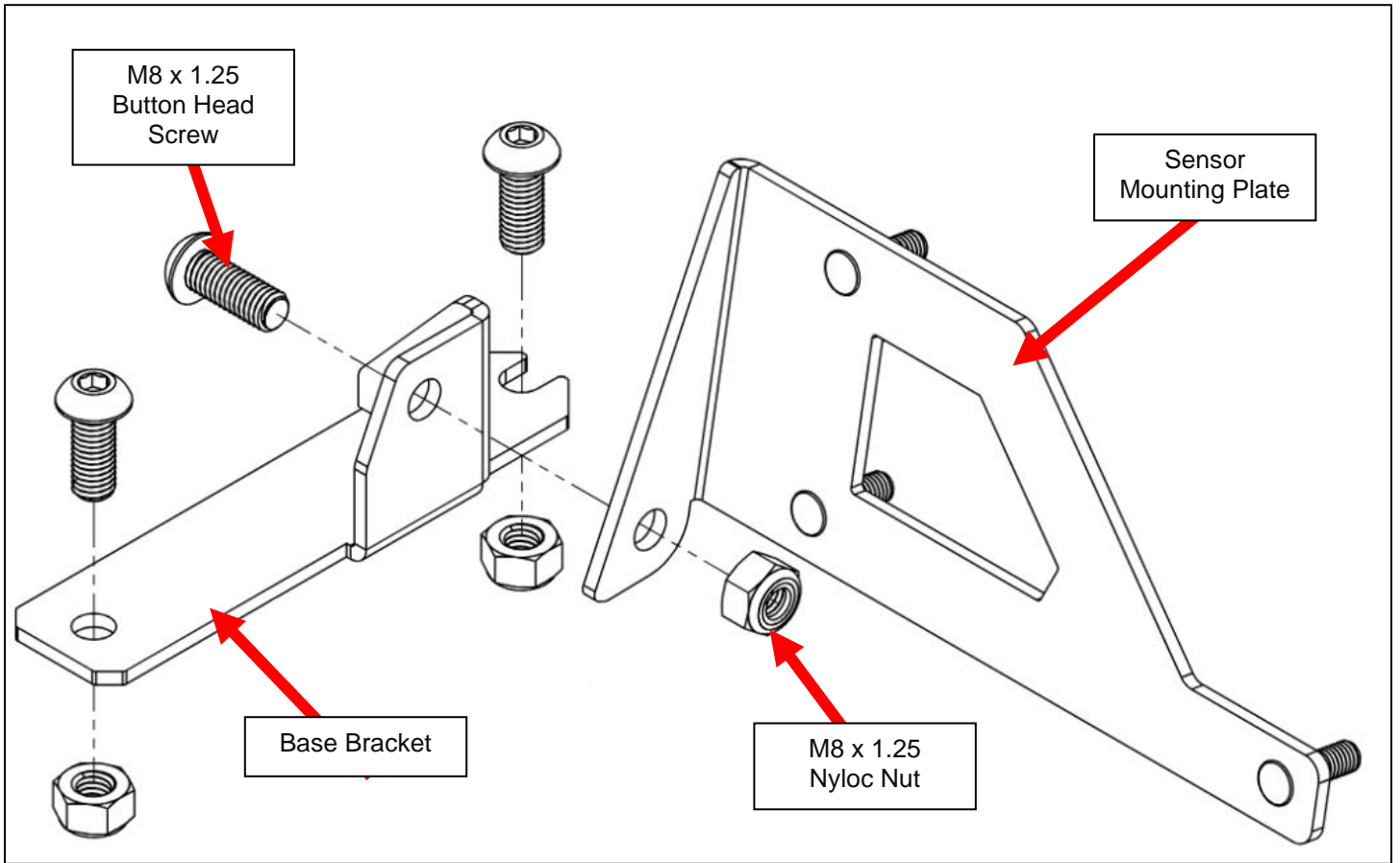

*Figure 24*

**NOTE:** Steps 34-37 are for using the Radar Relocation Bracket for the Radar sensor disconnected in Step 13.

34. Locate the Radar Relocation Base Bracket, Sensor Mounting Plate, (3) three M8 x 1.25 Button Head Screws, and (3) three M8 x 1.25 Nyloc Nuts. Mount the Radar Sensor to the Sensor Mounting Plate with the OE Hardware removed in Step 13.

35. Bolt the Sensor Mounting Plate to the Base Bracket with (1) one M8 x 1.25 Button Head Screw, and (1) one M8 x 1.25 Nyloc Nut. *Figure 25.*



*Figure 25*

36. Mount the Radar Relocation Assembly to one of the mounting brackets behind the Front Grille using (2) two M8 x 1.25 Button Head Screws and (2) two M8 x 1.25 Nyloc Nuts. *Figure 26.*



*Figure 26*

37. Reconnect the Radar Sensor Wiring Harness to the Radar Sensor.
38. Follow *Steps 5-9* in reverse order to reinstall the Front Grille and other bumper accessories.
39. Reinstall front wheels and lug nuts.
40. Safely lower vehicle off jackstands.

**END**

**Additional Technical Support:**  
Contact Z1 Off-Road at [info@z1offroad.com](mailto:info@z1offroad.com)  
Or call 678-839-8019 between 9am and 6pm ET