

# Z1 D41 FRONTIER RADAR RELOCATION BRACKET INSTALLATION MANUAL



This Installation Manual is intended for the following models:

2022+

Nissan Frontier (D41)

## PROLOGUE:

Study these instructions completely before proceeding to assembly. The installer must have a thorough knowledge of automotive systems operation. If unfamiliar with any of the concepts outlined in this instruction, we recommend the installation be completed by a qualified professional.

## WARNING!

Extreme caution should be taken when performing maintenance or performance upgrades to your vehicle. Please observe and abide by any Warning or Caution labels placed on the various components and tools used when servicing your vehicle. If you have any questions regarding installation or the various components included with the Z1 Motorsports D41 Frontier Radar Relocation Kit, consult with a Professional Mechanic, or contact Z1 Motorsports for more information.

## **PARTS INCLUDED:**

Item	Quantity	Description
1	1	Base Bracket
2	1	Sensor Mounting Plate
3	3	M8 x 1.25 Button Head Hex Screw, 20mm
4	3	M8 x 1.25 Locknut

## **TOOLS REQUIRED:**

- Ratchet
- Ratchet Extension(s)
- Assorted Metric Wrenches
- Assorted Metric Sockets

## **SAFETY REQUIREMENTS:**

- Always wear safety glasses and any necessary protective garments. If using any fluids, chemicals, or solvents, a respirator is recommended.
- Always turn the ignition to the OFF position and disconnect the NEGATIVE battery terminal.
- Always use properly rated jack stands when working under your vehicle.
- Always keep limbs and parts away from moving drivetrain parts.
- Only operate drivetrain in safe space and well-ventilated areas.

## **BEFORE YOU BEGIN:**

Remove contents from the Z1 Motorsports D41 Radar Relocation Kit and verify that ALL necessary hardware is present.

This product assumes you already have an aftermarket bumper installed and have the OEM Radar Sensor removed from the vehicle. Please reference the [D41 Bumper Install Manual](#) for removal of the OEM Radar Sensor and Front Bumper if necessary.

## PROCEDURE:

1. Place the transmission in Park position (or in Reverse gear if equipped with a manual transmission). Apply the parking brake.
2. Open and support the hood of the vehicle.
3. Disconnect the (-) **NEGATIVE** battery terminal.
4. Remove the cover on top of the Radiator, it is held on by (6) six plastic tabs. Retain this hardware. *Figure 1.*

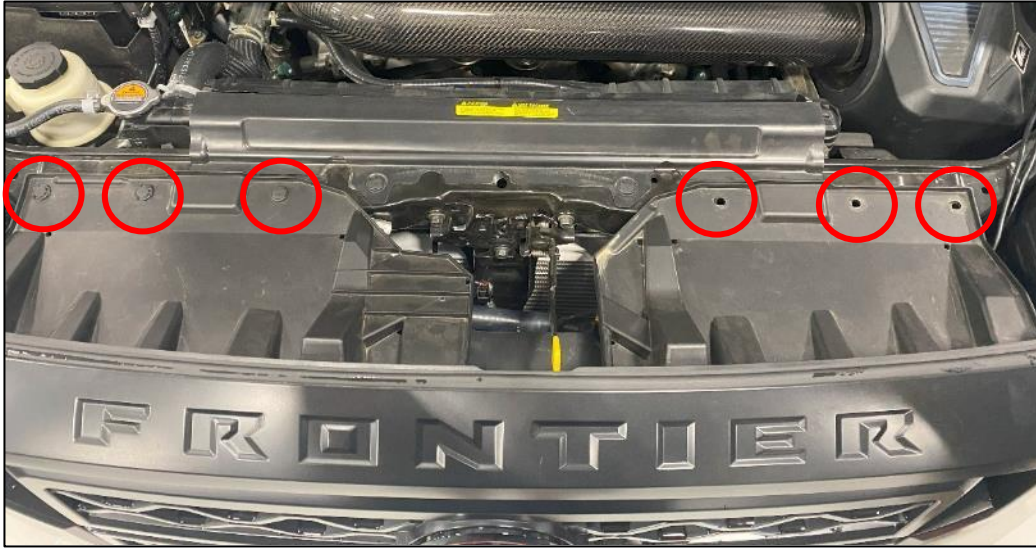

*Figure 1*

- Remove the (2) two bolts holding the Front Grille to the Core Support. After the bolts are removed, the Grille can be pulled off. It is held on by plastic clips. *Figure 2.*



*Figure 2*

- Remove the Radar Sensor from the vehicle if it has not already been done so. Reference the [D41 Bumper Install Manual](#) for instructions on how to remove the OEM Radar Sensor and Front Bumper.
- Locate the Radar Relocation Base Bracket, Sensor Mounting Plate, (3) three M8 x 1.25 Button Head Screws, and (3) three M8 x 1.25 Nyloc Nuts. Mount the Radar Sensor to the Sensor Mounting Plate with the OE Hardware that secures it to the OEM Mounting Plate.

8. Bolt the Sensor Mounting Plate to the Base Bracket with (1) one M8 x 1.25 Button Head screw and (1) one M8 x 1.25 Nyloc Nut. *Figure 3.*

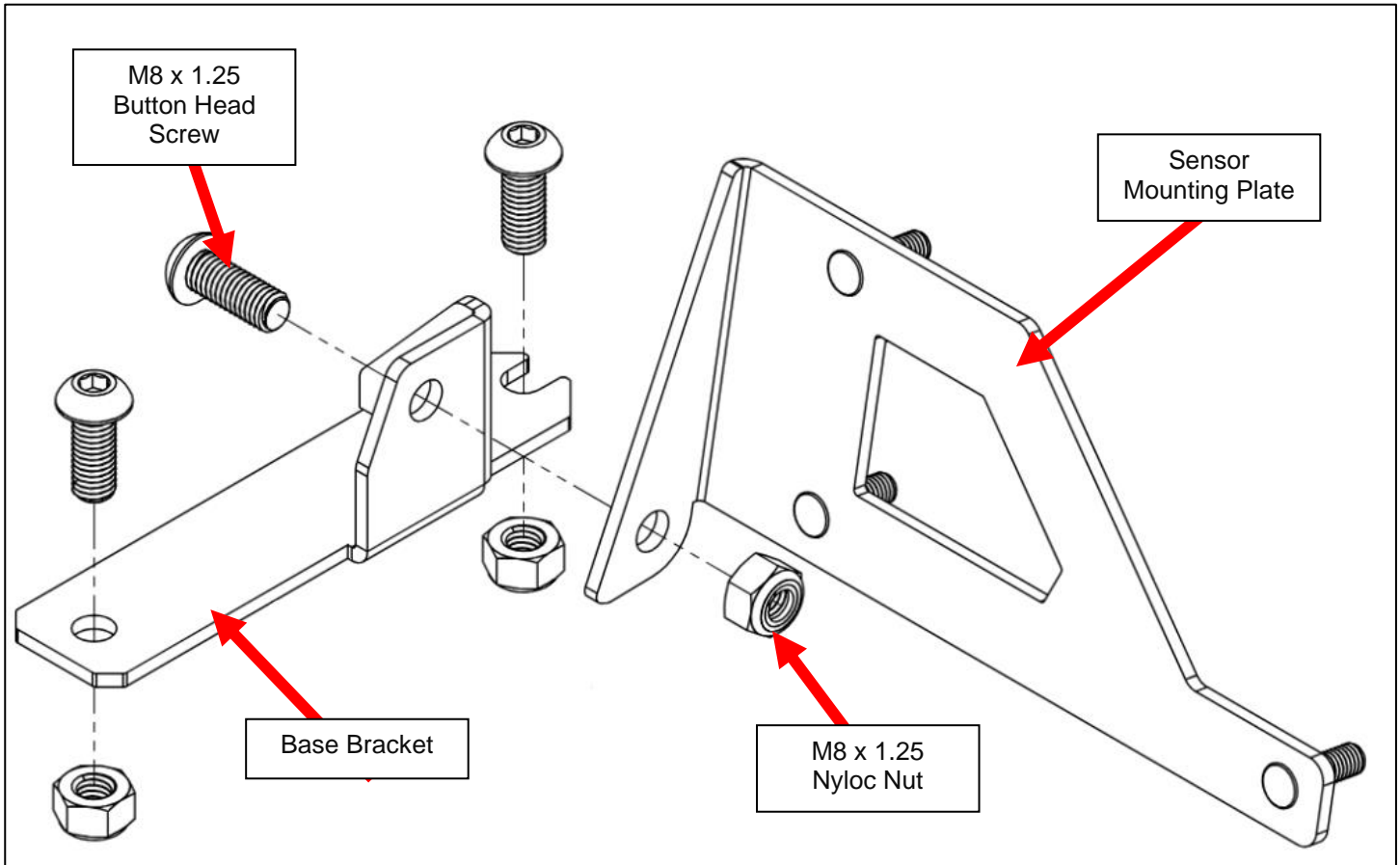

Figure 3

9. Mount the Radar Relocation Assembly to one of the mounting brackets behind the Front Grille using (2) two M8 x 1.25 Button Head Screws and (2) two M8 x 1.25 Nyloc Nuts. *Figure 4.*



*Figure 4*

10. Connect the Radar Sensor Wiring Harness to the Radar Sensor.
11. Follow *Steps 3-6* in reverse to reinstall the Fronte Grille and other bumper accessories.
12. Test function of your Radar Sensor. Recalibration may be necessary.

**END**

**Additional Technical Support:**  
Contact Z1 Off-Road at [info@z1offroad.com](mailto:info@z1offroad.com)  
Or call 678-839-8019 between 9am and 6pm ET