

Z1 NISSAN XTERRA SNORKEL INSTALLATION MANUAL



This Installation Manual is intended for the following models:	
2005-2015	Nissan Xterra

PROLOGUE:

Study these instructions completely before proceeding to assembly. The installer must have a thorough knowledge of automotive systems operation. If unfamiliar with any of the concepts outlined in this instruction, we recommend the installation be completed by a qualified professional.

WARNING!

Extreme caution should be taken when performing maintenance or performance upgrades to your vehicle. Please observe and abide by any Warning or Caution labels placed on the various components and tools used when servicing your vehicle. If you have any questions regarding installation or the various components included with the Z1 Off-Road Nissan Xterra Snorkel, consult with a Professional Mechanic, or contact Z1 Off-Road for more information.

PARTS INCLUDED:

Item	Quantity	Description
1	1	Snorkel Upright
2	1	Snorkel Coupler
3	1	Locating Template
4	1	A-Pillar Bracket
5	1	Fender Pipe
6	1	Snorkel Inlet Head
7	1	Inlet Face
8	1	Drain Plug
9	3	Rubber Grommet
10	4	M6 x 1.0 Flat Head Screw
11	2	M6 x 1.0 Socket Head Screw
12	3	M8 x 1.25 Hex Head Screw
13	3	Washer
14	3	Hose Clamp
15	1	Black Clamp
Z1 Airbox		
16	1	Z1 Airbox Fender Grommet
17	1	Worm-Drive Clamp
Factory Airbox		
18	1	OE Airbox Fender Grommet
19	1	Hose Clamp

TOOLS REQUIRED:

- Hydraulic Jack
- (2) 2-Ton (or greater) Jack Stands
- Ratchet
- Ratchet Extension(s)
- Assorted Metric Sockets
- Assorted Metric Wrenches
- Torque Wrench
- Hammer
- Painters Tape
- RTV Gasket Maker/Super Glue
- Marker
- Drill
- Drill Bits
- Center Punch
- Airsaw/Dremel
- File
- Touch-up Paint
- Trim Removal Tool

SAFETY REQUIREMENTS:

- Always wear safety glasses and any necessary protective garments. If using any fluids, chemicals, or solvents, a respirator is recommended.
- Always use properly rated jack stands when working under your vehicle.
- Always keep limbs and parts away from moving drivetrain parts.
- Always turn the ignition to the OFF position and disconnect the NEGATIVE battery terminal.
- Only operate drivetrain in safe space and well-ventilated areas.

BEFORE YOU BEGIN:

Remove contents from the Z1 Off-Road Nissan Xterra Snorkel and verify that ALL necessary hardware is present.

PROCEDURE:

1. Place the transmission in Park position (or in Reverse gear if equipped with a manual transmission). Apply the parking brake.
2. Open and support hood of vehicle.
3. Locate the Snorkel Upright and (3) three Rubber Grommets. Using RTV Gasket Maker or Super Glue, secure the Rubber Grommets to the Snorkel Upright mounting points. Allow the RTV to cure for around (15) fifteen minutes. *Figure 1.*

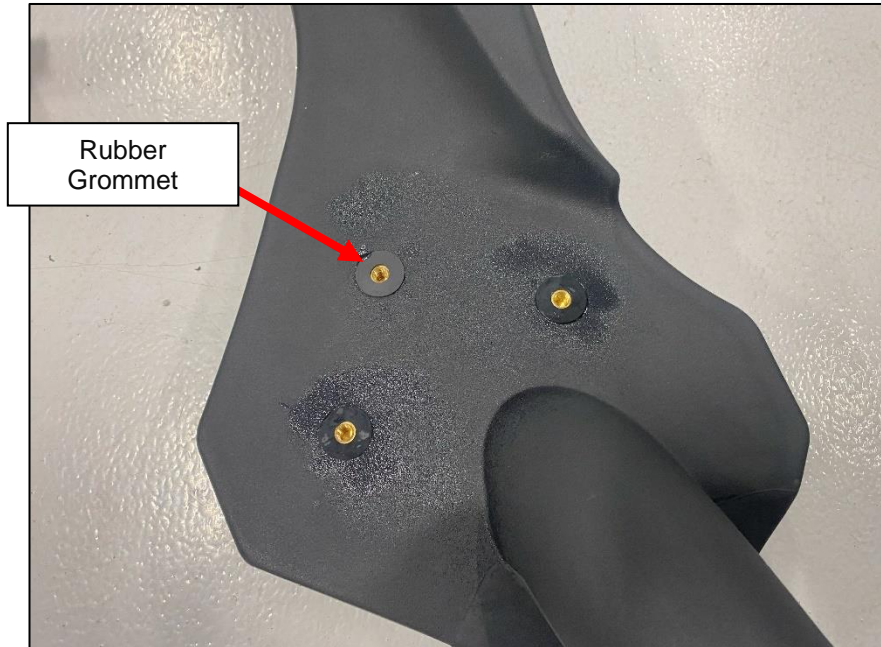

Figure 1

4. Remove your Z1 Intake Tube and Intake Airbox. *Figure 2.*

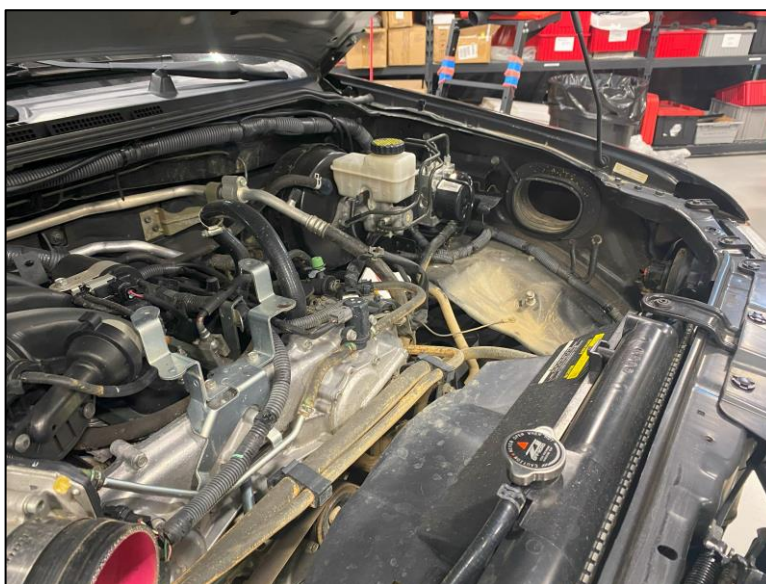

Figure 2

5. Remove the hardware securing the Driver's Side Front Fender Liner and remove the Front Fender Liner from the vehicle. It will be an assortment of clips and screws. *Figure 3.*

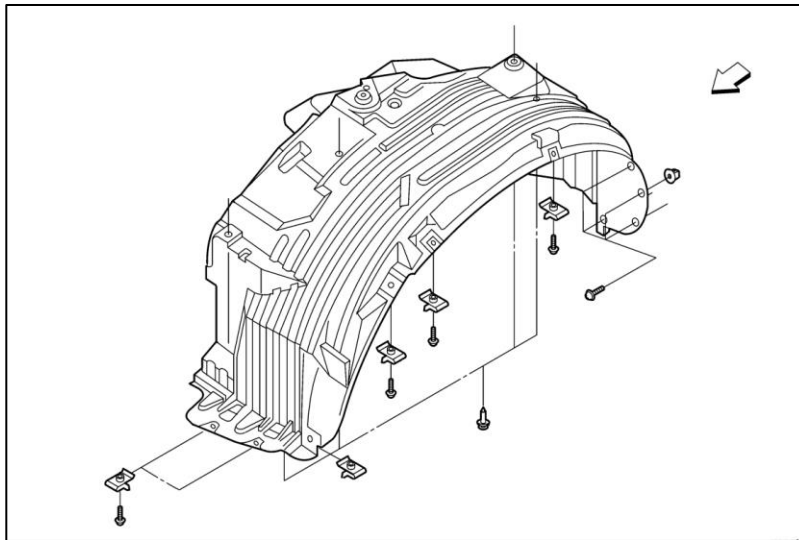

Figure 3

6. Clean and prep the outside of the Driver's Side Fender.
7. Using Painters Tape, tape over the section of the Driver's Side Fender where you will cut. Use enough tape to cover the entire area where the Locating Templates will sit. *Figure 4.*



Figure 4

8. Locate the Locating Template and fit it to the Driver's Side Fender. The Locating Template is form-fitted to the Fender and can only go on one way. You want the gap from the Template-to-Door Gap and Template-to-Hood Gap to be the same. Once positioned, secure with Painters Tape. *Figure 5.*

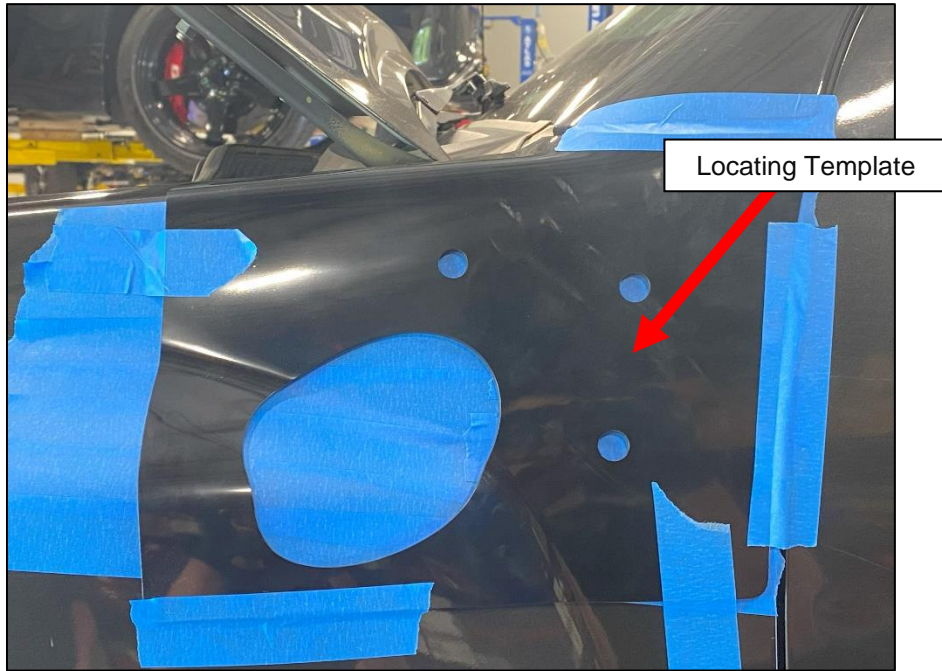

Figure 5

9. Using a marker, trace the inside of the Locating Template Holes. The Locations are marked below. *Figure 6.*

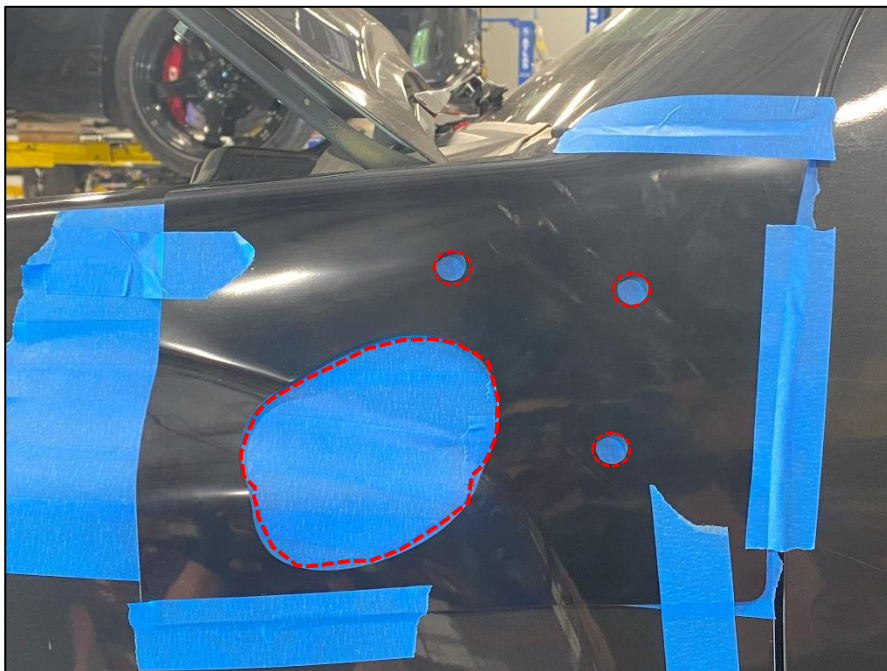

Figure 6

10. Remove the Locating Template, revealing lines to cut. *Figure 7.*

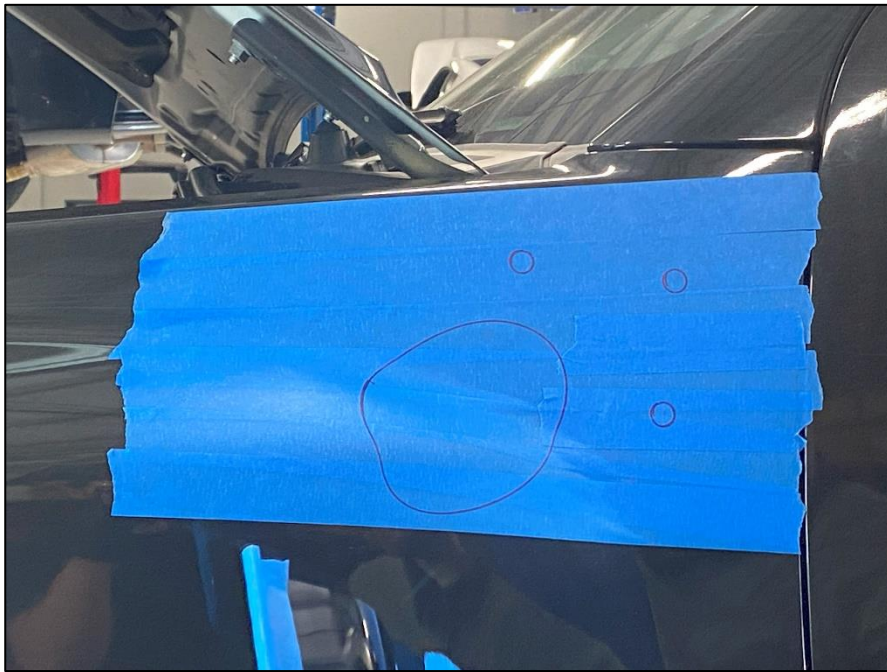

Figure 7

11. Using a Center Punch or Drill, mark the Center of the (3) three smaller holes marked in *Step 9.*

12. Drill out the (3) three smaller holes to 5/8". A Step Bit is preferred, but if you do not have one, slowly work your way up to the bigger Drill Bits. *Figure 8.*

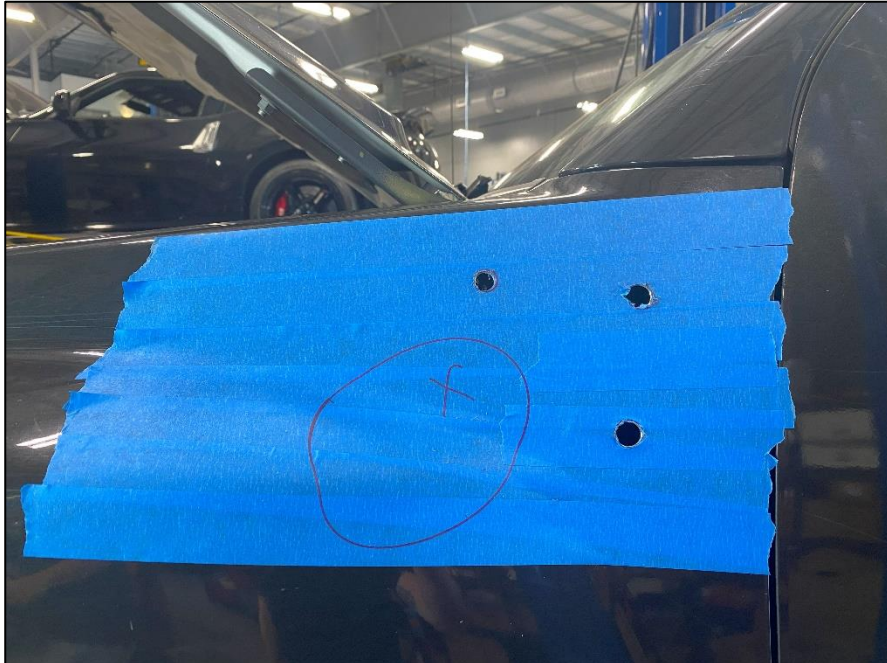

Figure 8

13. Drill a hole in the center of the large outline as a starting point for the next step. *Figure 9.*

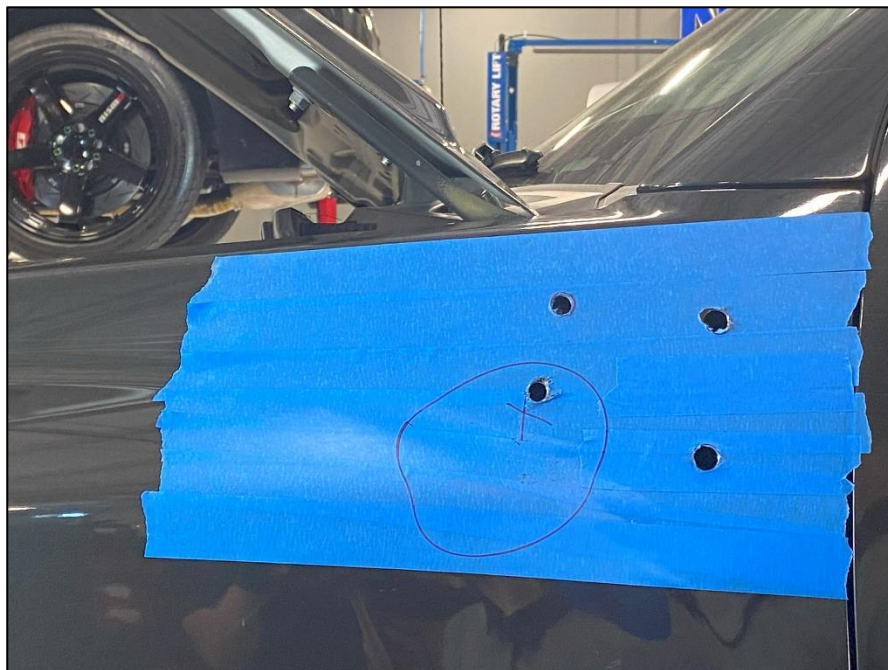

Figure 9

14. Using an Airsaw, Dremel, Sawzall, or another similar tool, cut out the large outline. Be careful and go slowly. Make sure your blade does not go too far into the inside of the fender. *Figure 10.*



Figure 10

15. Remove the Painters Tape.

16. Using the Locating Template, double check fitment.

17. After checking fitment, use a file and clean up the edges of where you cut.

18. Use Touch-Up Paint and paint the edges of where you cut to prevent corrosion. Allow ample time for the paint to cure. *Figure 11.*

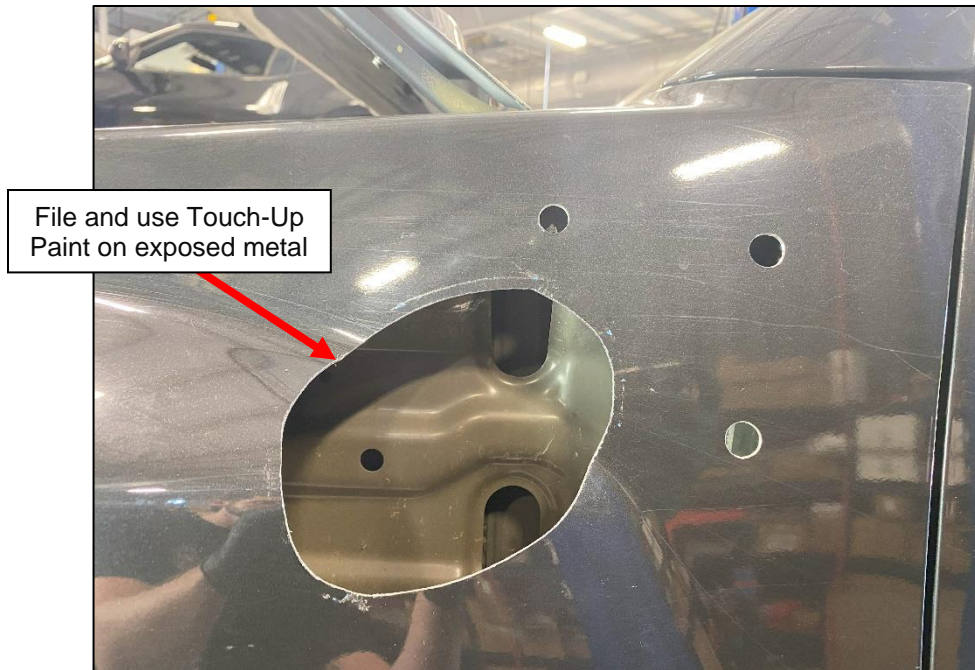

Figure 11

19. After the paint has cured, locate the Snorkel Upright. Position the Snorkel Upright onto the holes cut in *Steps 12-14* and confirm fitment.
20. Locate (3) three M8 x 1.25 Hex Head Screws, 12mm, and (3) three M8 Oversized Washers. Position a Washer over each bolt and apply RTV to the threads of each bolt. Install each bolt from inside the Fender Well into the Snorkel Upright. Tighten by hand at first, and then tighten with a wrench.

NOTE: Do not overtighten the (3) three bolts, as the Snorkel Upright could crack. Tighten enough that the Snorkel Upright is firmly attached and snug to the front fender.

21. Once the Snorkel Upright has been positioned, locate the A-Pillar Bracket. Pull back the weather seal inside of the driver side door. Install the A-Pillar Bracket onto the pinch weld and position it to line up with the Snorkel Upright mounting holes. *Figure 12.*

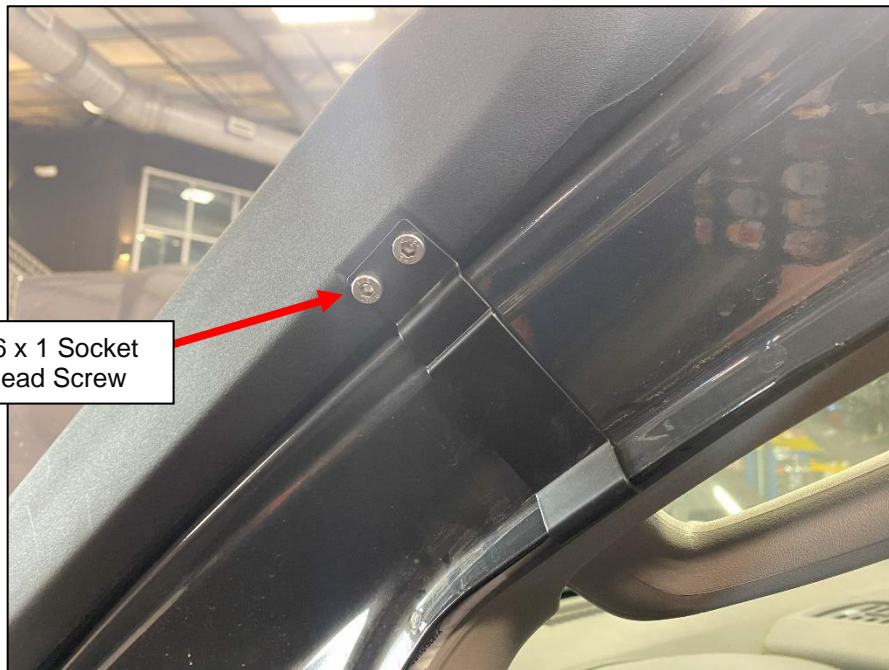

Figure 12

22. Locate (2) two M6 x 1 Socket Head Screws, 10mm. Install them through the A-Pillar Bracket into the Snorkel Upright. Tighten them with an Allen/Hex Key. Seen above in *Figure 12.*

23. Reinstall the weather seal.

24. Locate the Snorkel Inlet Head, Inlet Face, and (4) four M6 x 1 Flat Head Screws, 10mm. Position the Inlet Face over the opening of the Snorkel Inlet Head and secure with the (4) four M6 Screws. *Figure 13.*

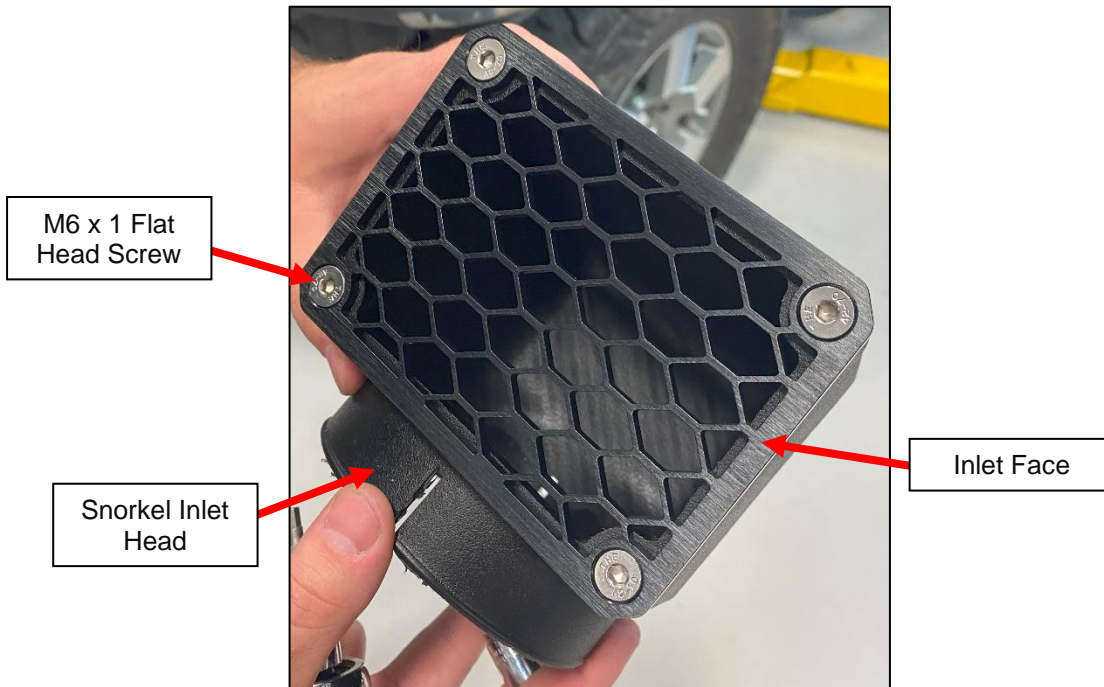

Figure 13

25. Locate the Snorkel Inlet Head assembly and the Black Band Clamp. Install the Black Band Clamp onto the base of the Inlet Head assembly.

26. Install the Snorkel Inlet Head on top of the Snorkel Upright. Align the Inlet Head to the Small tab on the Snorkel Upright and tighten the Black Band Clamp with a screwdriver. *Figure 14.*



Figure 14

27. Locate the Fender Pipe, Silicone Coupler, and (3) three Band Clamps. Install the Silicone Coupler onto the Fender Pipe, and loosely secure with (1) one Band Clamp. Loosely install one more Band Clamp on each side of the assembly as shown below. *Figure 15.*



Figure 15

28. Locate the Rubber Fender Grommet. The Grommet will look different depending on if you are using the OE Airbox or the Z1 Airbox. Install the Rubber Grommet with the Larger Inlet into the opening in the side of the engine bay. Install with the as shown below in *Figure 16*.



Figure 16

NOTE: Steps 29-30 are for users who are using the OE Airbox. If you are using the Z1 Airbox, skip to Step 31.

29. Locate the OE Airbox. Remove the Foam Isolator from the flanged section of the Airbox. *Figure 17.*

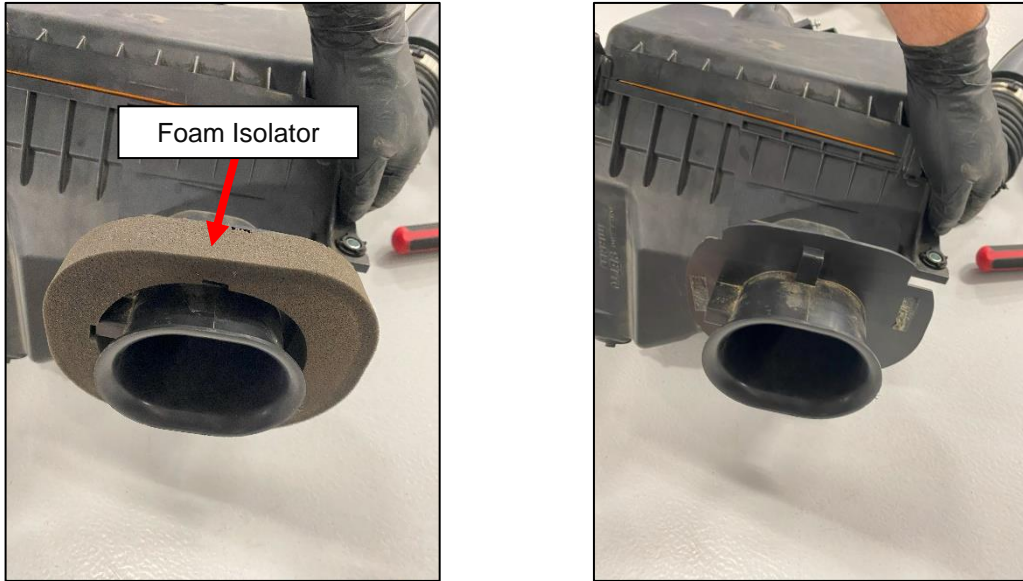

Figure 17

30. Cut the Flanged Edge of the Airbox off using an Airsaw, Cutoff Wheel, or a similar tool. *Figure 18.*



Figure 18

31. Locate your Z1 Airbox and the Large Band Clamp. Place the Large Band Clamp on the Fender Grommet installed in *Step 28*. Reinstall the Z1 Airbox and fit it to the new Fender Grommet as shown. Once positioned, tighten the Large Band Clamp, securing the Airbox in place. *Figure 19*.

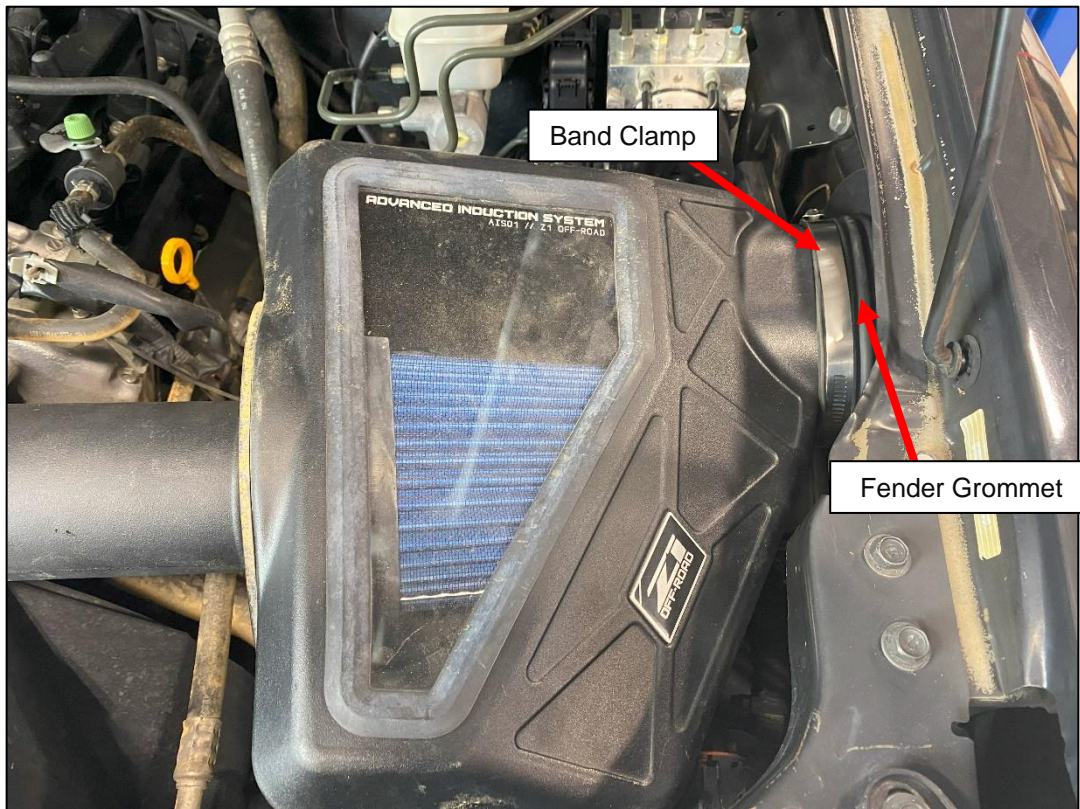

Figure 19

32. Reinstall the Z1 Cold Air Intake. Refer to the [Z1 Xterra Cold Air Intake](#) Installation Manual or the Factory Service Manual if necessary.
33. Locate the Fender Pipe Assembly created in *Step 27*. Position it inside the Driver Side Wheel Well and attach the bend of the Fender Pipe to the Fender Grommet first. Adjust the Band Clamps so they can be tightened, but **DO NOT** tighten yet.

34. Swing the Fender Pipe Assembly up and connect the Silicone Coupler to the Snorkel Upright. Adjust the Band Clamps so they can be tightened, but **DO NOT** tighten yet. *Figure 20.*



Figure 20

35. Adjust the Fender Pipe Assembly accordingly to make sure it sits on the Fender Grommet and Snorkel Upright securely.

36. Adjust and tighten the (3) three Band Clamps on the Fender Pipe Assembly.

37. Double check all fasteners and tighten them as needed.

38. Reinstall the Fender Liner removed in *Step 5*.

39. This Step is optional if you want a Weep Hole or Drain Plug on your Z1 Snorkel. Drill a 3/8" Hole in the bottom of the Snorkel. Once drilled, insert the supplied Drain Plug in the new hole, or it can be left open as a Weep Hole. If you don't want a Drain Plug, skip to *Step 40*. *Figure 21.*

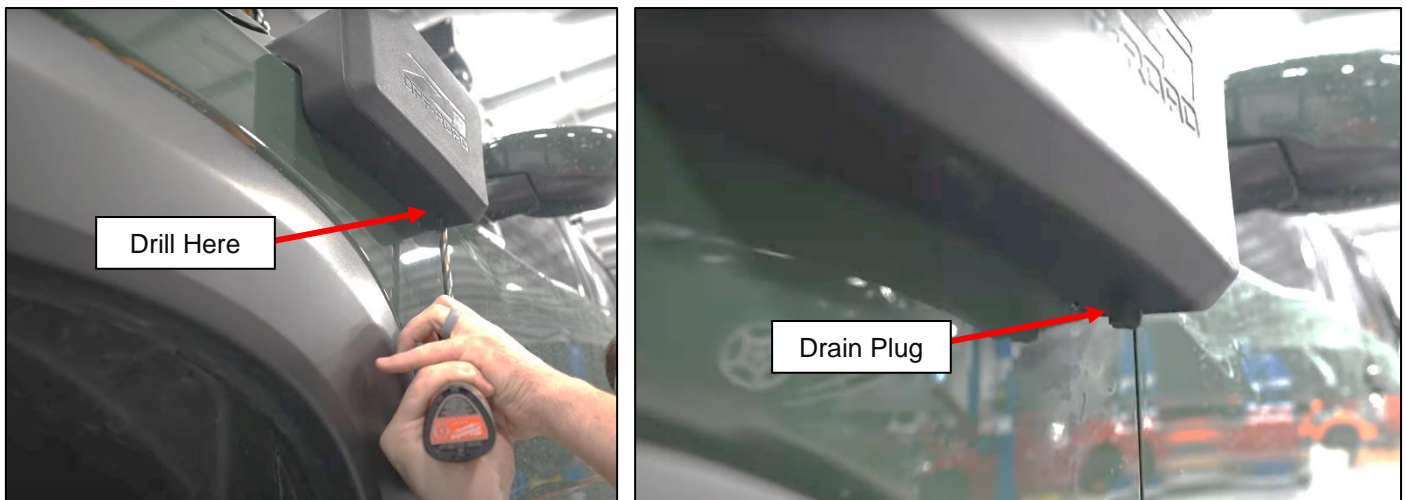

Figure 21

40. Account for and remove tools.

41. Start truck and take vehicle for a test drive.

END

Additional Technical Support:
Contact Z1 Off-Road at info@z1offroad.com
Or call 678-839-8019 between 9am and 6pm ET