

# Z1 300ZX (Z32) ADJUSTABLE FRONT SWAY BAR END LINKS INSTALLATION MANUAL



This Installation Manual is intended for the following models:

1990-1996

Nissan 300ZX Z32

## PROLOGUE:

Study these instructions completely before proceeding to assembly. The installer must have a thorough knowledge of automotive systems operation. If unfamiliar with any of the concepts outlined in this instruction, we recommend the installation be completed by a qualified professional.

## WARNING!

Extreme caution should be taken when performing maintenance or performance upgrades to your vehicle. Please observe and abide by any Warning or Caution labels placed on the various components and tools used when servicing your vehicle. If you have any questions regarding installation or the various components included with the Z1 Motorsports 300ZX (Z32) Adjustable Front Sway Bar End Links, consult with a Professional Mechanic or contact Z1 Motorsports for more information.

## **PARTS INCLUDED:**

Item	Quantity	Description
1	2	Z1 Front Sway Bar End Link
2	2	M10 Steel Washer

## **TOOLS REQUIRED:**

- Hydraulic Jack
- (2) 2-Ton (or greater) Jack Stands
- Ratchet
- Ratchet Extension(s)
- Assorted Metric Wrenches
- Assorted Metric Sockets
- Torque Wrench
- Channel Lock Pliers

## **SAFETY REQUIREMENTS:**

- Always wear safety glasses and any necessary protective garments. If using any fluids, chemicals, or solvents, a respirator is recommended.
- Always turn the ignition to the OFF position and disconnect the NEGATIVE battery terminal.
- Always use properly rated jack stands when working under your vehicle.
- Always keep limbs and parts away from moving drivetrain parts.
- Only operate drivetrain in safe space and well-ventilated areas.

## **BEFORE YOU BEGIN:**

Remove contents from the Z1 Motorsports 300ZX (Z32) Adjustable Front Sway Bar End Links and verify that ALL necessary hardware is present.

## **PROCEDURE:**

1. Place the transmission in Park position (or in Reverse gear if equipped with a manual transmission). Apply the parking brake.
2. Loosen the lugnuts on the front wheels, but do not remove.
3. Locate proper jacking points on vehicle's chassis (refer to vehicle's Owner Manual). Raise and support vehicle using jack & jack stands.
4. Remove front lugnuts and front wheels from car.

5. Remove (1) one nut on each side of the sway bar that connects the OEM Endlink to the Sway bar. *Figure 1.*
6. Remove (1) one nut on each OEM End Link that connects the OEM Endlink to the Third Link. *Figure 1.*

**NOTE:** The use of pliers on the inside of the OEM End Link may be necessary to prevent the End Link from spinning when attempting to loosen the nut attaching it to the suspension components.

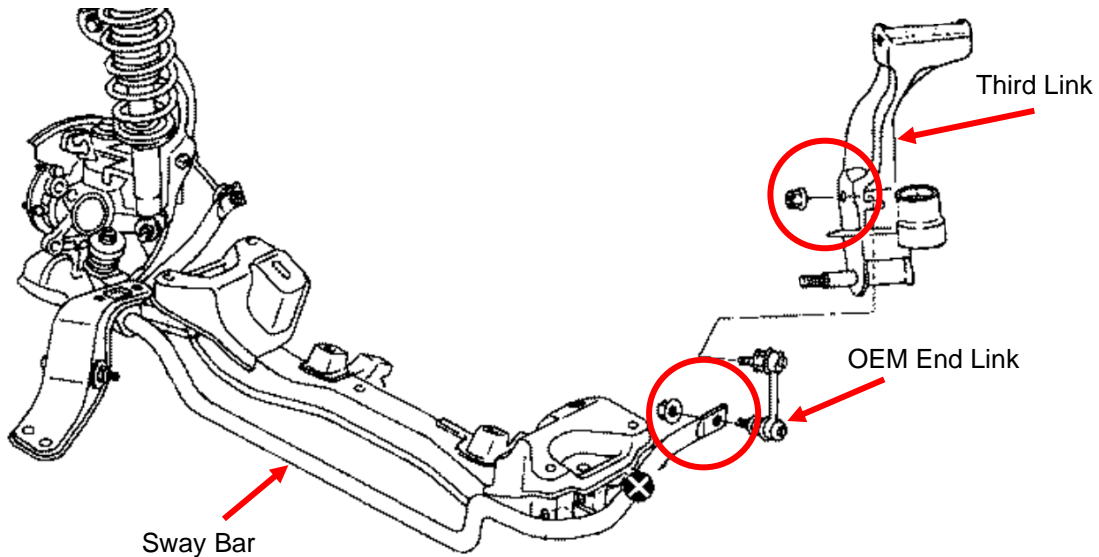
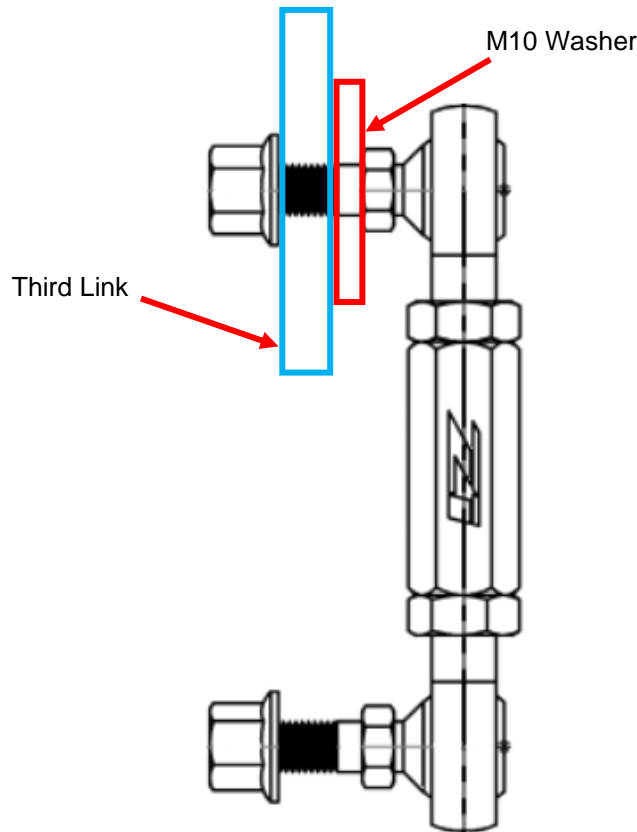

Figure 1

7. Remove OEM Sway Bar Endlinks from the vehicle.
8. Locate new Z1 Adjustable Front Sway Bar End Links, adjust the Z1 End Link length to match the length of the OEM End Link.
9. Using the provided Locknuts, attach the Z1 End Link to the Sway Bar. Do not fully tighten the nuts yet.

10. Locate (2) two M10 Washers and attach the Z1 End Link to the Third Link with the Washer on the End Link Side. *Figure 2.*



*Figure 2*

11. Using the provided Locknuts, attach the Z1 End Link to the Sway Bar. Do not fully tighten the nuts yet.
12. Make final adjustments to the Z1 End Link for desired Sway Bar angle.
13. Using two open end wrenches, tighten the jam nuts on the Z1 End Links.
14. Tighten both nuts connecting the Z1 End Links to the Sway Bar and Third Link to 47 ft-lbs.
15. Reinstall front wheels and lugnuts.
16. Safely lower vehicle from jack stands.
17. Torque front lugnuts to 87 ft-lbs.
18. Inspect vehicle for loose items or tools.
19. Perform a final test drive of the vehicle.

**END**

**Additional Technical Support:**

Contact Z1 Motorsports at [info@z1motorsports.com](mailto:info@z1motorsports.com)

Or call 770-838-7777 between 9am and 6pm ET