

Z1 370Z 2015+ NISMO BUMPER FRONT BRAKE COOLING DUCTS INSTALLATION MANUAL



This Installation Manual is intended for the following models:

2009-2020

Nissan 370Z (w/ 2015+ Nismo Bumper)

PROLOGUE:

Study these instructions completely before proceeding to assembly. The installer must have a thorough knowledge of automotive systems operation. If unfamiliar with any of the concepts outlined in this instruction, we recommend the installation be completed by a qualified professional.

WARNING!

Extreme caution should be taken when performing maintenance or performance upgrades to your vehicle. Please observe and abide by any Warning or Caution labels placed on the various components and tools used when servicing your vehicle. If you have any questions regarding installation or the various components included with the Z1 Motorsports 370Z 2015+ Nismo Bumper Brake Cooling Ducts, consult with a Professional Mechanic or contact Z1 Motorsports for more information.

PARTS INCLUDED:

Item	Quantity	Description
1	1	Driver Bumper Duct
2	1	Driver Inner Bracket
3	1	Driver Outer Bracket
4	1	Passenger Bumper Duct
5	1	Passenger Inner Bracket
6	1	Passenger Outer Bracket
7	8	M6 X 10mm Screw
8	4	M6 X 16mm Screw
9	4	M6 Nylon Lock Nut

TOOLS REQUIRED:

- Hydraulic Jack
- (2) 2-Ton (or greater) Jack Stands
- Ratchet
- Ratchet Extension(s)
- 10mm Socket/Wrench
- 14mm Socket/Wrench
- Flat-head Screwdriver

SAFETY REQUIREMENTS:

- Always wear safety glasses and any necessary protective garments. If using any fluids, chemicals, or solvents, a respirator is recommended.
- Always turn the ignition to the OFF position and disconnect the NEGATIVE battery terminal.
- Always use properly rated jack stands when working under your vehicle.
- Always keep limbs and parts away from moving drivetrain parts.
- Only operate drivetrain in safe space and well-ventilated areas.

BEFORE YOU BEGIN:

Remove contents from the Z1 Motorsports 370Z 2015+ Nismo Bumper Brake Cooling Ducts and verify that ALL necessary hardware is present.

PROCEDURE:

1. Place the transmission in Park position (or in Reverse gear if equipped with a manual transmission). Apply the parking brake.
2. Locate proper jacking points on vehicle's chassis (refer to vehicle's Owner Manual). Raise and support vehicle using jack & jack stands.
3. Unlatch and raise vehicle's hood. Apply hood prop.

Use the diagrams below as reference for the following steps:

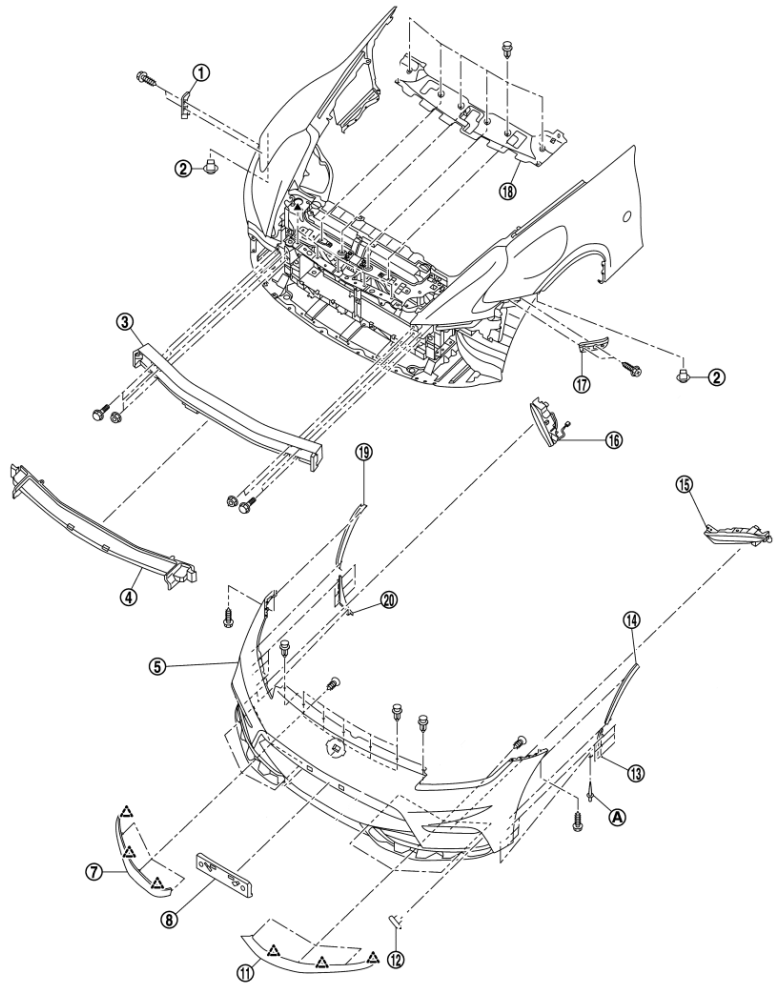
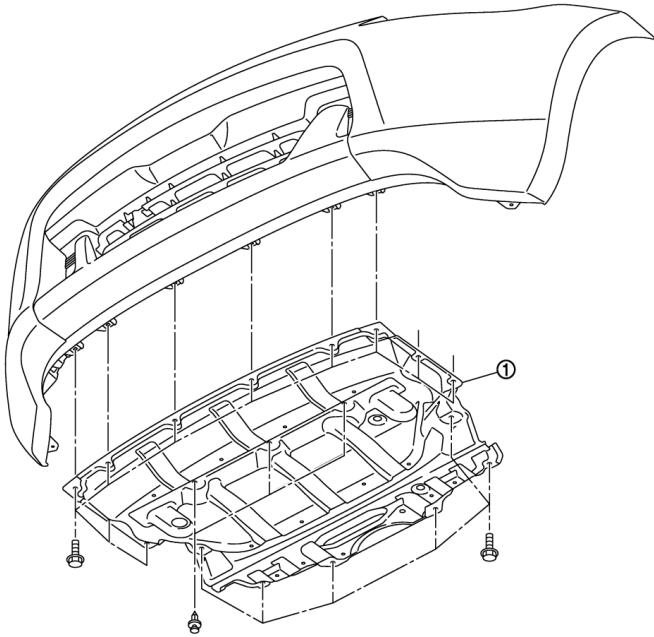

4. Remove (7) plastic pop clips securing upper of bumper fascia to vehicle at radiator core support.
5. Remove plastic clips and peel back front wheel liners to reveal (1) mounting screw at each side which mounts the top corners of the bumper fascia to the fender. Remove mounting screws.

Note: Turn front wheels to the inside of the side you are working on for increased accessibility.

6. Remove the lower engine splash shield (undershroud). Fasteners will be an assortment of 10mm screws and plastic panel clips. Use a flat blade screwdriver to gently pry up the pop clips.
7. With a light pull motion, carefully disengage bumper fascia from clips on vehicle.
8. If present, disconnect DRL harness connector. Remove bumper fascia and set aside.
9. If equipped with DRLs, remove DRL assembly mounting screws and clips. Remove DRL assemblies.
10. Locate both bumper ducts, all (4) brackets, and all (8) M6 X 10mm Screw.

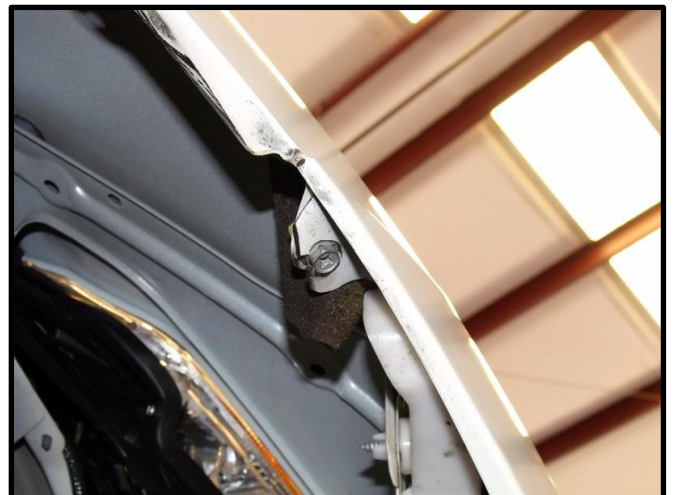

11. Attach the brackets to each panel using (2) M6 x 10mm screws on each, as shown below. Do not fully tighten the screws yet.

Left (Driver) Side Panel and Brackets



Right (Passenger) Side Panel and Brackets



Note: The hardware used in the images in this manual were samples and may differ from production

12. Position the panels onto the backside of the bumper fascia (as shown below).
13. Secure the panels to the bumper fascia with the supplied (4) M6 x 16mm screws and (4) M6 nylon lock nuts (as shown).



14. Once the panels are in place, align them as best you can so that there are no gaps when viewing from the front and tighten the (2) bolts on each bracket.
15. Follow steps #5 through #8 in reverse order to reinstall front bumper fascia.
16. Properly lower vehicle from jack stands.
17. Inspect vehicle for loose tools/items
18. Lower hood of vehicle.
19. Perform a final test drive of vehicle.

END

Additional Technical Support:

Contact Z1 Motorsports at info@z1motorsports.com
Or call 770-838-7777 between 9am and 6pm ET