

# Z1 BILLET SWAY BAR BRACKETS INSTALLATION MANUAL



This Installation Manual is intended for the following models:	
2003-2008	Nissan 350Z (Rear Only)
2009-2020	Nissan 370Z (Front and Rear)
2003-2007	Infiniti G35 Coupe (Rear Only)
2003-2006	Infiniti G35 Sedan (Rear Only)
2007-2008	Infiniti G35 Sedan (Front and Rear)
2008-2013	Infiniti G37 (Front and Rear)
2023+	Nissan Z

## PROLOGUE:

Study these instructions completely before proceeding to assembly. The installer must have a thorough knowledge of automotive systems operation. If unfamiliar with any of the concepts outlined in this instruction, we recommend the installation be completed by a qualified professional.

## WARNING!

Extreme caution should be taken when performing maintenance or performance upgrades to your vehicle. Please observe and abide by any Warning or Caution labels placed on the various components and tools used when servicing your vehicle. If you have any questions regarding installation or the various components included with the Z1 Motorsports Billet Sway Bar Brackets, consult with a Professional Mechanic or contact Z1 Motorsports for more information.

## **PARTS INCLUDED:**

Item	Quantity	Description
1	2	Z1 Billet Sway Bar Bracket
2	2	Energy Suspension Bushing (w/ grease packet)

## **TOOLS REQUIRED:**

- Hydraulic Jack
- (2) 2-Ton (or greater) Jack Stands
- Ratchet
- Ratchet Extension(s)
- Assorted Metric Sockets (up to 21mm)
- Assorted Metric Wrenches (up to 21mm)

## **SAFETY REQUIREMENTS:**

- Always wear safety glasses and any necessary protective garments. If using any fluids, chemicals, or solvents, a respirator is recommended.
- Always turn the ignition to the OFF position and disconnect the NEGATIVE battery terminal.
- Always use properly rated jack stands when working under your vehicle.
- Always keep limbs and parts away from moving drivetrain parts.
- Only operate drivetrain in safe space and well-ventilated areas.

## **BEFORE YOU BEGIN:**

Remove contents from the Z1 Motorsports Billet Sway Bar Brackets and verify ALL necessary hardware is present.

Sway bar diagrams are provided on the last two pages of this manual for all applicable models and years. Due to variations throughout the years, refer to the Factory Service Manual (FSM) for torque specs.

## **PROCEDURE:**

1. Place the transmission in Park position (or in Reverse gear if equipped with a manual transmission). Apply the parking brake.
2. Locate proper jacking points on vehicle's chassis (refer to vehicle's Owner Manual). Raise and support vehicle using jack & jack stands.

### **Front:**

3. Remove engine undershroud, set aside.
4. Remove (1) nut on each side of sway bar that connects it to the bottom of each end link (circled below).
5. Remove (2) nuts on each sway bar bracket that connect them to the vehicle.
6. Remove OEM sway bar and brackets from vehicle.
7. Remove old sway bar brackets and bushings from sway bar.
8. Position new bushings on sway bar on the outside of bushing flange (as shown). Grease bushings with supplied grease packets.



9. Position Z1 Brackets around bushings (as shown above).
10. Reattach sway bar brackets to vehicle using the fasteners removed in step #5.
11. Reattach end links to sway bar using the nut removed in step #4 on each side.
12. Reattach engine undershroud.
13. Properly lower vehicle from jack stands.
14. Inspect vehicle for loose tools/items
15. Perform a final test drive of vehicle.



**Rear:**

3. Remove necessary exhaust components to gain access to rear sway bar.
4. Remove (1) nut on each side of sway bar that connects it to the bottom of each end link (circled below).
5. Remove (2) bolts/nuts on each sway bar bracket that connect them to the vehicle.
6. Remove OEM sway bar and brackets from vehicle.
7. Locate new Z1 brackets and bushings.
8. Remove old sway bar brackets and bushings from sway bar.
9. Position new bushings on sway bar on the outside of bushing flange (as shown). Grease bushings with supplied grease packets.
10. Position Z1 Brackets around bushings (as shown).
11. Reattach sway bar brackets to vehicle using the fasteners removed in step #5.
12. Reattach end links to sway bar using the nut removed in step #4 on each side.
13. Reattach exhaust components.
14. Properly lower vehicle from jack stands.
15. Inspect vehicle for loose tools/items.
16. Perform a final test drive of vehicle.

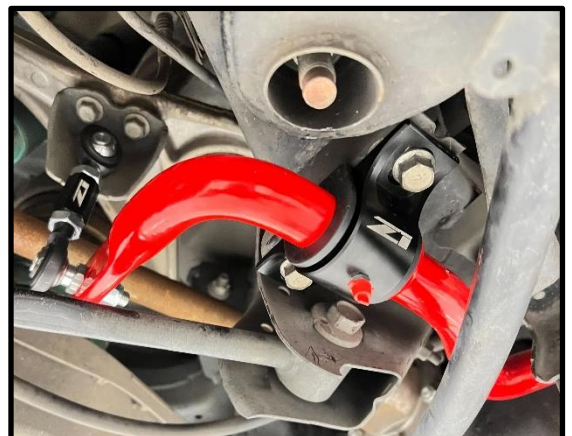
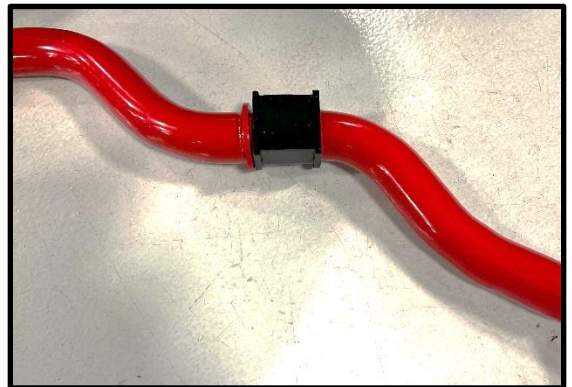

**END**

**Additional Technical Support:**  
 Contact Z1 Motorsports at [info@z1motorsports.com](mailto:info@z1motorsports.com)  
 Or call 770-838-7777 between 9am and 6pm ET

Front Stabilizer Bar Diagrams:

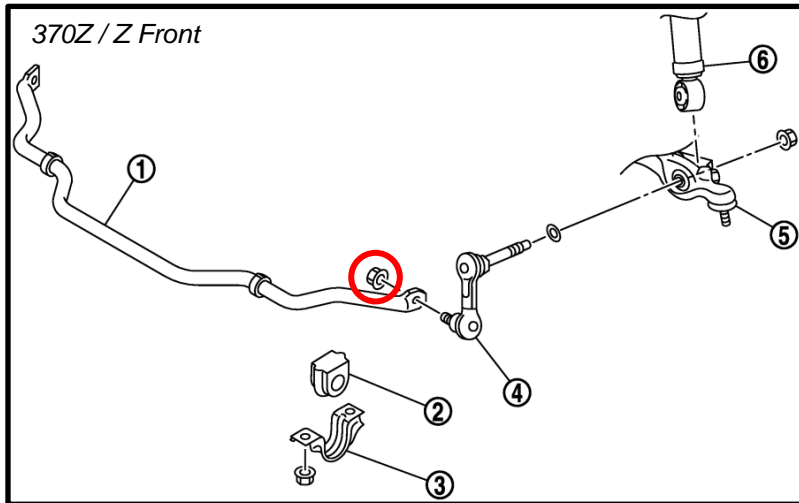
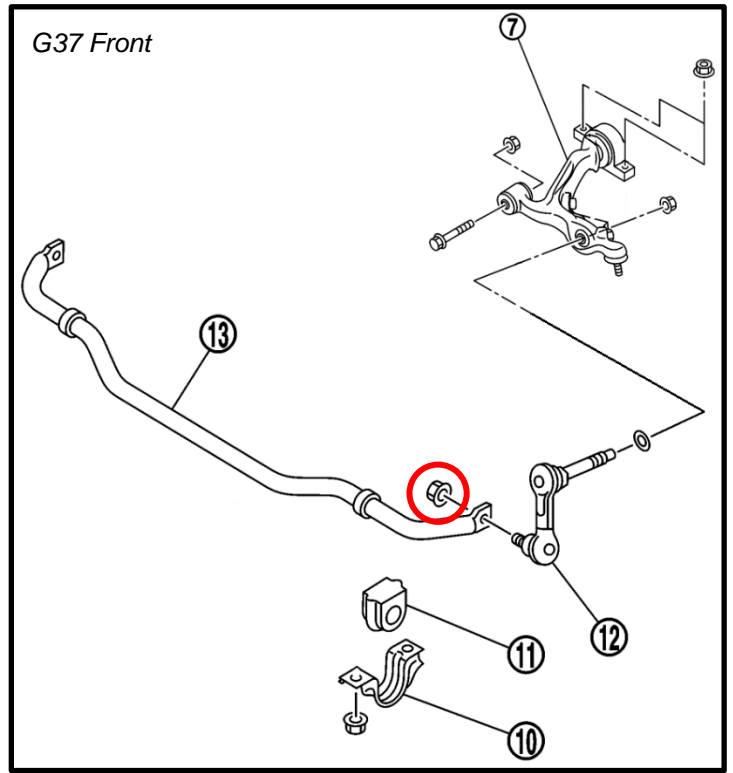
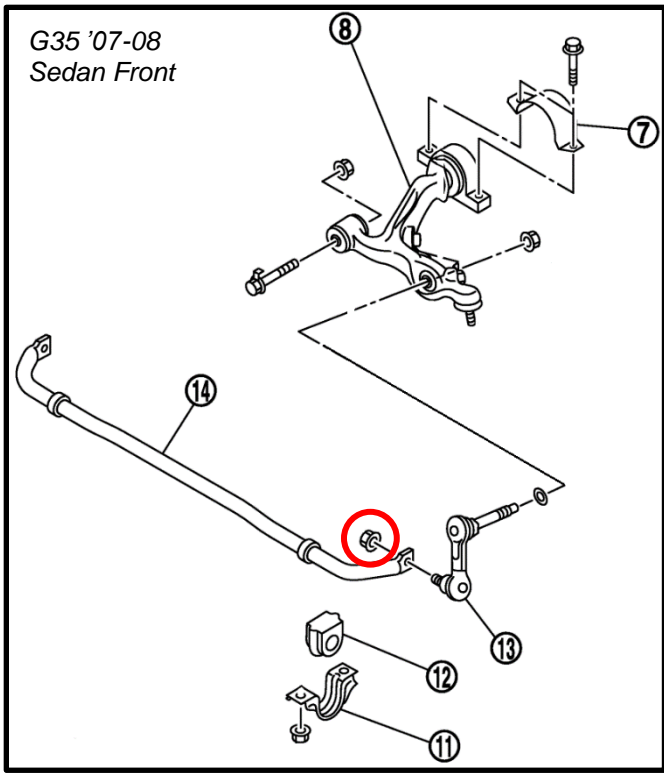

## Rear Stabilizer Bar Diagrams:

