

Z1 350Z VQ35DE FUEL RETURN KIT INSTALLATION MANUAL



This Installation Manual is intended for the following models:

2003-2006	Nissan 350Z
2003-2007	Infiniti G35 (Coupe)

PROLOGUE:

Study these instructions completely before proceeding to assembly. The installer must have a thorough knowledge of automotive systems operation, safety, and sound maintenance practices. If unfamiliar with any of the concepts outlined in this instruction, we recommend the installation be completed by a qualified professional.

WARNING!

Extreme caution should be taken when performing maintenance or performance upgrades to your vehicle. Please observe and abide by any Warning or Caution labels placed on the various components and tools used when servicing your vehicle. If you have any questions regarding installation or the various components included with the Z1 Motorsports 350Z / G35 VQ35DE Fuel Return Kit, consult with a Professional Mechanic or contact Z1 Motorsports for more information.

Table of Contents

(Click below links)

I.	Parts Included	3
II.	Introduction : Tools and Safety.....	4
III.	Fuel Pump Upgrade	5 thru 9
IV.	Fuel Regulator Delete	9 thru 18
V.	Fuel Damper Installation	19 thru 20
VI.	Z1 Fuel Pressure Regulator	20 thru 22
VII.	Fuel Lines and Fuel Filter	23 thru 30

PARTS INCLUDED:

Item	Quantity	Description
1	1	VQ Fuel Port Kit
2	1	Fuel Damper, OEM
3	1	Fuel Pressure Regulator, Z1
4	1	Fuel Filter, In-Line, External, w/ 10 Micron Filter
5	1	Mount, Fuel Filter
6	1	Mount, Fuel Pressure Regulator
7	1	Gauge, Mini, Fuel Pressure, 0-100psi, 1/8" NPT

Fuel Pressure Regulator Delete Kit – Z198247

Item	Quantity	Description
1	1	DE Fuel Pressure Regulator Delete
2	1	PTFE Flexible In-Tank Fuel Tube, 10mm ID, 210mm Length
3	1	Fuel Pump Bulkhead Fitting, 3/8" Quick Disconnect
4	1	Bulkhead Nut, 6AN
5	2	Washer, PTFE Bulkhead
6	2	Hose Clamps, 9.5-11mm

OE VQ35DE Fuel Rail Fuel Return Line Kit – Z198281 (350Z)

Item	Quantity	Description
1	1	Fuel Line, Pump Outlet to External Filter, Straight AN, 1570mm/61.81in Length
2	1	Fuel Line, Filter Outlet to Damper Inlet, Straight to 90, 1365mm/53.75in Length
3	1	Fuel Line, Z1 Regulator to Factory Fuel Feed, 45 to 45 AN, 600mm/23.6in Length
4	1	Fuel Line, Damper Outlet to FPR Inlet

OE VQ35DE Fuel Rail Fuel Return Line Kit – Z198282 (G35 Coupe)

Item	Quantity	Description
1	1	Fuel Line, Pump Outlet to External Filter, Straight AN, 1800mm/70.87in Length
2	1	Fuel Line, Filter Outlet to Damper Inlet, Straight to 90, 1365mm/53.75in Length
3	1	Fuel Line, Z1 Regulator to Factory Fuel Feed, 45 to 45 AN, 600mm/23.6in Length
4	1	Fuel Line, Damper Outlet to FPR Inlet

Fuel Line Hardware Kit – Z198278

Item	Quantity	Description
1	2	ORB Fittings, 6AN
2	2	Sealing Bonded Washers, AN
3	1	Quick Disconnect, 5/16", 6AN Male, Firewall
4	1	Quick Disconnect, 3/8", 6AN Male, Pump Outlet
5	36in	Silicon Vacuum Hose, 4mm
6	1	Grommet, Fuel Pump
7	1	O-Ring, Fuel Tank
8	1	Clamp, Loop, 1/2" ID, 1-5/16" Length
9	2	Clamp, Spring

OE VQ35DE Fuel Rails Fuel Return Supplement Kit – Z198279

Item	Quantity	Description
1	1	Clamp, Loop, 1/2" ID, 1-5/16" Length
2	1	ORB Fitting Plug, 6AN w/ O-ring
3	2	Bolt, Flanged, M6 x 1.0mm 25mm Length
4	2	Screw, Flanged, Stainless Steel, M6 x 1mm, 30mm Length

TOOLS REQUIRED:

- 2-Ton or Greater Hydraulic Jack
- (2) 2-Ton (or greater) Jack Stands
- (2) Wheel Chocks
- Rags
- Zip Lock Bags (assort hardware)
- Fuel Line Quick Disconnect Tool
- Ratchet w/ Extensions
- Assorted Metric Sockets / Wrenches
- 2.5mm Allen/Hex Key
- 4mm Allen/Hex Key
- Flat Head Screwdriver
- Inch lbs. Torque Wrench
- Channel Lock Pliers
- File
- Snips
- Dremel w/ Flat Tip Bit
- Wire Strippers
- Wire Crimp Tool
- AN Wrenches
- 9/16 Drill Bit

SAFETY REQUIREMENTS:

- Always wear safety glasses and any necessary protective garments. If using any fluids, chemicals, or solvents, a respirator is recommended.
- Always turn the ignition to the **OFF** position and disconnect/secure the **NEGATIVE** battery terminal.
- Always use properly rated jack stands when working under your vehicle.
- Always keep limbs and parts away from rotating and moving drivetrain parts.
- Only operate drivetrain in safe space and well-ventilated areas.

WARNING: NO FIRES, SPARKS, OR SMOKING. WORK IN A WELL-VENTILATED AREA.

BEFORE YOU BEGIN:

Prior to disassembly of vehicle or maintenance, please remove contents from the Z1 Motorsports 350Z VQ35DE Fuel Return Kit and verify that **ALL** necessary hardware is accounted for in accordance with the Parts Included table on page 3.

The full Z1 350Z Fuel Return Kit is made up of several different Z1 products. The procedures below will be broken up into various sections specific to each product. Depending on the configuration of products you chose for your fuel system, it may require jumping around to different sections of this guide. Many of the components and modifications required will depend on what options you choose, pay attention to the bold and underlined notes regarding specific steps. It is highly recommended to read through this entire manual to get an idea of what needs to be done before proceeding with the work.

All provided fittings are AN, ORB, or include sealing washers. **DO NOT** add your own thread sealant or PTFE sealant tape unless instructed. If available, please use specified AN fitting wrenches. Aluminum fittings (AN) and lines such as the ones included in this kit do not need to be torqued over tightened. **Over tightening AN fittings can compromise the shape and sealing ability resulting in fuel leaks or fire mishap.**

PROCEDURE

Fuel Pump Upgrade:

1. Place the transmission in Park position (or in Reverse gear if equipped with a manual transmission). Apply the parking brake.
2. Locate proper jacking points on vehicle's chassis (refer to vehicle's Owner Manual). Raise and support vehicle using jack & jack stands.
3. It is recommended to install this kit with the gas tank NOT full. If the fuel gauge indicates the level shown in diagram at right or more, drain some fuel before continuing (or just drive the car). It does not need to be empty, but the less fuel in the tank the cleaner the installation.

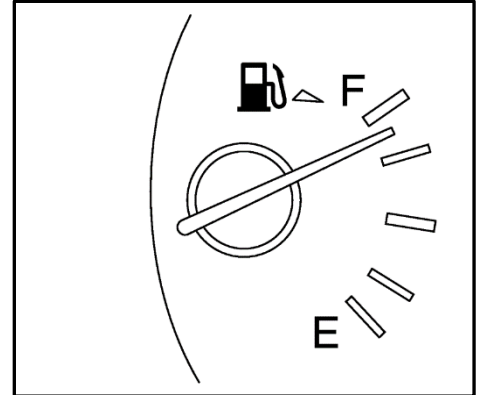

4. It is now time to release the fuel system pressure. There are a couple ways to do this:
 - a. If you have access to CONSULT:
 - i. Turn ignition switch ON.
 - ii. Perform "FUEL PRESSURE RELEASE" in "WORK SUPPORT" mode with CONSULT.
 - iii. Start engine.
 - iv. Wait for engine to run out of fuel and stall.
 - v. Crank engine over two or three times to release remaining fuel pressure.
 - vi. Turn ignition switch OFF
 - b. If you do not have access to CONSULT:
 - i. Disconnect the electrical connector on the top of the fuel tank.
 - ii. Start engine.
 - iii. Wait for engine to run out of fuel and stall.
 - iv. Crank engine over two or three times to release remaining fuel pressure.
 - v. Turn ignition switch OFF.
5. Remove the gas filler cap to release any pressure left in the tank.
6. Assure the ignition is in the OFF position and disconnect/secure the **NEGATIVE** battery terminal.

- Open the compartment behind the passenger seat and remove the shelf and plastic cover. Then remove the thin fuel pump metal access panel by rotating the plastic clips clockwise 90° (shown below).



- Remove the fuel pump access panel and set aside. The wiring harness will remain attached through the grommet, just rotate the cover out of the way.
- It is recommended to clean the top of the OE fuel top hat and surrounding areas to prevent dirt or contaminants from falling into the fuel tank during removal.
- Place a rag around the OE fuel feed hose ① on the OE fuel top hat, and then disconnect the hose by pressing the sides of the retaining clip ② in and pulling the hose away. If the clip comes off with the hose that is fine, it can be put back on later.

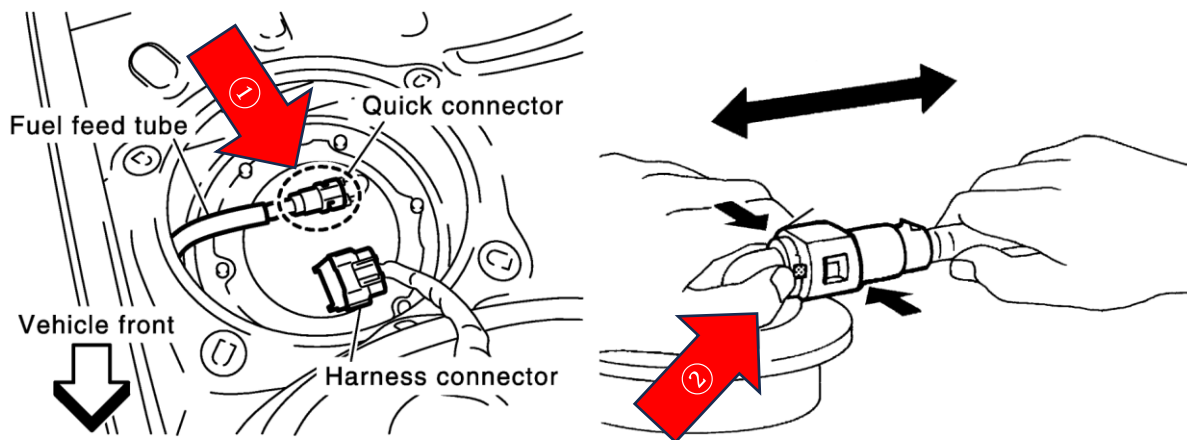

- Using an 8mm socket, remove the (6) M5 bolts securing the OE fuel top hat to the fuel tank.
- Carefully lift upwards to begin removing the fuel pump basket assembly. There is an internal siphon hose connected to the basket that needs to be removed. Once the basket is about halfway out, disconnect the siphon hose as shown in the diagram at right.

Note: The image at right shows a modified 370Z basket assembly that is fully removed from the car to better show the siphon hose. It is recommended to disconnect the siphon hose prior to fully removing the basket assembly.

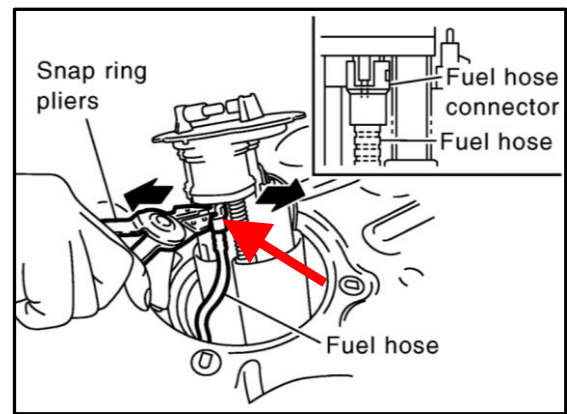

13. Once the siphon hose is disconnected, fully remove the fuel pump basket assembly. Be careful not to bend or damage the floater on its way out.
14. Depending on how much fuel was in your tank, the basket assembly will likely be full of fuel, drain any fuel into an appropriate container.
15. Move to a clean worktable to begin disassembly of the OE fuel basket.
16. Compress the top hat/spring and using flathead screwdriver or your finger, release the locking tab shown below and separate the top and bottom of the basket assembly.

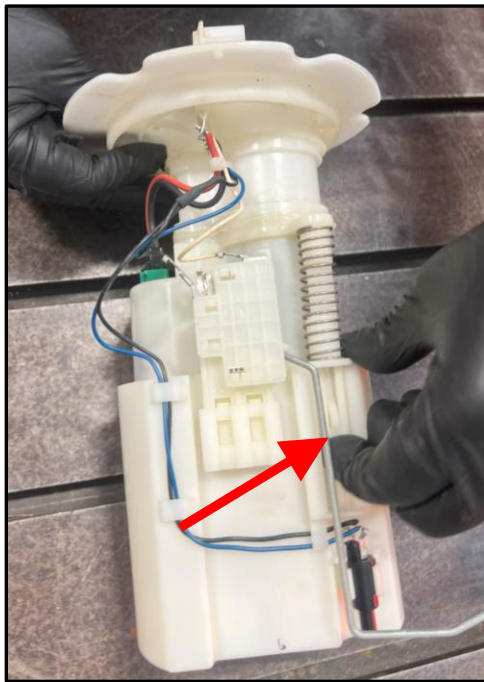

17. Once the halves are separated, disconnect the electrical connector on the top of the OE fuel pump.

18. Remove the fuel pump sock/pre-filter, then remove the plastic fuel pump retainer piece (shown below) that is held in with 3 tabs. Finally, remove the fuel pump from the housing.

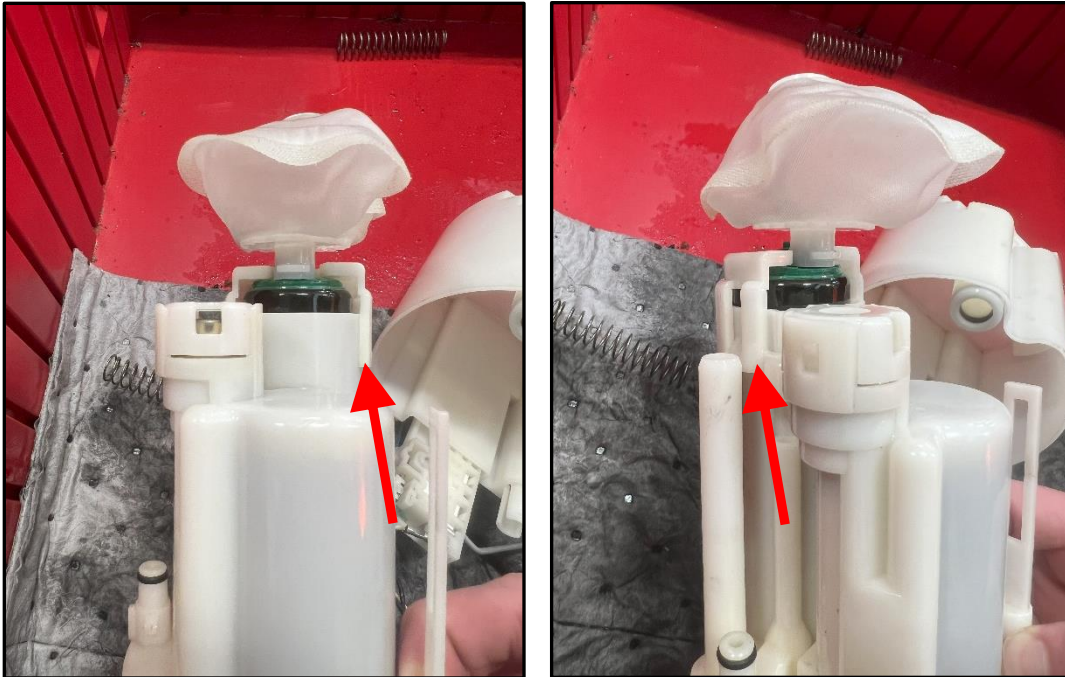

Note: The images above are shown with the new fuel pump already installed.

19. If you are replacing your OEM fuel pump with a 340-style fuel pump or equivalent, most are taller than the factory fuel pump and will require the fuel pump and the OE fuel pump retainer to be modified to fit the taller pump. Using a file or Dremel, carefully remove/file the tabs on the bottom of the fuel pump and some material from the bottom of each of the channels on the retainer piece.

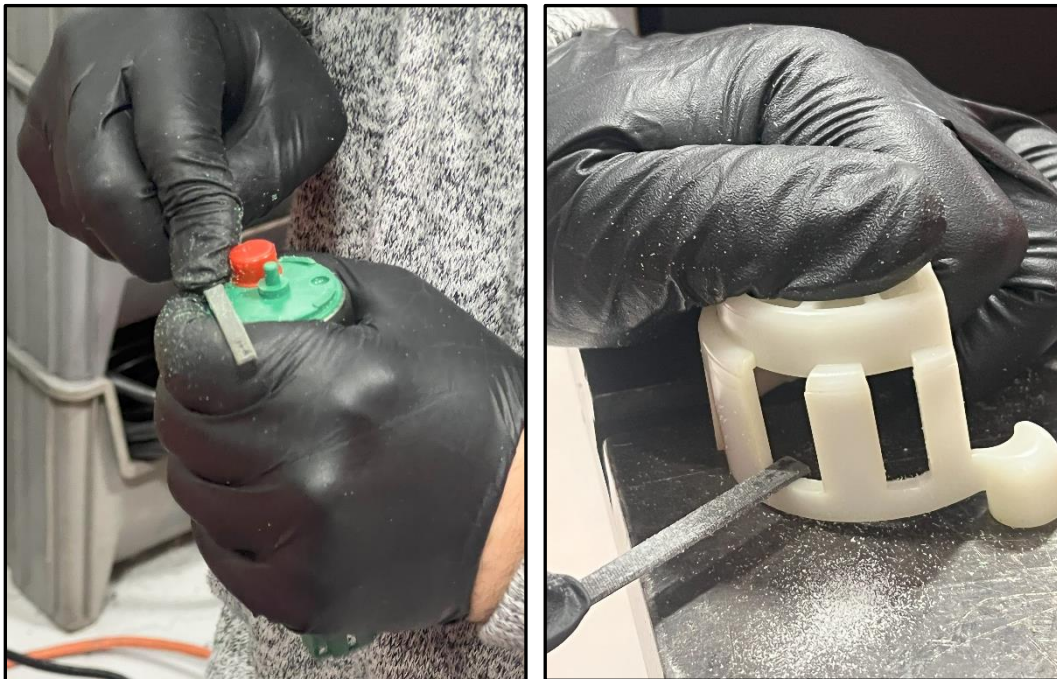

Note: If installing any larger than a 340-style fuel pump, further modification to the fuel pump retainer will be required or an alternative fuel housing assembly will be required.

20. Using the provided new Viton (rubber-like) Z1 fuel pump grommet over the fuel pump outlet, install the fuel pump into fuel pump housing and secure it in place with the modified retainer. Install the OE fuel pump sock onto the new pump. If your OE sock is damaged, you can use the one supplied with the fuel pump.

If you are using a pump with the same factory style connector, plug the OE connector into the fuel pump. If you are using a pump that needs to be wired in, splice/crimp the wires to the wire on the OE connector.



Fuel Regulator Delete:

21. Using a flat head screwdriver, remove the retainer securing the OE fuel pressure regulator (shown below).

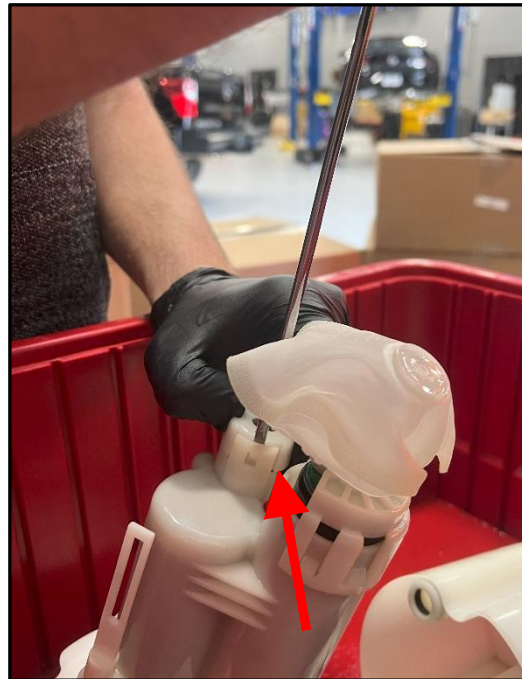

22. Using a pick or flat head screwdriver, remove the OE fuel pressure regulator (FPR) from the fuel basket housing (as shown below).



23. Insert the Z1 Regulator Delete into the opening where the OE FPR was (as shown below). The barb on the bottom of the regulator delete can rotate, so the orientation of it does not matter at this step.

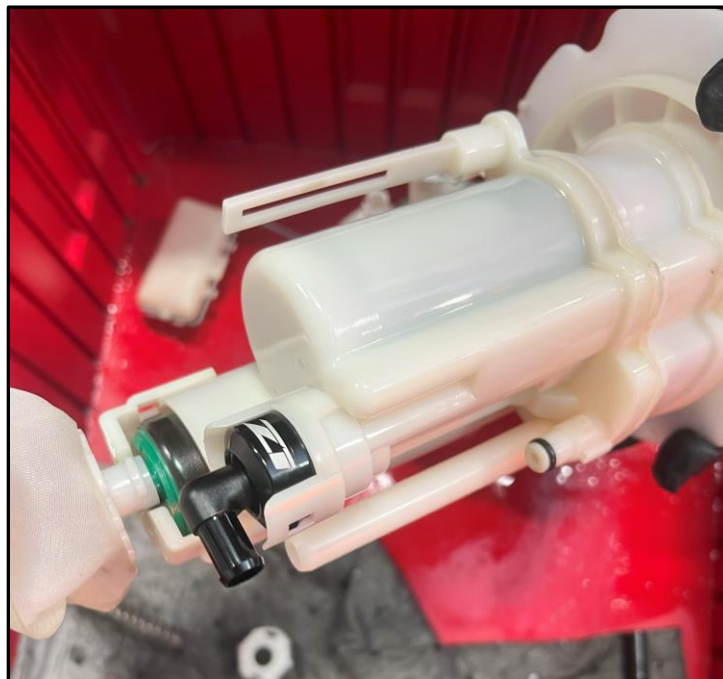

24. With a small screw clamp on the end, install one side of the black PTFE fuel tubes onto the regulator delete nipple fitting.

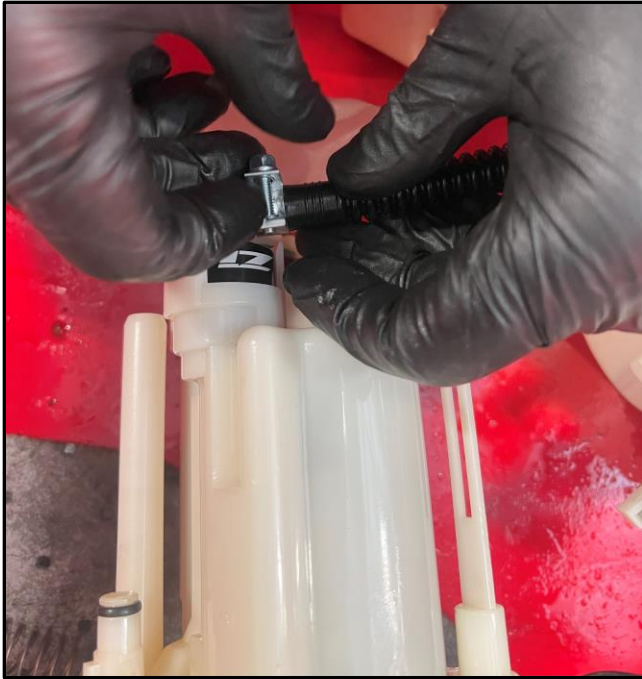

25. The fuel tube will bend up towards the top hat and meet up with a bulkhead fitting that will be installed in the top hat in the next steps.

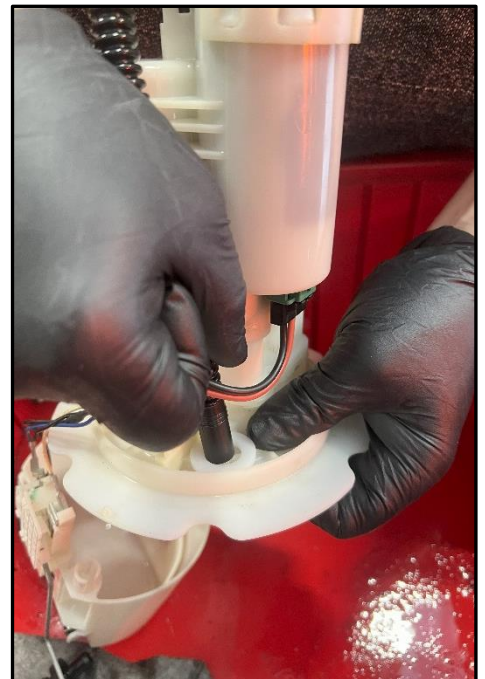
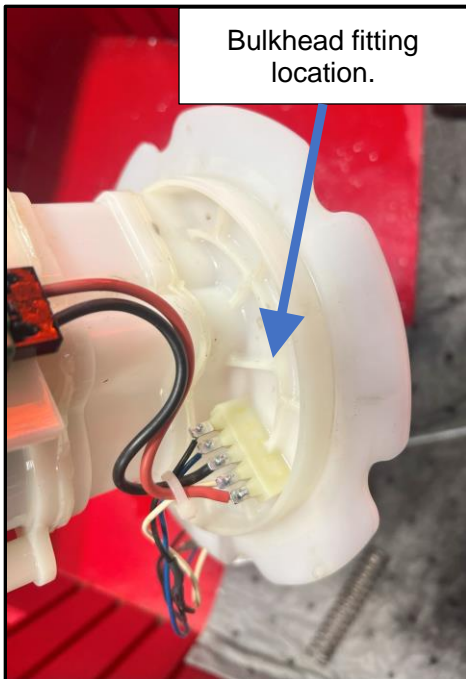

26. Using a Dremel and flat tip bit, remove the webbing support on the underside of the top hat to allow the bulkhead fitting's washer to sit flush (as shown below). There isn't a great spot to hold the basket assembly, but we found using a vice on the OE feed port worked best.

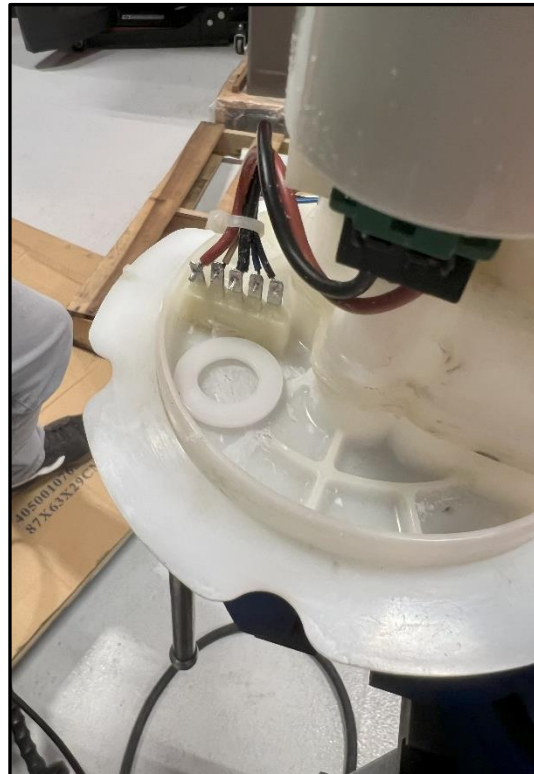
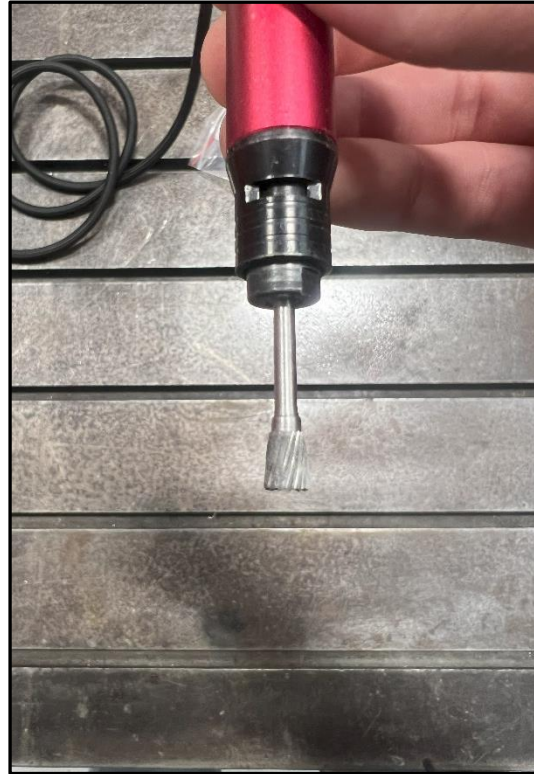
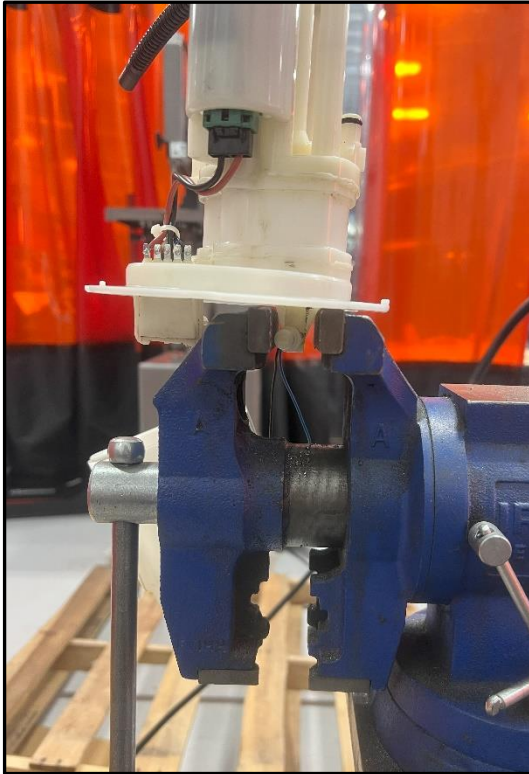

27. Once the webbing has been removed, position the PTFE bulkhead washer on the underside of the top hat and mark the center with a sharpie. Then, flip the top hat over and hold it up to the light and place the 2nd PTFE bulkhead washer on the top of the top hat, and mark the top of the top hat.

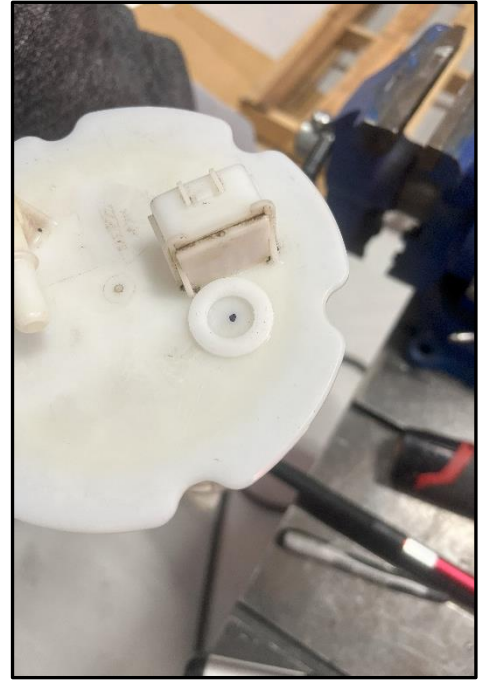
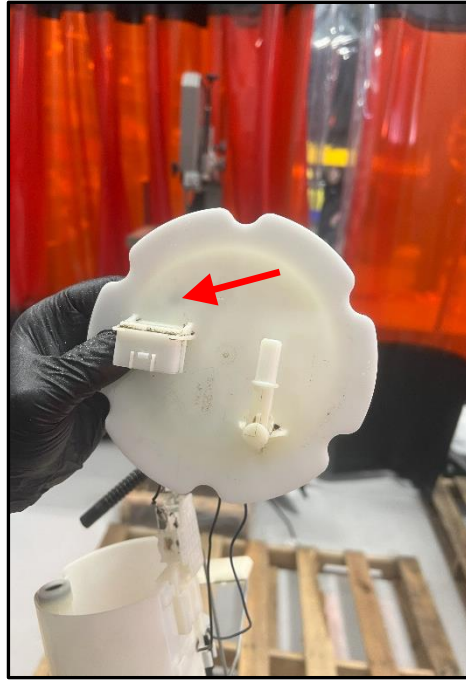

28. Drill the marked spot out to 9/16", debur/clean up the edges, and with a PTFE bulkhead washer on each side install the bulkhead fitting and nut onto the top hat (as shown below).



29. Using a file or Dremel, remove some material on the plastic webbing on the side of the fuel pump housing. This will allow the PTFE fuel tube to sit nicer when routed to the bulkhead fitting.

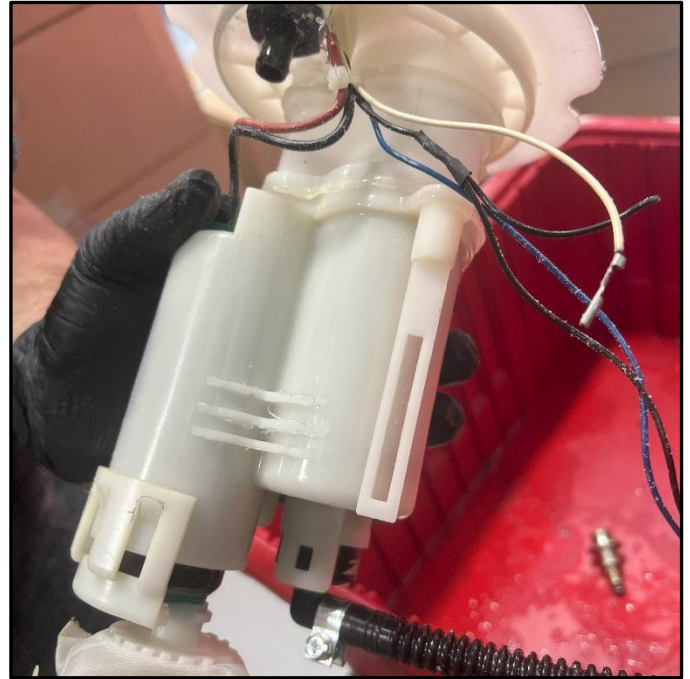
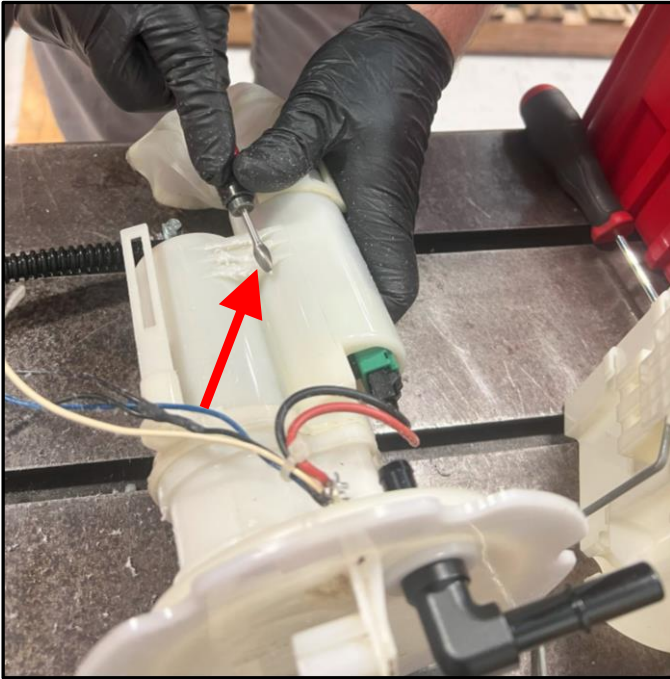

30. With the other screw clamp on the end, attach the other end of the PTFE fuel tube to the bulkhead fitting installed in the previous step.

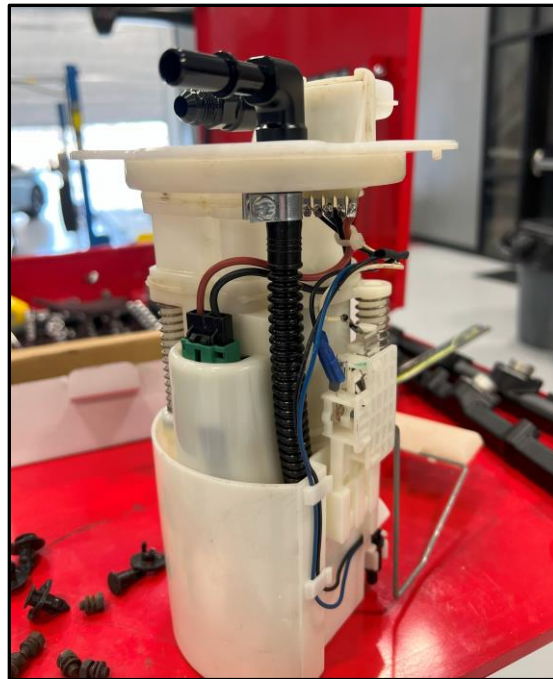

31. Next, install the larger (3/8in) quick disconnect threaded 6AN adapter onto the OE pump outlet on the top hat.

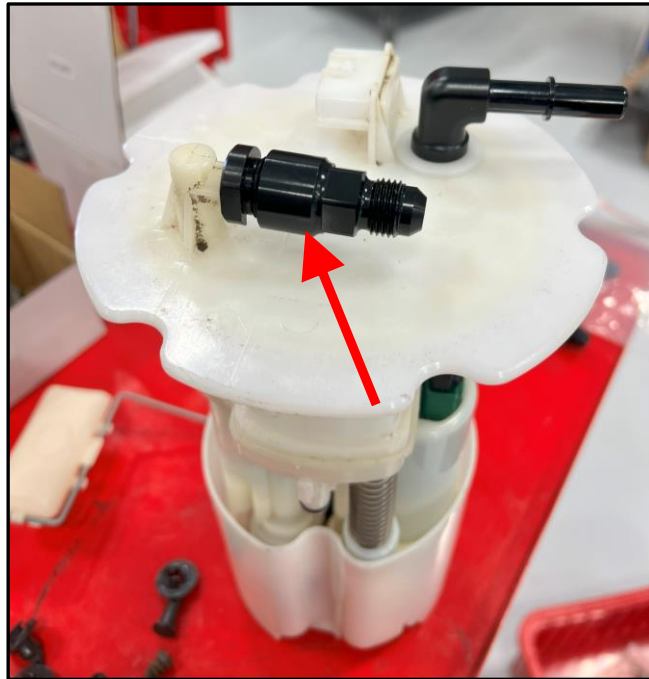

32. At the bottom of the lower basket there is a small yellow plastic piece that is part of the venturi refill system. This piece directs the output of the fuel that is bled off by the fuel pressure regulator. When you upgrade your fuel pump and increase the amount of fuel, the regulator must relieve at low idle situations. This venturi component can become a restriction causing high fuel pressure at idle. To increase the amount this piece can flow, you must slightly drill out the orifice on the bottom. The orifice is roughly 0.050" when unmodified.

Using pliers or a pick, carefully pull the venturi piece slightly out of the bottom of the basket. You do not need to remove it, just pull it out enough to access the orifice on the side.



33. This is not an exact science, as many components affect how well the venturi system will function. If your fuel pressure regulator is unable to maintain low enough fuel pressure at idle, this step will need to be repeated with a slightly larger drill bit. It is better to start small and have to redrill, then to drill too much.

Note: Be careful when drilling as this component is not sold separately and if damaged, will require the purchase of an entire new sending unit/fuel basket. Be careful to make sure the drill bit does not quickly thread into the orifice but is actually drilling. Do not drill through the backside of the piece, it will need to be drilled roughly 10mm deep. You can put a tape mark/stop on your drill bit if desired.

Drill out the orifice to the recommended size shown below:

Pump Size	Recommended Orifice Size	Recommended Drill Bit Size
255lph or 340lph	~0.075"	#49 drill bit = 0.0730", #48 drill bit = 0.076", 5/64 drill bit = 0.0781", 2mm drill bit = 0.0787"

Once drilled, reinstall the venturi orifice piece into the lower fuel basket.

34. Clean off any debris, dirt, and plastic shavings from all fuel basket components.
35. Reassemble the fuel basket assembly with the spring from step #16 and then take the assembled fuel basket over to the vehicle.
36. Replace the basket seal with the newly supplied Viton basket seal and carefully install the fuel basket assembly into the fuel tank. Before fully seating the pump assembly, reconnect the siphon hose from inside the tank. Be careful not to bend the fuel level sensor or pinch/cut the submersible fuel hose on the fuel tank opening.



37. The fuel basket should rest on the bottom of the tank and will need to be compressed a small amount, roughly 5mm, to secure the top hat. With the OE top hat to the fuel tank loosely install the (6) M5 bolts and torque to **22 in/lbs** in a crisscross pattern. Connect the new chassis side harness connector to the Z1 top hat.



38. Reconnect the OE fuel line that was removed in step #10 to the new quick disconnect fitting installed in the top hat.

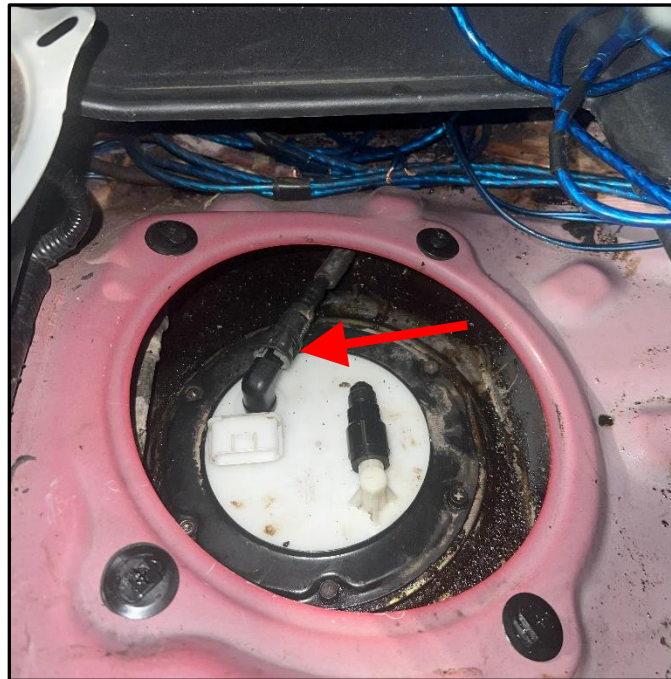

Fuel Damper Install:

1. If not completed in the Fuel Pump Upgrade and Fuel Pressure Regulator Delete section above, it is time to release fuel pressure. There are a couple ways to do this:
 - a. If you have access to CONSULT:
 - i. Turn the ignition switch ON.
 - ii. Perform "FUEL PRESSURE RELEASE" in "WORK SUPPORT" mode with CONSULT.
 - iii. Start engine.
 - iv. Wait for the engine to run out of fuel and stall.
 - v. Crank engine over two or three times to release remaining fuel pressure.
 - vi. Turn ignition switch OFF
 - b. If you do not have access to CONSULT:
 - i. Disconnect the electrical connector on the top of the fuel tank.
 - ii. Start engine.
 - iii. Wait for the engine to run out of fuel and stall.
 - iv. Crank engine over two or three times to release remaining fuel pressure.
 - v. Turn ignition switch OFF

Note: If swapping injectors, please reference Nissan Field Service Manual for upper/lower plenum, fuel rail and injector removal. Make sure to load an updated tune file prior to starting the vehicle.

1. Open engine hood and secure with prop rod.
2. Place a rag around the fuel damper connected to the fuel feed hose at the back left of the engine bay (circled at right). While applying light pressure to the damper, loosen the (2) bolts securing it to vehicle.
3. When separating the fuel feed hose with damper, disconnecting from the fuel connection hose under the floor is required.
4. Locate the fuel feed hose by passenger exhaust manifold on the frame and remove protective cap.
5. Using a fuel line quick disconnect tool and with a container or spill pan to collect residual fuel, disconnect line fuel feed damper line.
6. Pull damper with o-ring and fuel line from engine bay and set to the side.

Note: Cap off or cover open fuel lines after disconnecting or removal to prevent debris or moisture from entering the fuel system.



- Using the supplied Z1 damper with attached sealing o-ring and (2) Allen head bolts, install in the OE RH damper location with the male flares pointing towards the firewall and torque to **74in/lbs.**



Fuel Pressure Regulator Install:

- Your Z1 Fuel Pressure Regulator will arrive mostly assembled with the exception of orb fittings/plugs for the fuel lines.
- Below shows the regulator and what each component/port is used for:

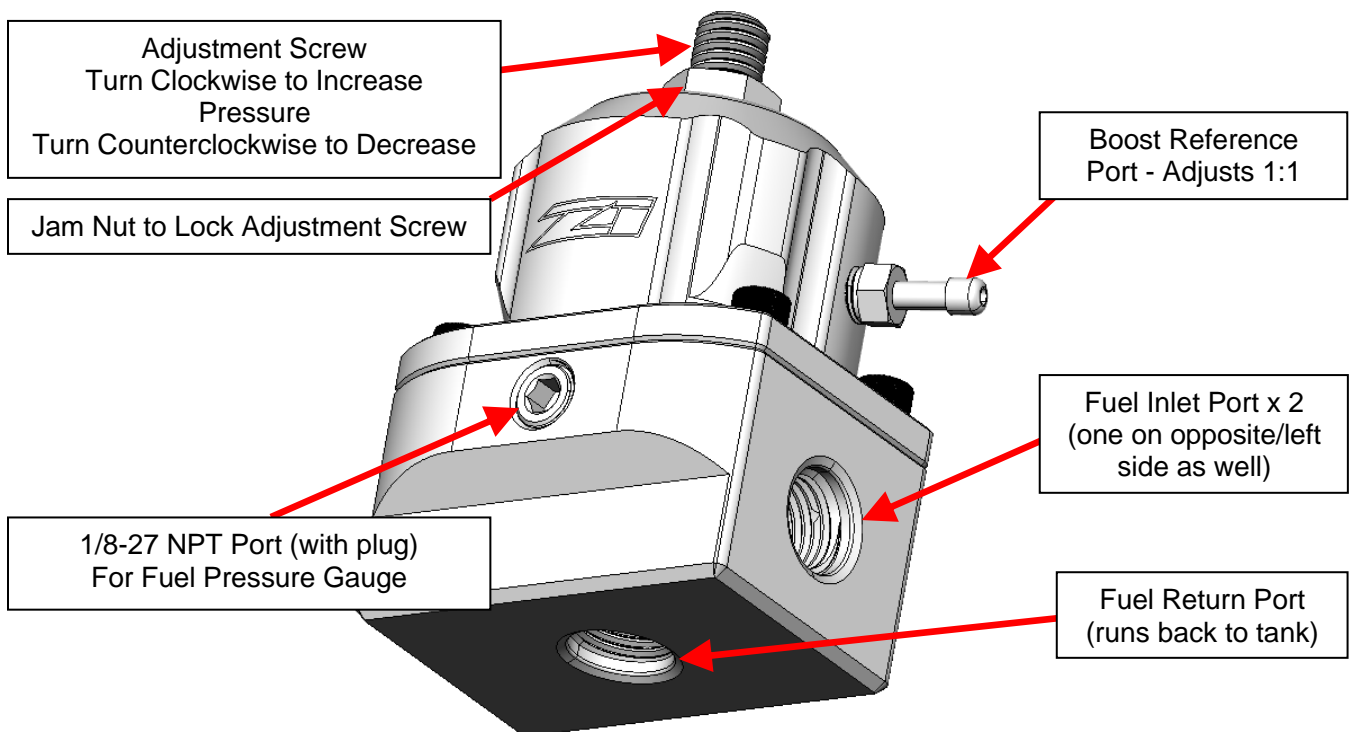

- Install the (3) 6AN ORB fittings on the bottom and sides of the regulator. Remove the plug on the front and with the correct fuel pervious thread sealant, install the provided fuel pressure gauge.

4. Remove the passenger side plastic battery cover and cowl trim piece. Then remove the white plastic clip on the back of the firewall, shown below with a yellow arrow. Use pliers to pinch the nubs and push towards the rear of the vehicle to remove it from the firewall.

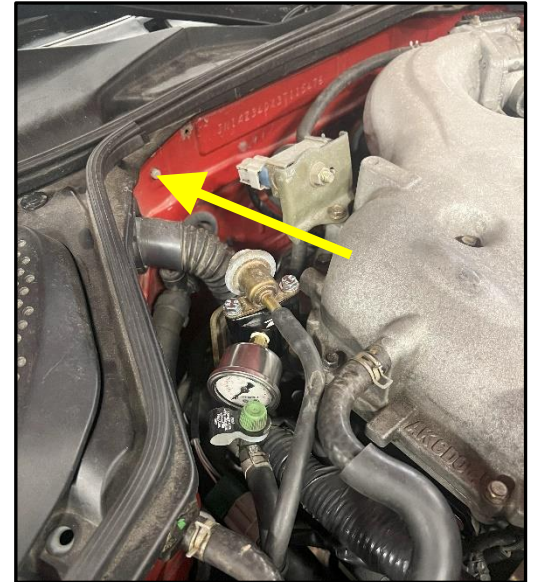
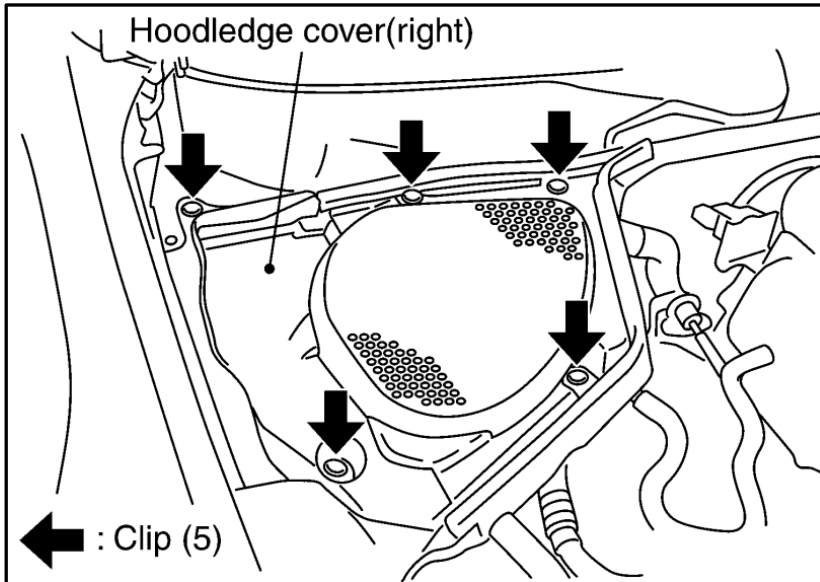

5. Remove the universal bracket that comes on the regulator. Retain the hardware.
6. Attach the larger piece of the other provided bracket onto the rear of the regulator with the bolts removed in the previous step. The orientation of the bracket should be bolted as indicated below.

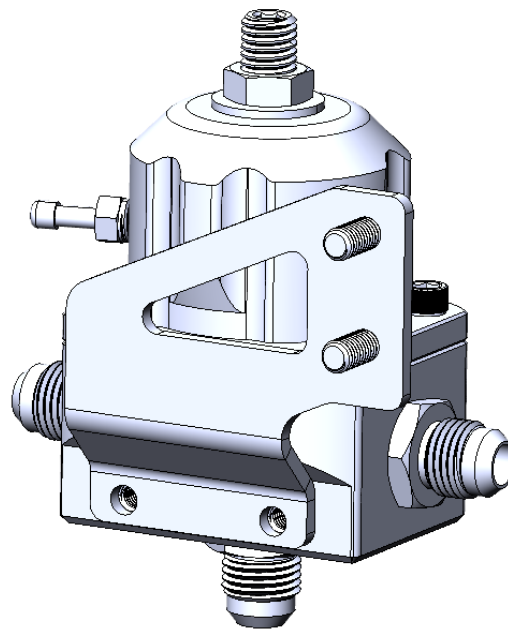

7. Install the (2) rubber bonded washers onto the PEM studs.

8. Install the FPR bracket's studs into the (2) holes on the firewall where the plastic clip was removed from in step # 4. Then place the other L-shaped bracket onto the studs and secure with the provided flange nuts.

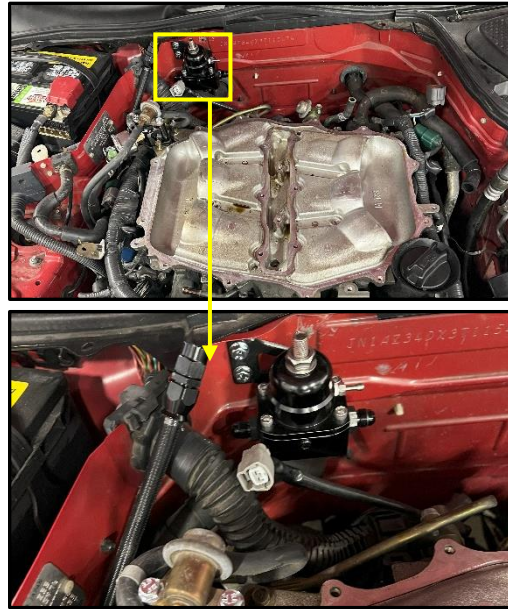

Note: The image above shows a sample bracket that uses two bolts instead of PEM studs installed on the bracket.

9. Consult your tuner on whether they would like to use boost reference for the regulator.
10. If you need boost reference, locate the 4mm silicone vacuum hose. There is an unused port on the OE upper intake plenum that is capped off. Remove the cap and run the vacuum hose from the FPR to the port on front corner of the upper plenum. Secure with the two provided small clamps.

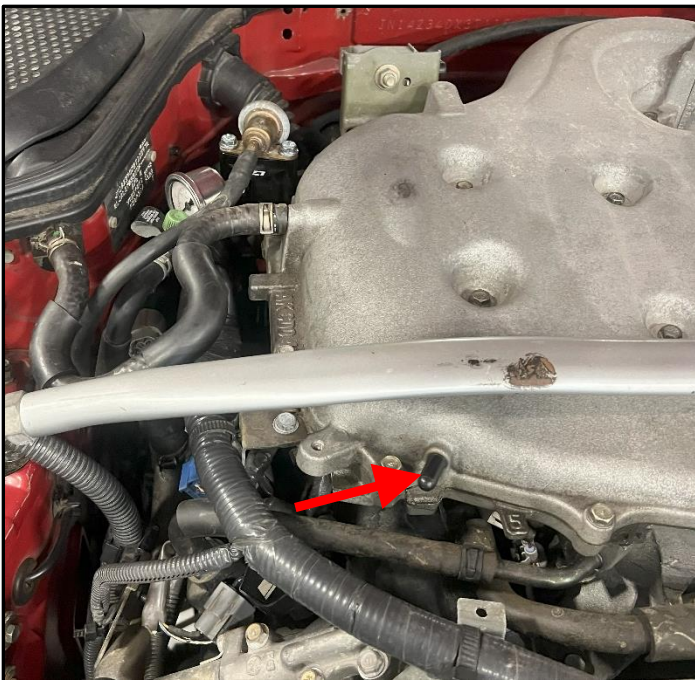

11. Follow the rest of the instructions for the fuel lines to properly plumb the Z1 regulator and damper.

Fuel Lines and Fuel Filter:

1. With the Z1 fuel return kit, the factory fuel feed line will function as the return line back to the tank. The feed hardline will need to be disconnected from the rubber feed hose connected to the damper in the engine bay. The OE rubber hose connects to the OE hardline on the inside of the passenger side frame rail with a quick connector. If not removed previously, remove the plastic cover shown with a red arrow below. Then separate the lines just like the one from step #4 on page 19.

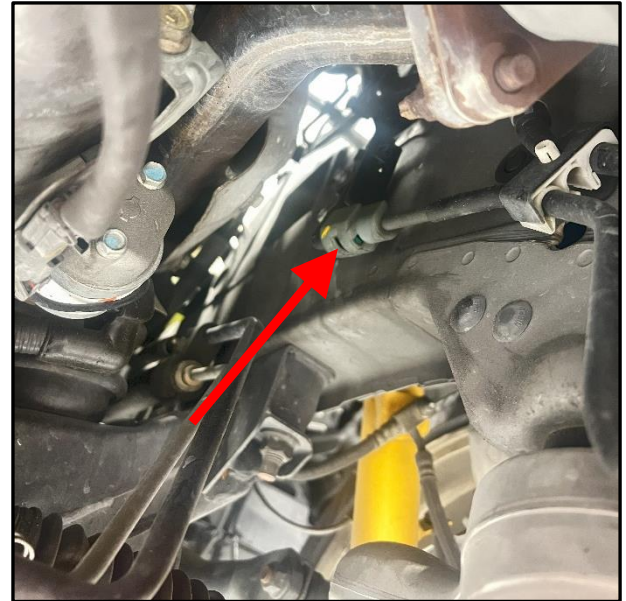
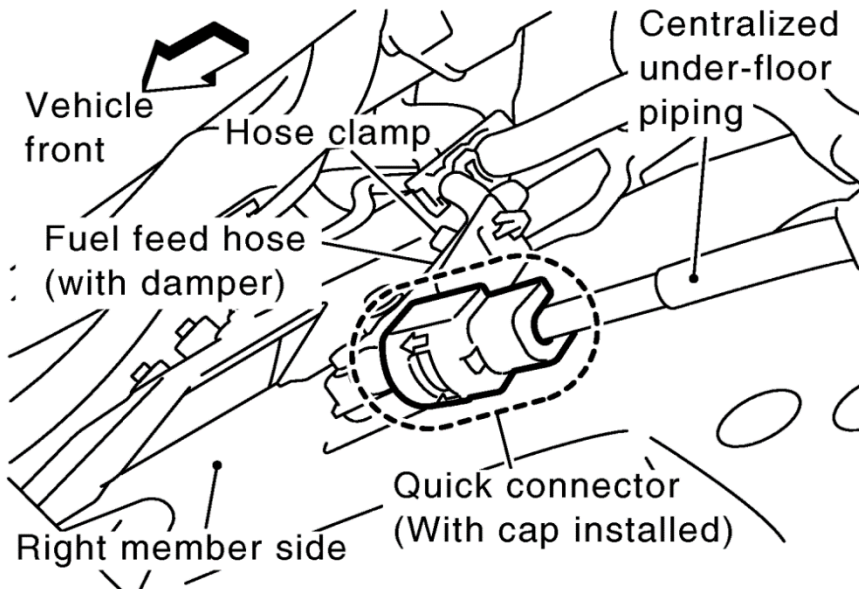

2. If you have not performed the previous installations of the regulator delete, fuel pump upgrade or damper install, be sure to relieve fuel and fuel pressure from the lines. There are a couple ways to do this:
 - c. If you have access to CONSULT:
 - i. Turn ignition switch ON.
 - ii. Perform "FUEL PRESSURE RELEASE" in "WORK SUPPORT" mode with CONSULT.
 - iii. Start engine.
 - iv. Wait for engine to run out of fuel and stall.
 - v. Crank engine over two or three times to release remaining fuel pressure.
 - vi. Turn ignition switch OFF
 - d. If you do not have access to CONSULT:
 - i. Disconnect the electrical connector on the top of the fuel tank.
 - ii. Start engine.
 - iii. Wait for engine to run out of fuel and stall.
 - iv. Crank engine over two or three times to release remaining fuel pressure.
 - v. Turn ignition switch OFF

3. Remove the release piece from the OE hardline if it did not come off with the rubber hose. Install the provided 5/16 (smaller) billet quick disconnect threaded adapter onto the OE hardline. It is a two-part adapter; the smaller grooved piece will slide over the lip on the OE hardline and then the larger piece will thread onto the smaller.



4. Prior to installing the fuel damper outlet to FPR Inlet hose, locate the (2) provided Allen pan head bolts and install in the circled locations indicated on the right.
5. Locate the fuel line kit. The kit contains (7) different lines. Each line will be bagged individually with a part number on the bag, do not separate the line from its bag until you are ready to install it. These lines have a PTFE core that if kinked cannot be un-kinked. Be careful when routing and maneuvering these lines, if you kink one you will need to order a replacement. DO NOT overtighten the fuel line fittings or use any additional sealant on the lines.



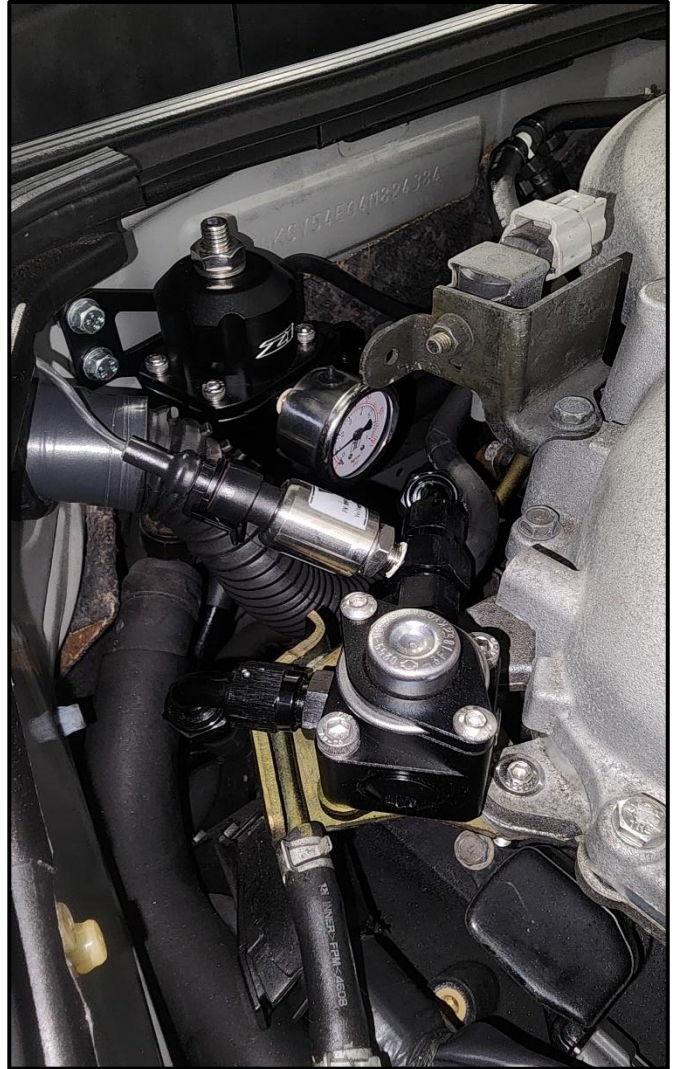

Note: Refer to the diagram below as reference to how each one will be run.
The chart below details all (7) provided fuel lines and connections.

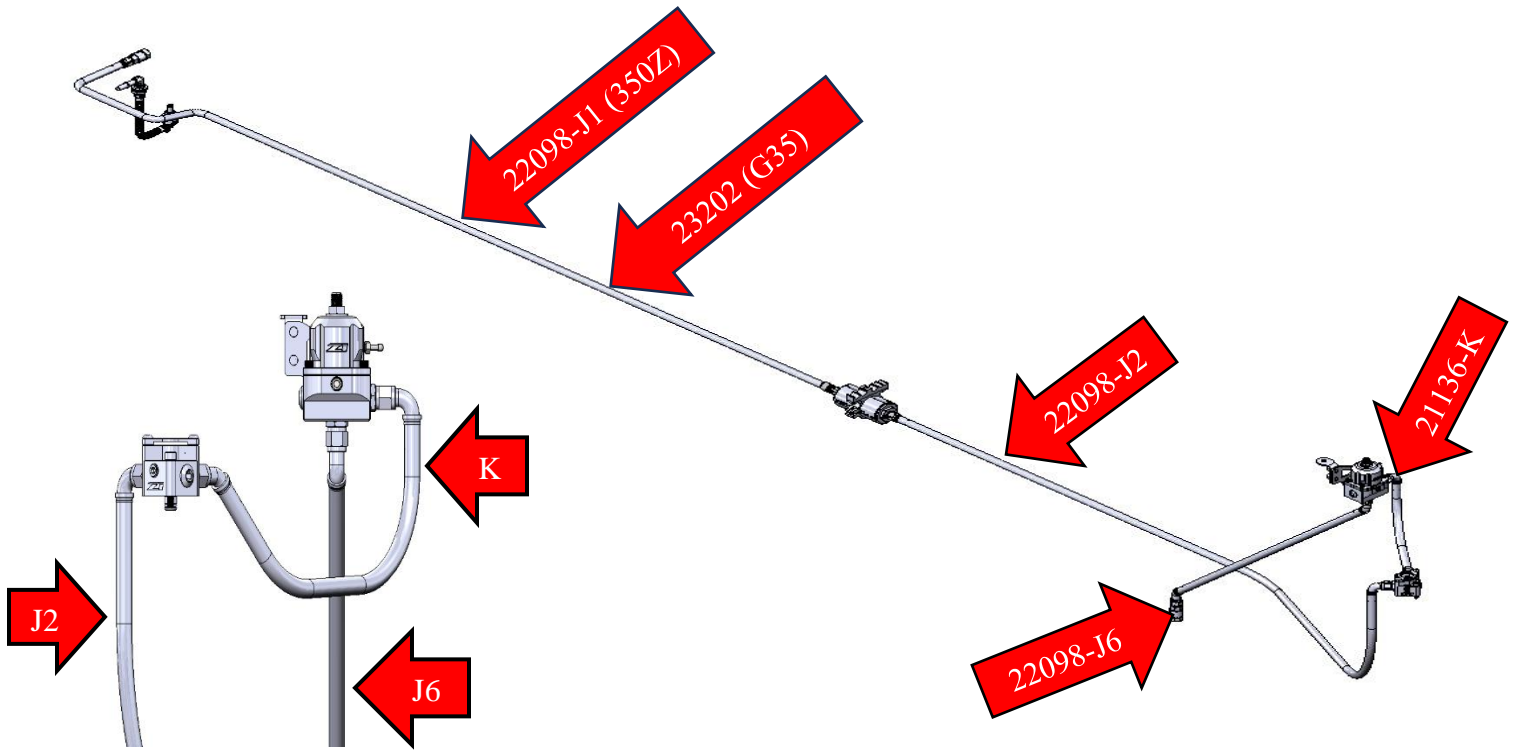

PN	Description	Fitting #1	Fitting #2
22098-J1 (350Z)	Top Hat Outlet -> Fuel Filter Inlet	Straight – Top Hat Outlet	Straight – Fuel Filter Inlet
23202 (G35)	Top Hat Outlet -> Fuel Filter Inlet	Straight – Top Hat Outlet	Straight – Fuel Filter Inlet
22098-J2	Fuel Filter Outlet -> Fuel Damper Inlet	Straight – Fuel Filter Outlet	90° – Damper Inlet
21136-K	Fuel Damper Outlet -> FPR Inlet	45° – Fuel Damper Outlet	90° – FPR Inlet
22098-J6	FPR Return Port -> Factory Feed	45° – FPR Return Port	45° – Factory Feed

6. From the underside of the car, push the pump feed line (22098-J1) up between the chassis and the front of the fuel tank towards the fuel pump top hat.

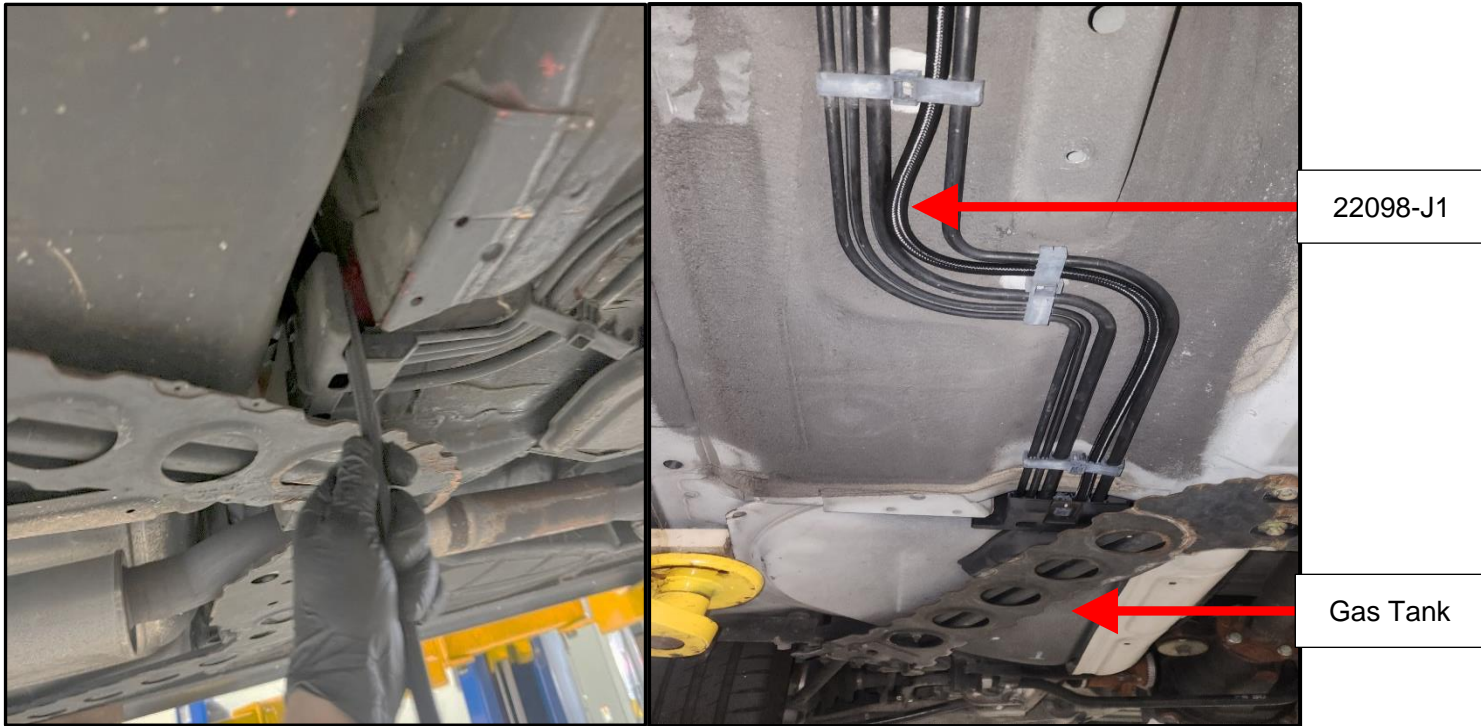

7. Inside the vehicle, grab the feed line, pull it towards the top hat, do not install it yet.
8. On the underside of the vehicle there will be several OE hardline retaining clips (shown below). The 4th clip from the rear will be removed and replaced with the Z1 external fuel filter mounting bracket. Remove the 4th clip (shown below with an arrow) from the vehicle by pulling down.



9. Locate the fuel filter and mounting bracket.
10. Position the fuel line clip piece of the bracket onto the stud where the OE fuel line clip was removed from in step #7. Secure the Z1 fuel line clip with the supplied flange nut.

11. Position the Z1 fuel filter into the clamp piece of the bracket and tighten clamp with the supplied socket head bolt. Then secure the clamp to the fuel line clip with the (2) supplied flange bolts. Make sure the **INLET** is pointing towards the **REAR** of the vehicle.



12. Route the rest of the feed line along the factory hard fuel line against the passenger side frame rail (shown below). Route the Z1 fuel line through the remaining open slots in the brackets.
13. Secure the pump feed line to the **inlet** of the fuel filter. The filter is marked with "**IN**" and "**OUT**" on each fitting.



14. Install the filter outlet fuel line (22098-J2) onto the outlet of the fuel filter and route the rest of the line along the factory hard fuel lines against the passenger side frame rail towards the engine bay.

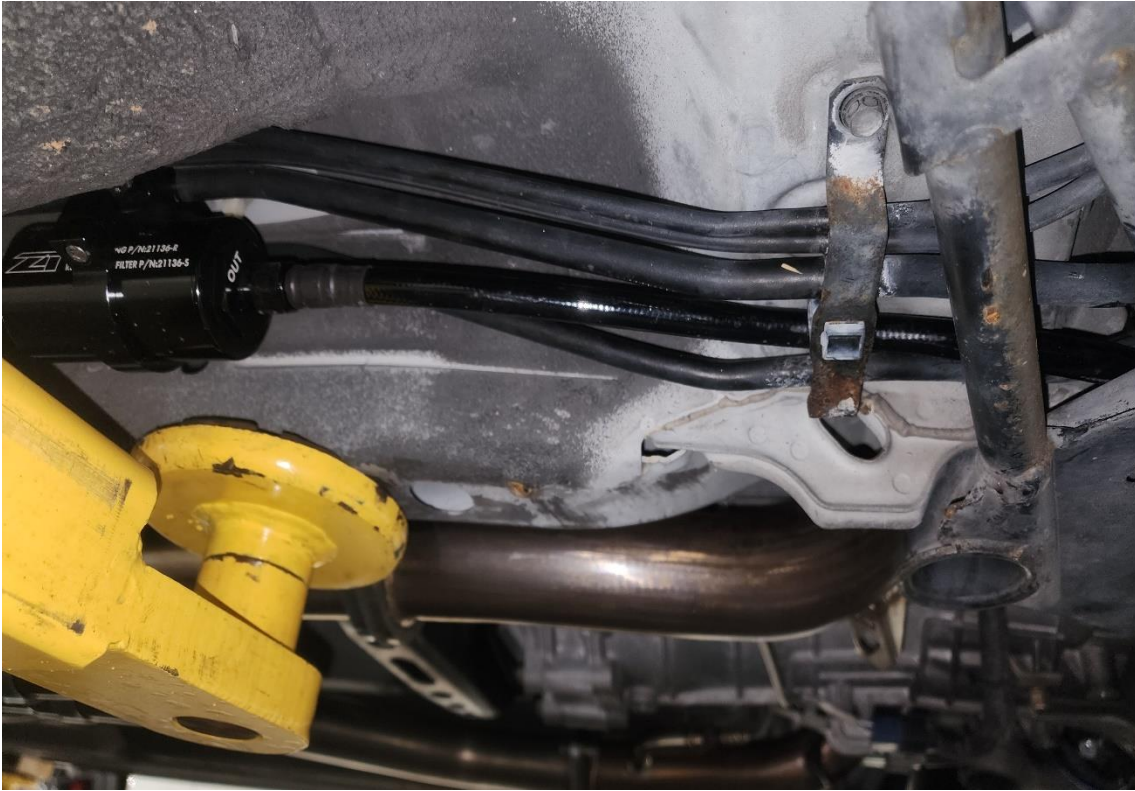

15. Once passed the frame rail, route the feed line over the suspension arm and up towards the engine.
16. Using the supplied cushion loop clamp (circled below), on the inside of the passenger side frame rail, secure the feed line to the bolt on the OE hard line bracket.



17. Route the feed line towards the rear of the engine .

Note: For vehicles equipped with long tube headers, **fire sleeve** or **heat wrap** is recommended to prevent increased fuel temperature and premature wear to the fuel lines.

18. Return to the inside the vehicle and thread the new Z1 AN feed line onto the adapter fitting on the pump side of the OE top hat.



19. Connect the OE hard fuel line (what used to be the stock feed line) to the return side of the Z1 top hat.
20. Reinstall all other components removed in the previous steps (intakes, cowl panel, trim pieces, etc.).
21. Check the vehicle for loose tools/items.
22. Reconnect the negative battery cable.
23. Prime the fuel system by turning the key to the on position, but do not start the vehicle.
24. Check the fuel pressure gauge to see if you have fuel pressure and check for leaks. This may take several priming sequences for pressure to build up.
25. If you installed new larger injectors, contact your tuner for an updated tune before starting your engine.
26. Start vehicle.
27. Check for leaks again.
28. Quickly monitor the fuel pressure gauge and adjust the Z1 regulator to the desired fuel pressure. Rotating the adjustment screw clockwise will increase pressure, while rotating it counterclockwise will decrease pressure. Most OEM Nissan fuel systems are set to 52 PSI. The Z1 regulator can adjust pressure from 40-75psi.
29. Once you confirm the base fuel pressure is correct, tighten the jam nut on the adjustment screw.

END

Additional Technical Support:

Contact Z1 Motorsports at info@z1motorsports.com
Or call 770-838-7777 between 9am and 6pm ET