

Z1 DOOR STOPPER REBUILD KIT INSTALLATION MANUAL

**PROLOGUE:**

Study these instructions completely before proceeding to assembly. The installer must have a thorough knowledge of automotive systems operation. If unfamiliar with any of the concepts outlined in this instruction, we recommend the installation be completed by a qualified professional.

WARNING!

Extreme caution should be taken when performing maintenance or performance upgrades to your vehicle. Please observe and abide by any Warning or Caution labels placed on the various components and tools used when servicing your vehicle. If you have any questions regarding installation or the various components included with the Z1 Motorsports Door Stopper Rebuild Kit, consult with a Professional Mechanic, or contact Z1 Motorsports for more information.

PARTS INCLUDED:

Item	Quantity	Description
1	4	Plastic Guide
2	4	Rubber Bushing

TOOLS REQUIRED:

- Ratchet
- Ratchet Extension(s)
- Assorted Metric Wrenches
- Assorted Metric Sockets
- Pliers
- Silicone Spray/Equivalent Lubricant
- Trim Removal Tool

SAFETY REQUIREMENTS:

- Always wear safety glasses and any necessary protective garments. If using any fluids, chemicals, or solvents, a respirator is recommended.
- Always turn the ignition to the OFF position and disconnect the NEGATIVE battery terminal.
- Always use properly rated jack stands when working under your vehicle.
- Always keep limbs and parts away from moving drivetrain parts.
- Only operate drivetrain in safe space and well-ventilated areas.

BEFORE YOU BEGIN:

Remove contents from the Z1 Motorsports Door Stopper Rebuild Kit and verify that ALL necessary hardware is present.

Refer to the Table of Contents on the next page for your applicable vehicle to remove the Door Panel or for Check Link Disassembly.

TABLE OF CONTENTS

350Z.....	4
G35 COUPE	9
G35 SEDAN.....	13
370Z.....	22
G37 COUPE	28
G37 SEDAN.....	33
D40 FRONTIER	43
N50 XTERRA.....	51
BOLTED CHECK LINK	60
TAB CHECK LINK	64

350Z

1. Place the transmission in Park position (or in Reverse gear if equipped with a manual transmission). Apply the parking brake.
2. Open the Driver Side Door.
3. Pull the Door Release Handle and remove the small Trim Piece behind it with a Trim Removal Tool. *Figure 1.*



Figure 1

4. Remove the (1) one 10mm Bolt hidden behind the Trim Piece that was just removed. *Figure 2.*

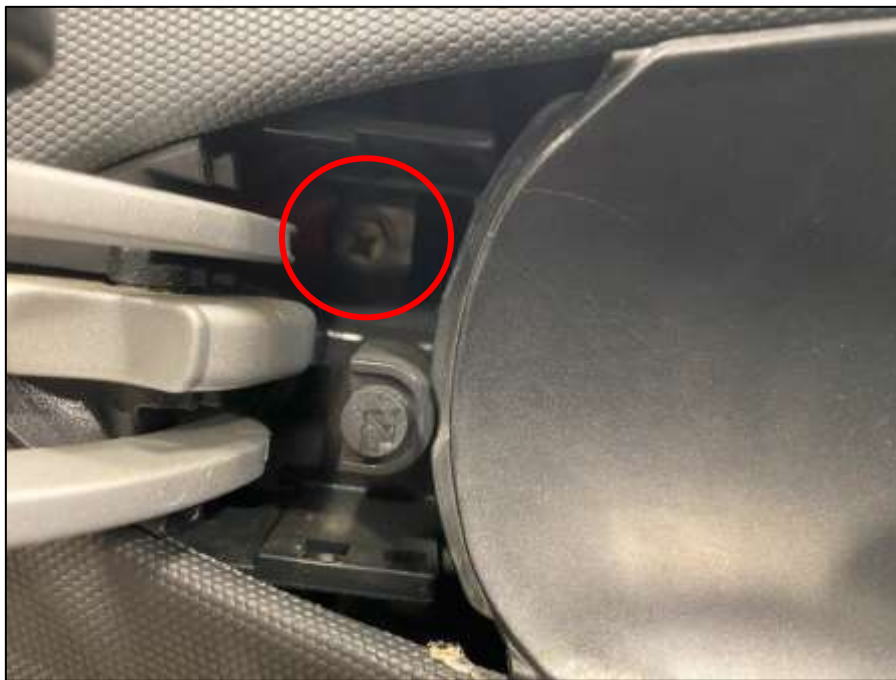

Figure 2

5. Remove the (1) one screw in the Door Control Panel. *Figure 3.*

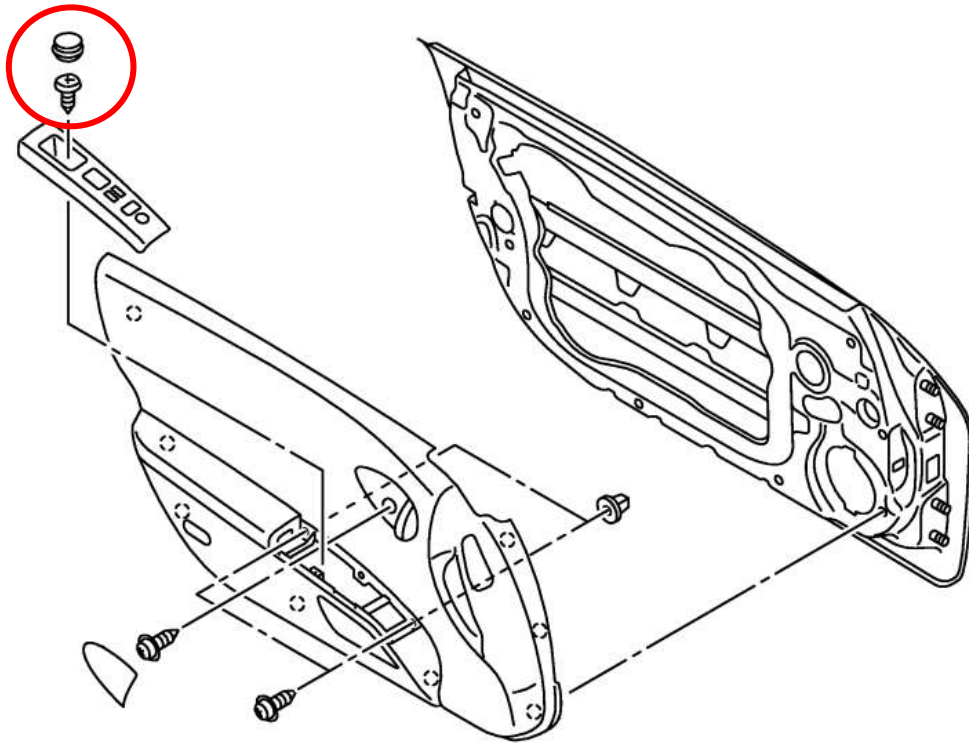

Figure 3

6. Pry up the Door Control Panel using a Trim Removal Tool. *Figure 4.*

7. Disconnect the (2) two Door Control Panel connectors. Circled below in *Figure 4.*



Figure 4

8. Remove the (2) two 10mm Bolts securing the Door Panel to the Door. They may spin without removing. If this happens, apply pressure behind the head of the Bolt by pulling the Door Panel outward. *Figure 5.*



Figure 5

9. Use a Trim Removal Tool to pry the Door Panel away from the Door. Support the Door Panel from falling once it is released. *Figure 6.*



Figure 6

10. Disconnect the Door Latch and Lock cables from the Door Panel. They will easily pop out. *Figure 7.*



Figure 7

11. Remove the Door Panel from the vehicle and set aside.

12. Remove the (3) three bolts securing the Speaker to the Door Panel. *Figure 8.*

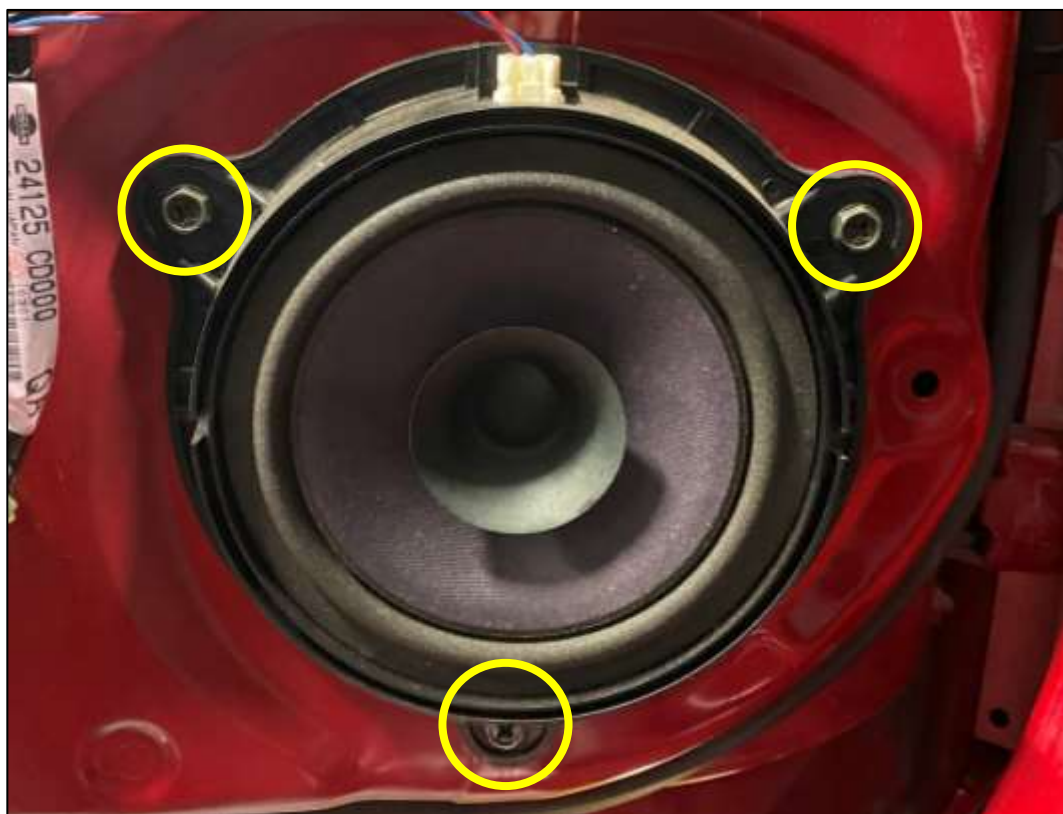

Figure 8

13. Remove the Speaker from the Door. You can optionally disconnect the Connector to the Speaker or just let it hang.

14. Open the door as wide as you can. Remove the (3) three Bolts in the Door securing the Check Link. *Figure 9.*



Figure 9

15. Pull the Door Stopper/Hinge Assembly through the Speaker Hole to remove it.
16. Continue to the [TAB CHECK LINK](#) section for Check Link disassembly and Door Stopper Installation.
17. Repeat Steps 3-16 for the other side of the vehicle.
18. Repeat Steps 3-15 in reverse order for reinstallation of the Check Links and Door Panels.

G35 COUPE

1. Place the transmission in Park position (or in Reverse gear if equipped with a manual transmission). Apply the parking brake.
2. Open the Driver Side Door.
3. Pull the Door Release Handle and remove the small Trim Piece behind it with a Trim Removal Tool. *Figure 10.*

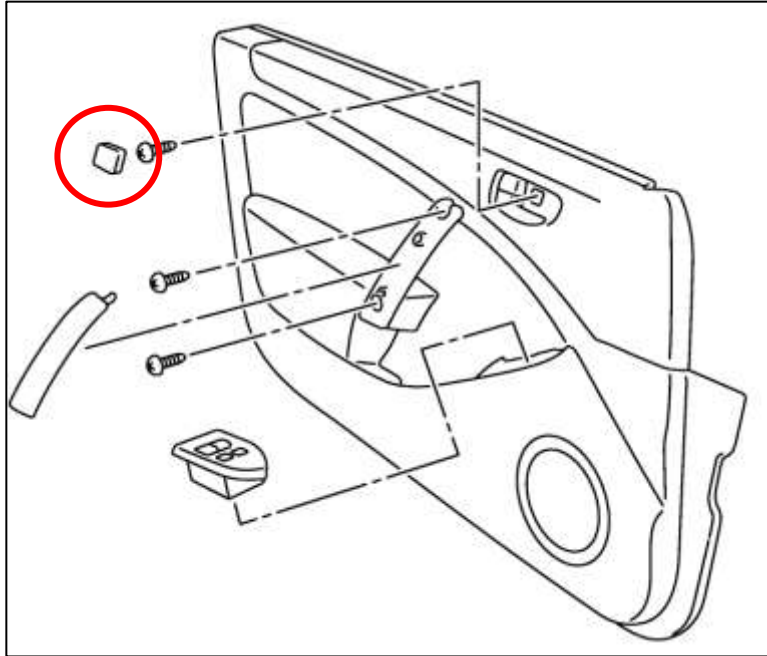

Figure 10

4. Remove the (1) one 10mm Bolt hidden behind the Trim Piece that was just removed. *Figure 11.*

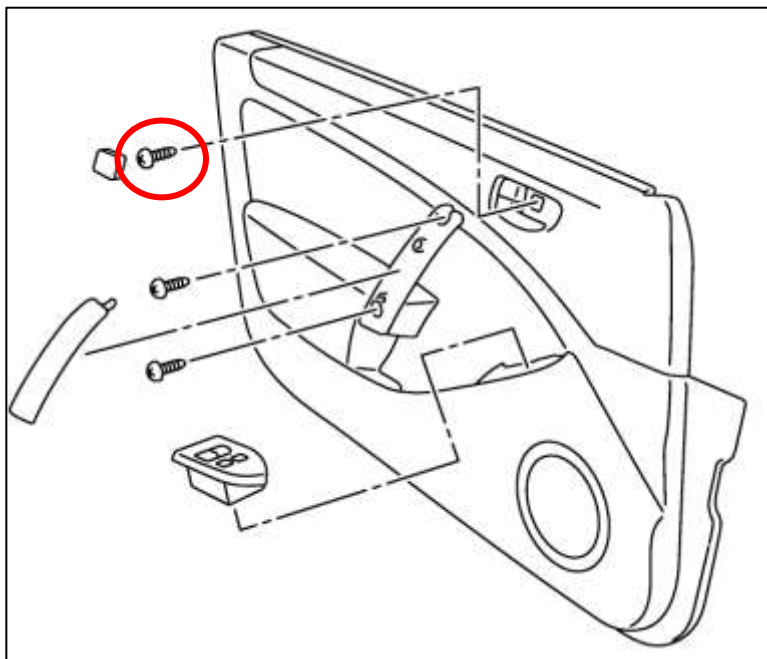

Figure 11

5. Pry up the Door Control Panel using a Trim Removal Tool. *Figure 12.*

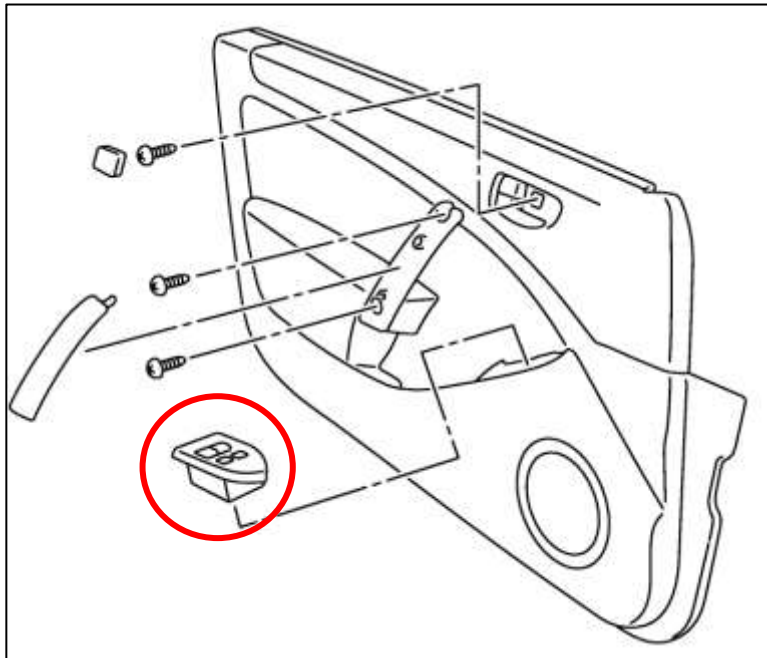

Figure 12

6. Disconnect the Door Control Panel connector and set the Control Panel aside.

7. Remove the Handle Trim Piece with a Trim Removal tool. *Figure 13.*

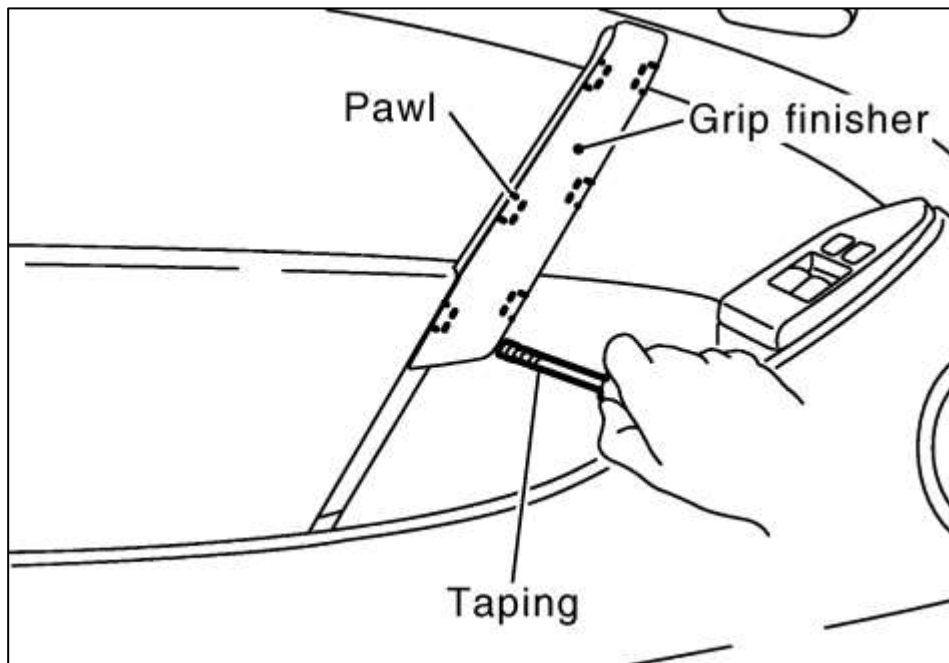

Figure 13

8. Remove the (2) two 10mm Bolts securing the Door Panel to the Door. *Figure 14.*

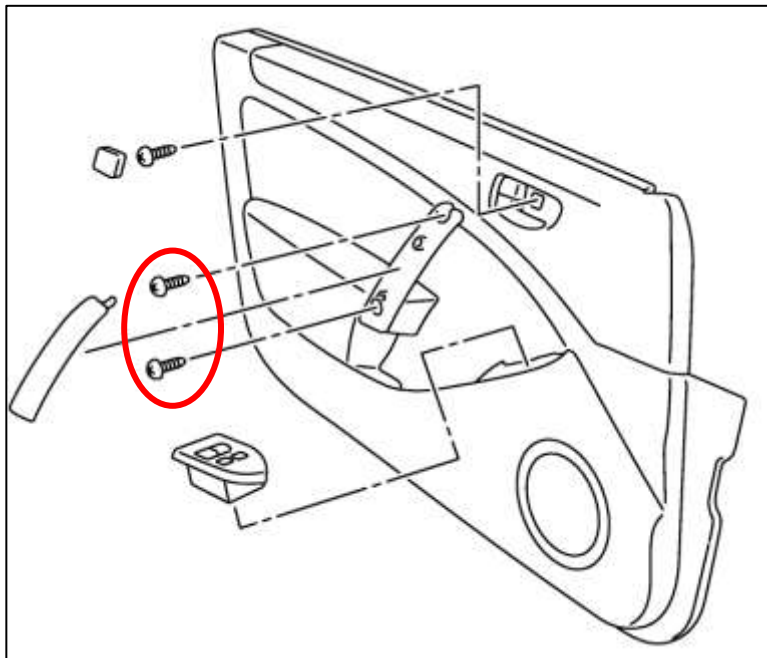

Figure 14

9. Use a Trim Removal Tool to pry the Door Panel away from the Door. Support the Door Panel from falling once it is released.

10. Disconnect the Door Latch and Lock cables from the Door Panel. They will easily pop out. *Figure 15.*

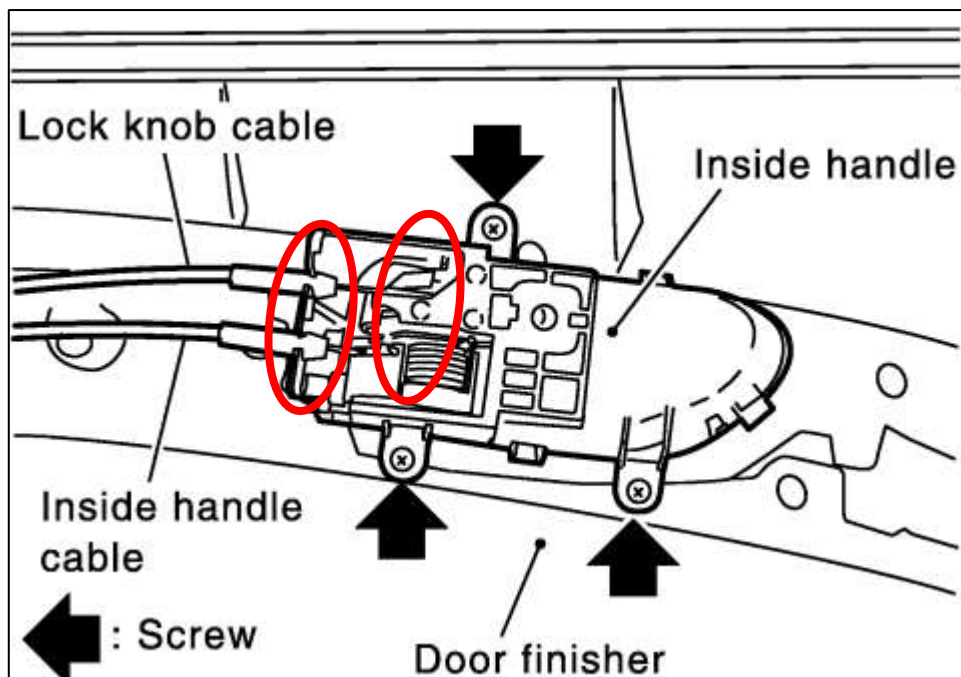

Figure 15

11. Remove the Door Panel from the vehicle and set aside.

12. Remove the (3) three bolts securing the Speaker to the Door Panel. *Figure 16.*

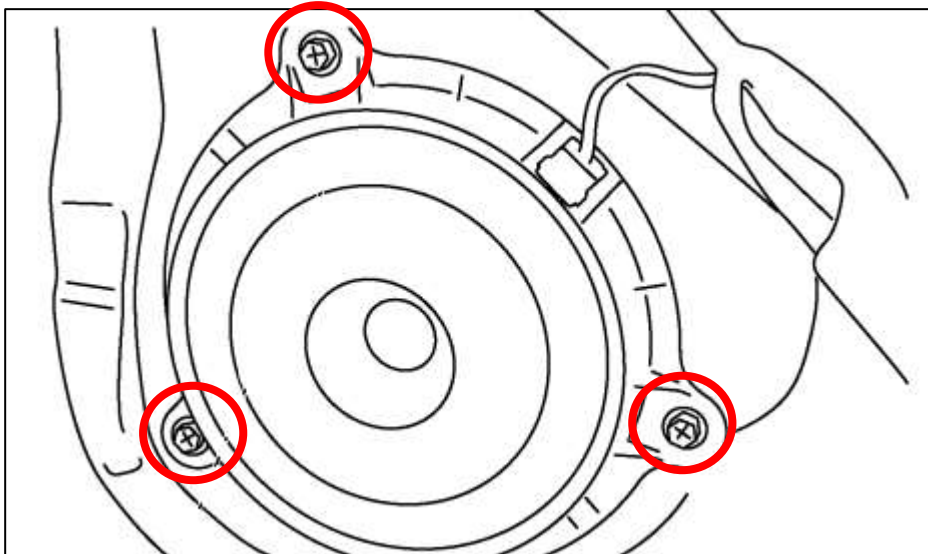

Figure 16

13. Remove the Speaker from the Door. You can optionally disconnect the Connector to the Speaker or just let it hang.

14. Open the door as wide as you can. Remove the (3) three Bolts in the Door securing the Check Link. *Figure 17.*

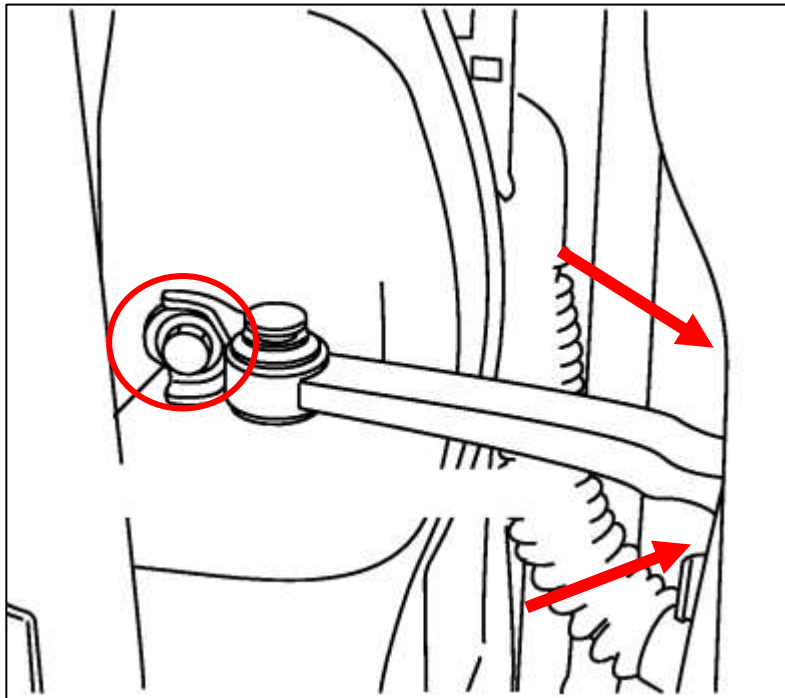

Figure 17

15. Pull the Check Link Assembly through the Speaker Hole to remove it.

16. Continue to the [TAB CHECK LINK](#) section for Check Link disassembly and Door Stopper Installation.

17. Follow *Steps 3-15* in reverse order to reinstall the Check Link and Door Panel.

18. Repeat *Steps 2-17* for the Passenger Side of the vehicle.

G35 SEDAN

FRONT DOOR:

1. Place the transmission in Park position (or in Reverse gear if equipped with a manual transmission). Apply the parking brake.
2. Open the Driver Side Door.
3. Pull the Door Release Handle and remove the small Trim Piece behind it with a Trim Removal Tool. *Figure 18.*

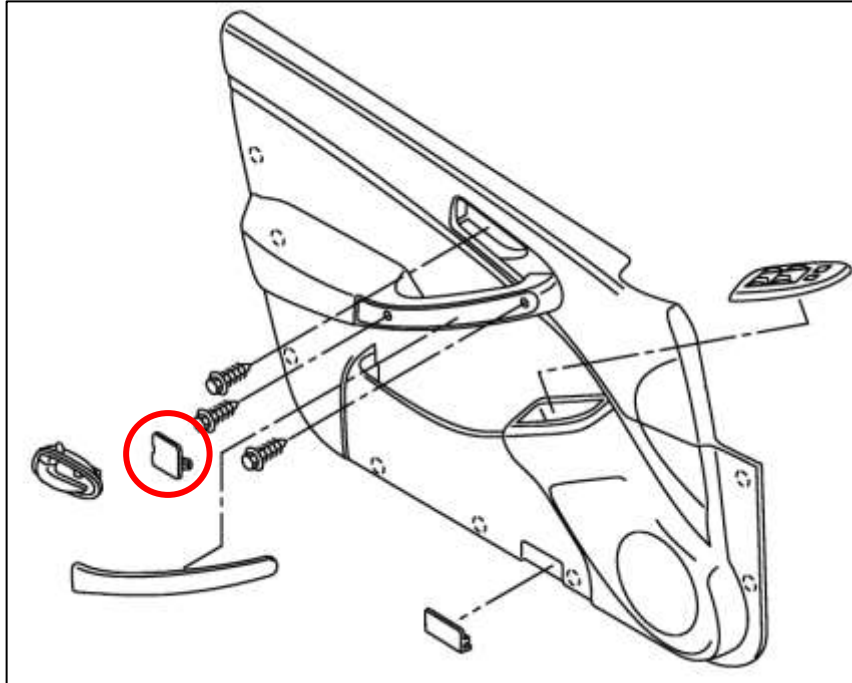

Figure 18

4. Remove the (1) one 10mm Bolt hidden behind the Trim Piece that was just removed. *Figure 19.*

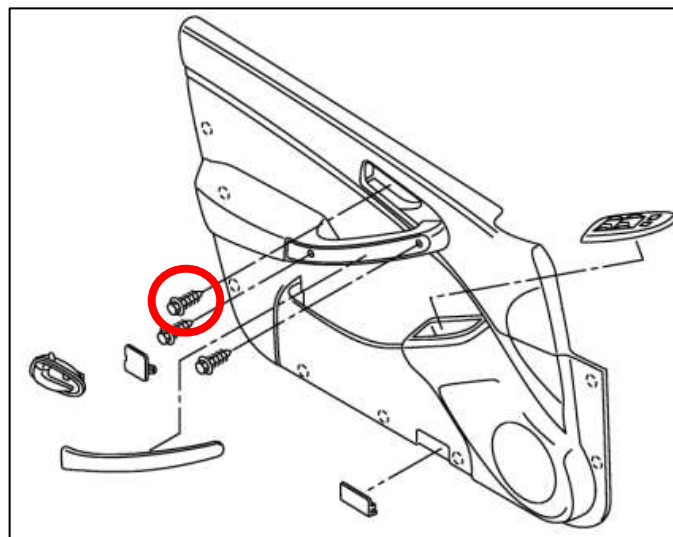

Figure 19

5. Pry up the Door Control Panel using a Trim Removal Tool. *Figure 20.*

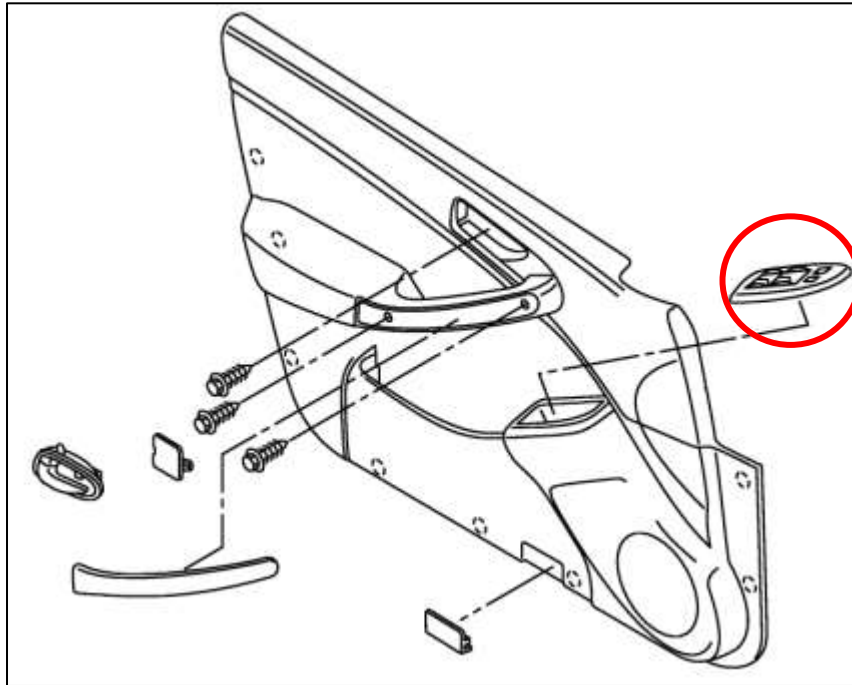

Figure 20

6. Disconnect the Door Control Panel connector and set the Control Panel aside.

7. Remove the Handle Trim Piece with a Trim Removal tool. *Figure 21.*

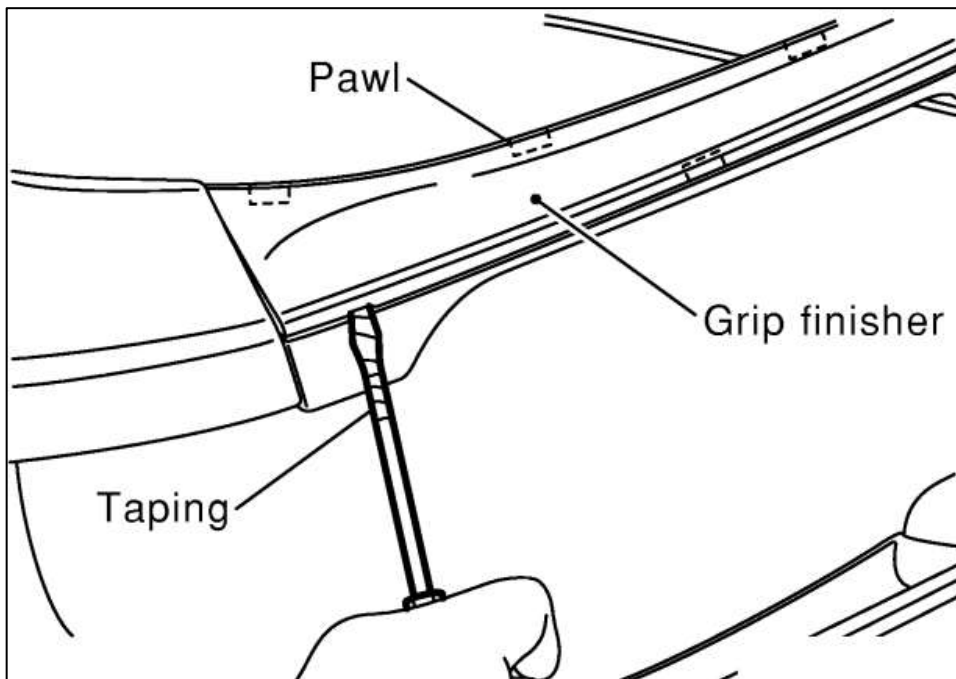

Figure 21

8. Remove the (2) two 10mm Bolts securing the Door Panel to the Door. *Figure 22.*

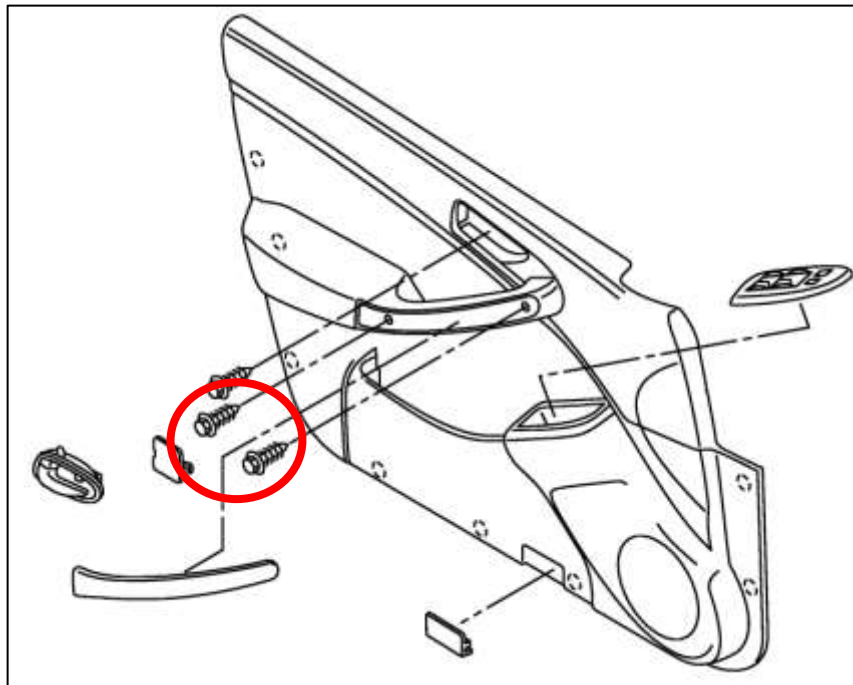

Figure 22

9. Use a Trim Removal Tool to pry the Door Panel away from the Door. Support the Door Panel from falling once it is released.

10. Disconnect the Door Latch and Lock cables from the Door Panel. They will easily pop out. *Figure 23.*

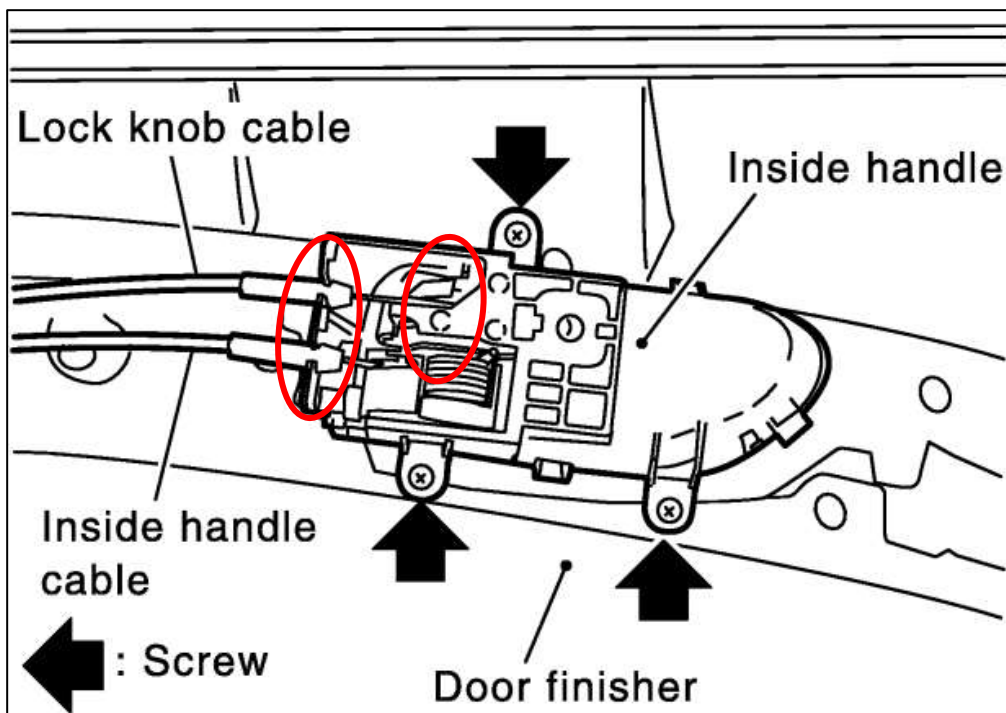

Figure 23

11. Remove the Door Panel from the vehicle and set aside.

12. Remove the (3) three bolts securing the Speaker to the Door Panel. *Figure 24.*

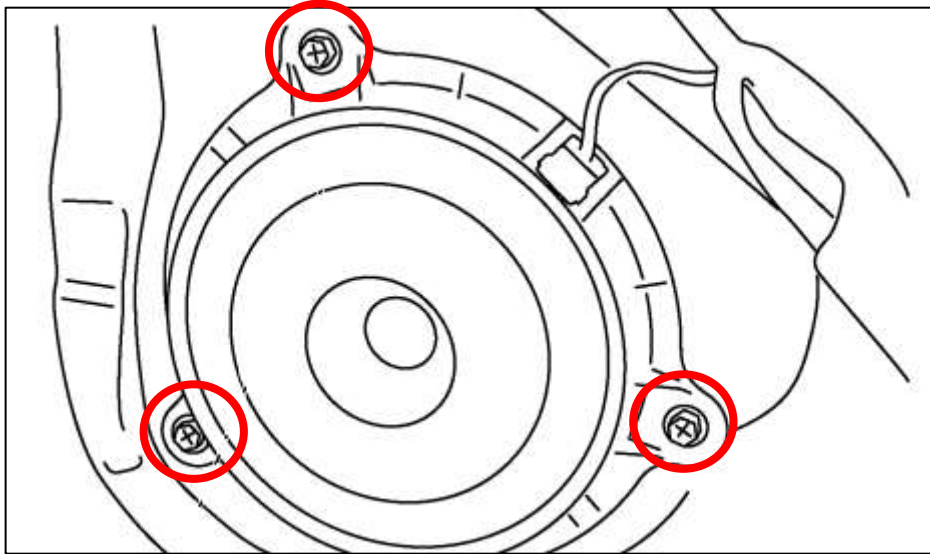

Figure 24

13. Remove the Speaker from the Door. You can optionally disconnect the Connector to the Speaker or just let it hang.

14. Open the door as wide as you can. Remove the (3) three Bolts in the Door securing the Check Link. *Figure 25.*

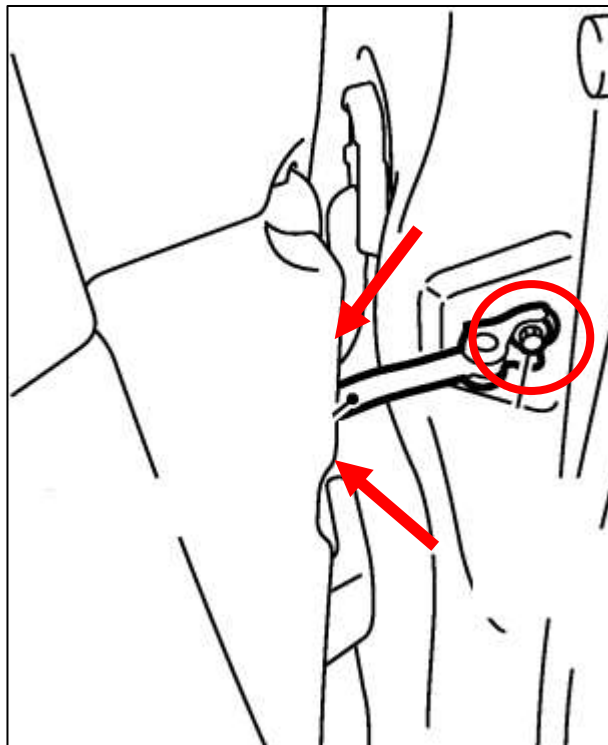

Figure 25

15. Pull the Check Link through the Speaker Hole to remove it.
16. Continue to the [TAB CHECK LINK](#) section for Check Link disassembly and Door Stopper Installation.
17. Follow *Steps 3-15* in reverse order to reinstall the Check Link and Door Panel.
18. Repeat *Steps 2-17* for the Passenger Side of the vehicle.

REAR DOOR:

1. Place the transmission in Park position (or in Reverse gear if equipped with a manual transmission). Apply the parking brake.
2. Open the Driver Side Door.
3. Pull the Door Release Handle and remove the small Trim Piece behind it with a Trim Removal Tool. *Figure 26.*

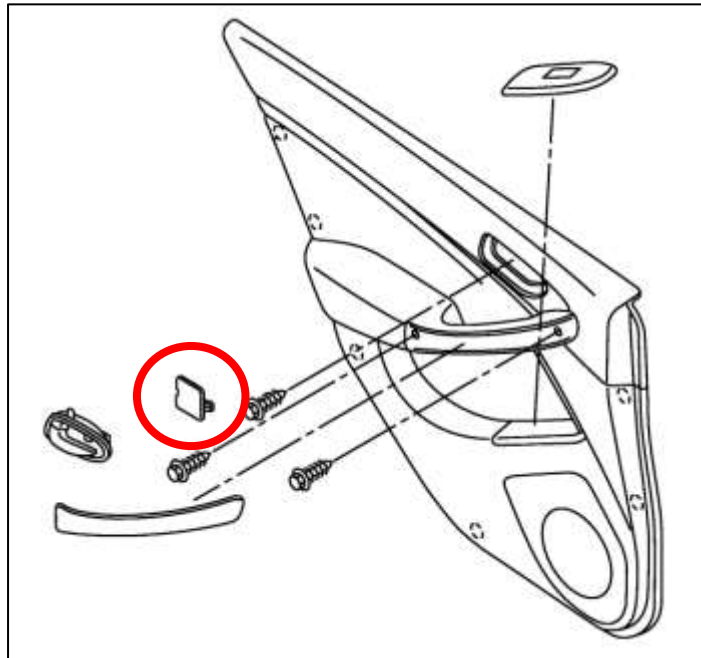

Figure 26

4. Remove the (1) one 10mm Bolt hidden behind the Trim Piece that was just removed. *Figure 27*

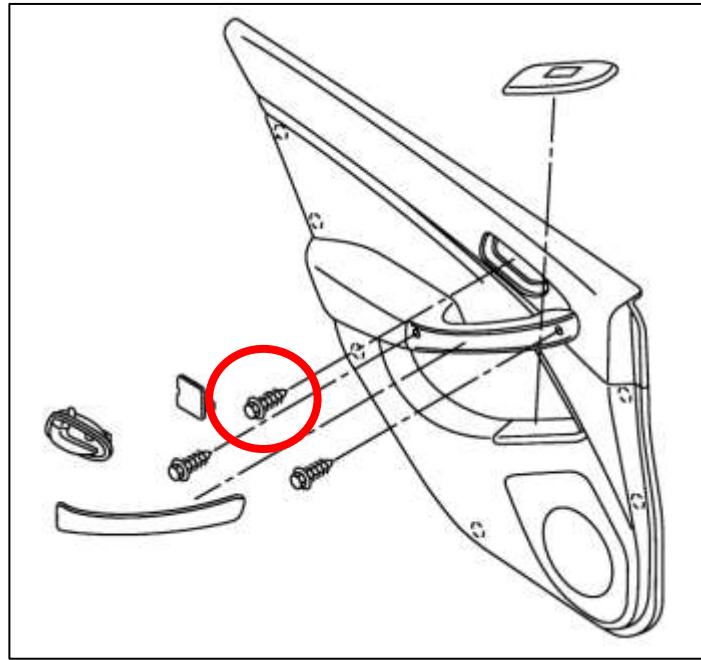

Figure 27

5. Pry up the Door Control Panel using a Trim Removal Tool. *Figure 28*.

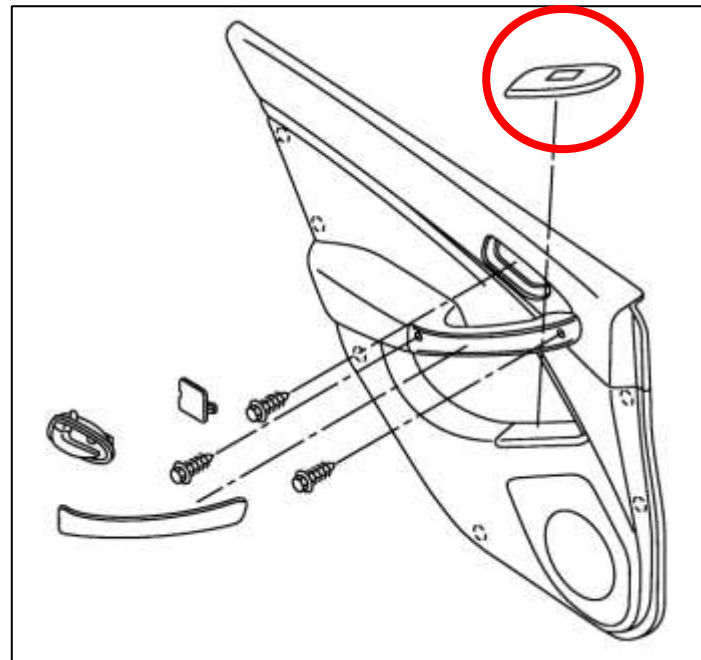

Figure 28

6. Disconnect the Door Control Panel connector and set the Control Panel aside.

7. Remove the Handle Trim Piece with a Trim Removal tool. *Figure 29.*

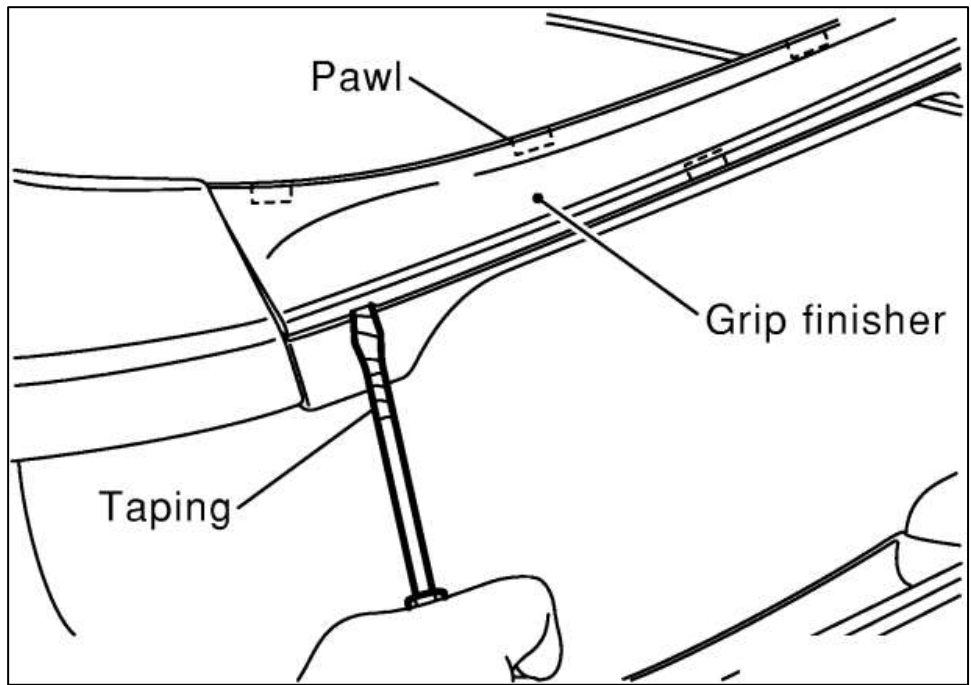

Figure 29

8. Remove the (2) two 10mm Bolts securing the Door Panel to the Door. *Figure 30.*

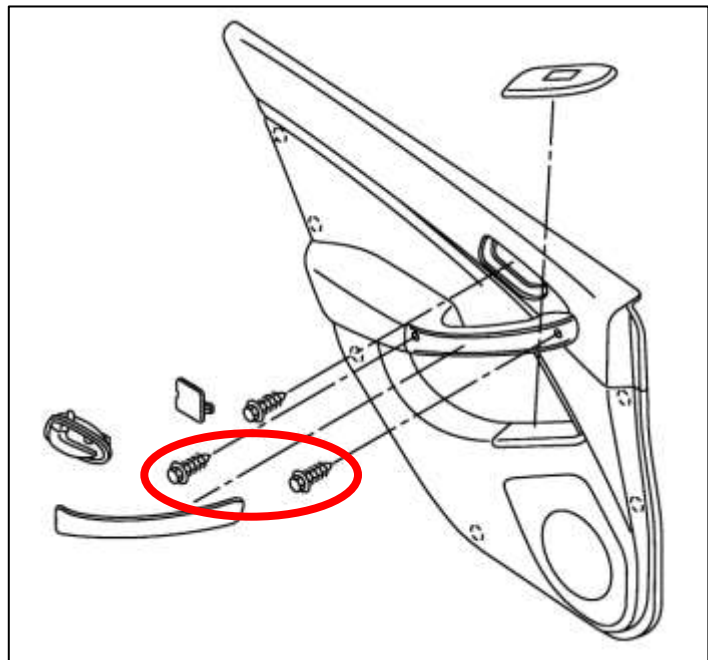

Figure 30

9. Use a Trim Removal Tool to pry the Door Panel away from the Door. Support the Door Panel from falling once it is released.

10. Disconnect the Door Latch and Lock cables from the Door Panel. They will easily pop out. *Figure 31.*

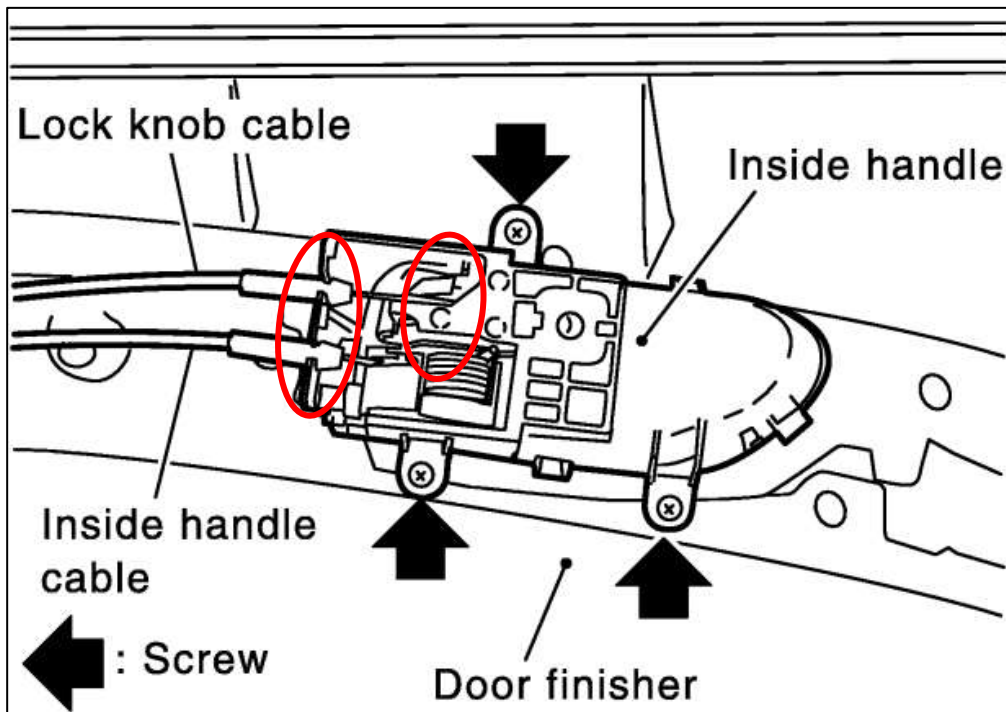

Figure 31

11. Remove the Door Panel from the vehicle and set aside.

12. Remove the (3) three bolts securing the Speaker to the Door Panel. *Figure 32.*

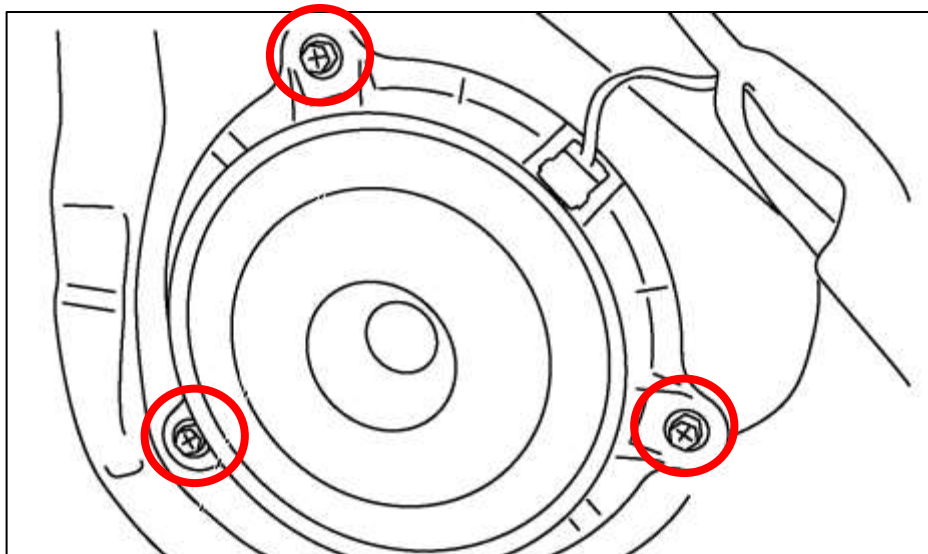

Figure 32

13. Remove the Speaker from the Door. You can optionally disconnect the Connector to the Speaker or just let it hang.

14. Open the door as wide as you can. Remove the (3) three Bolts in the Door securing the Check Link. *Figure 33.*

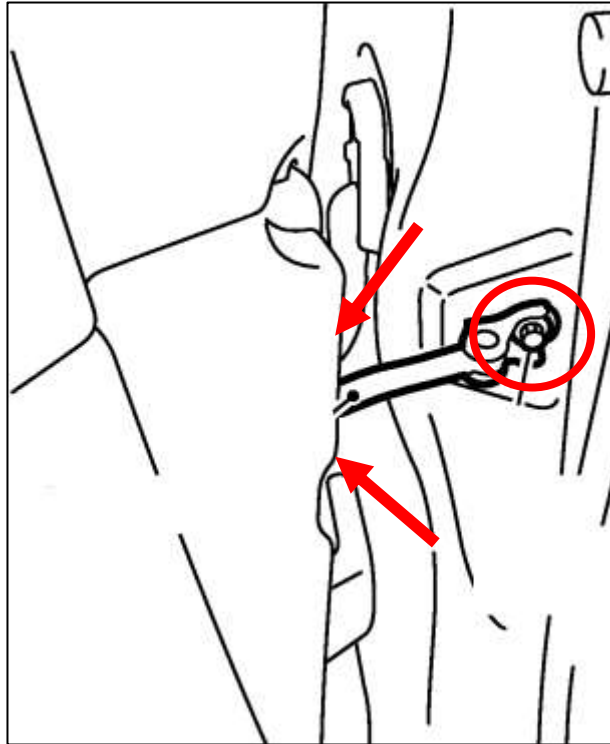

Figure 33

15. Pull the Check Link through the Speaker Hole to remove it.
16. Continue to the [TAB CHECK LINK](#) section for Check Link disassembly and Door Stopper Installation.
17. Follow *Steps 3-15* in reverse order to reinstall the Check Link and Door Panel.
18. Repeat *Steps 2-17* for the Passenger Side of the vehicle.

370Z

1. Place the transmission in Park position (or in Reverse gear if equipped with a manual transmission). Apply the parking brake.
2. Open the Driver Side Door.
3. Next to the Door Handle, remove the small trim piece using a Trim Removal Tool. *Figure 34.*



Figure 34

4. Remove the (1) one 10mm Bolt behind the Trim Piece that was just removed. *Figure 35.*



Figure 35

5. Under the Lower Door Handle/Arm Rest, remove the small Trim Piece with a Trim Removal Tool. *Figure 36.*



Figure 36

6. Remove the (2) two 10mm Bolts that are behind the Trim Piece. *Figure 37.*



Figure 37

- Using a Trim Removal Tool, pry the lower side of the Door Panel away from the door. Slowly go around the entire Door Panel to release it from the Door. Support the Door Panel from falling when it is released. *Figure 38.*



Figure 38

- Remove the Door Lock and Door Handle Cables from the Door Panel. They will easily pop out. *Figure 39.*

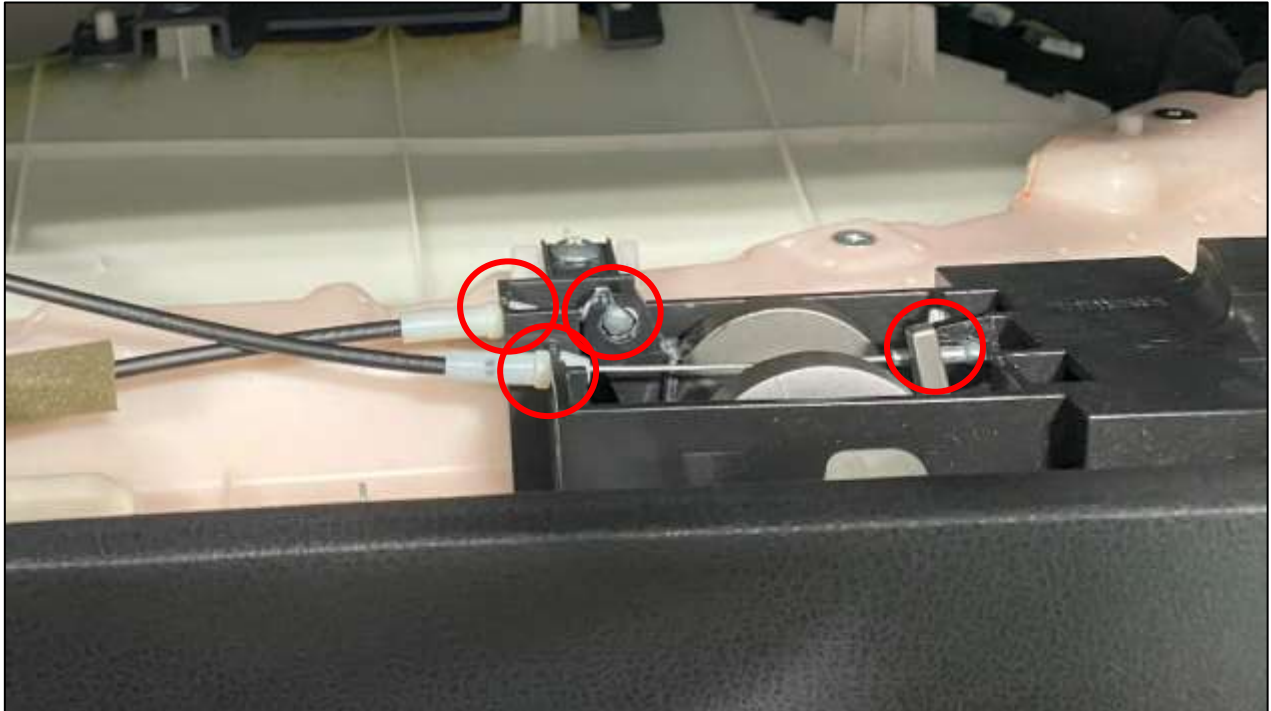

Figure 39

9. Disconnect the (2) two Door Panel Control connectors at the bottom of the Door Panel. *Figure 40.*

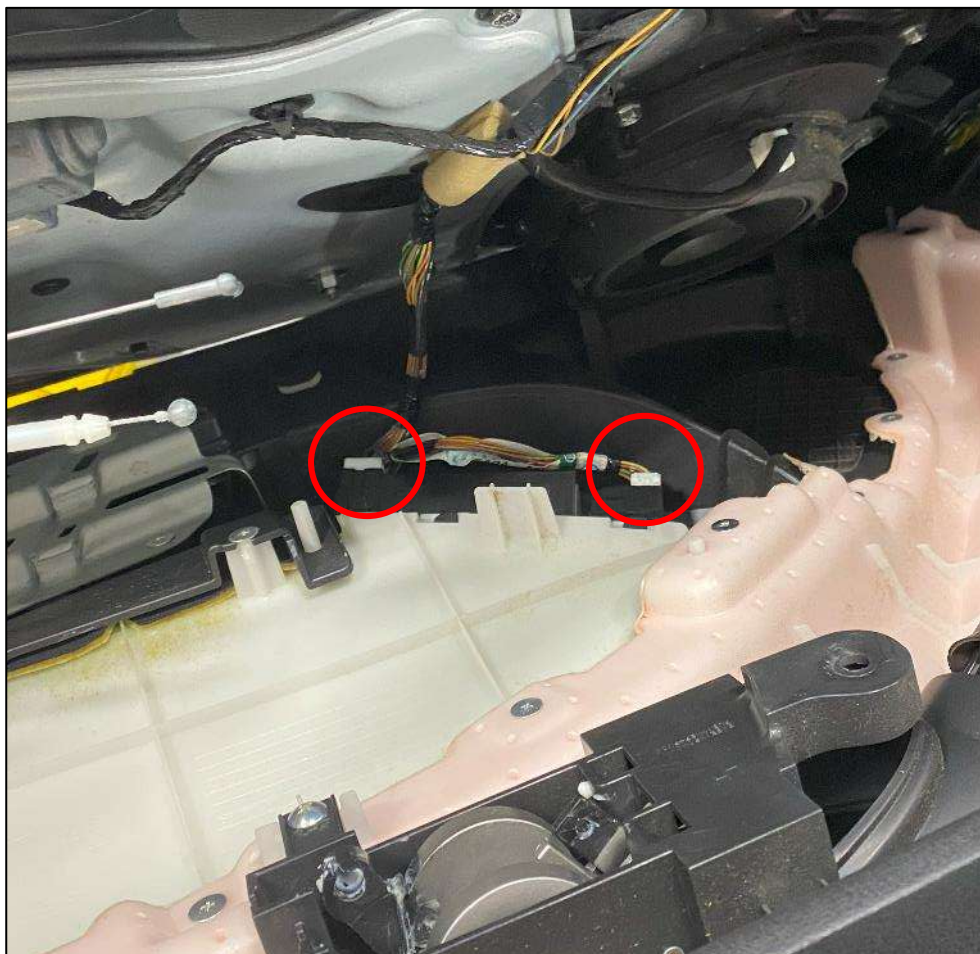

Figure 40

10. Remove and set aside the Door Panel. *Figure 41.*



Figure 41

11. Disconnect the (4) four 10mm Bolts securing the Speaker to the Door. *Figure 42.*

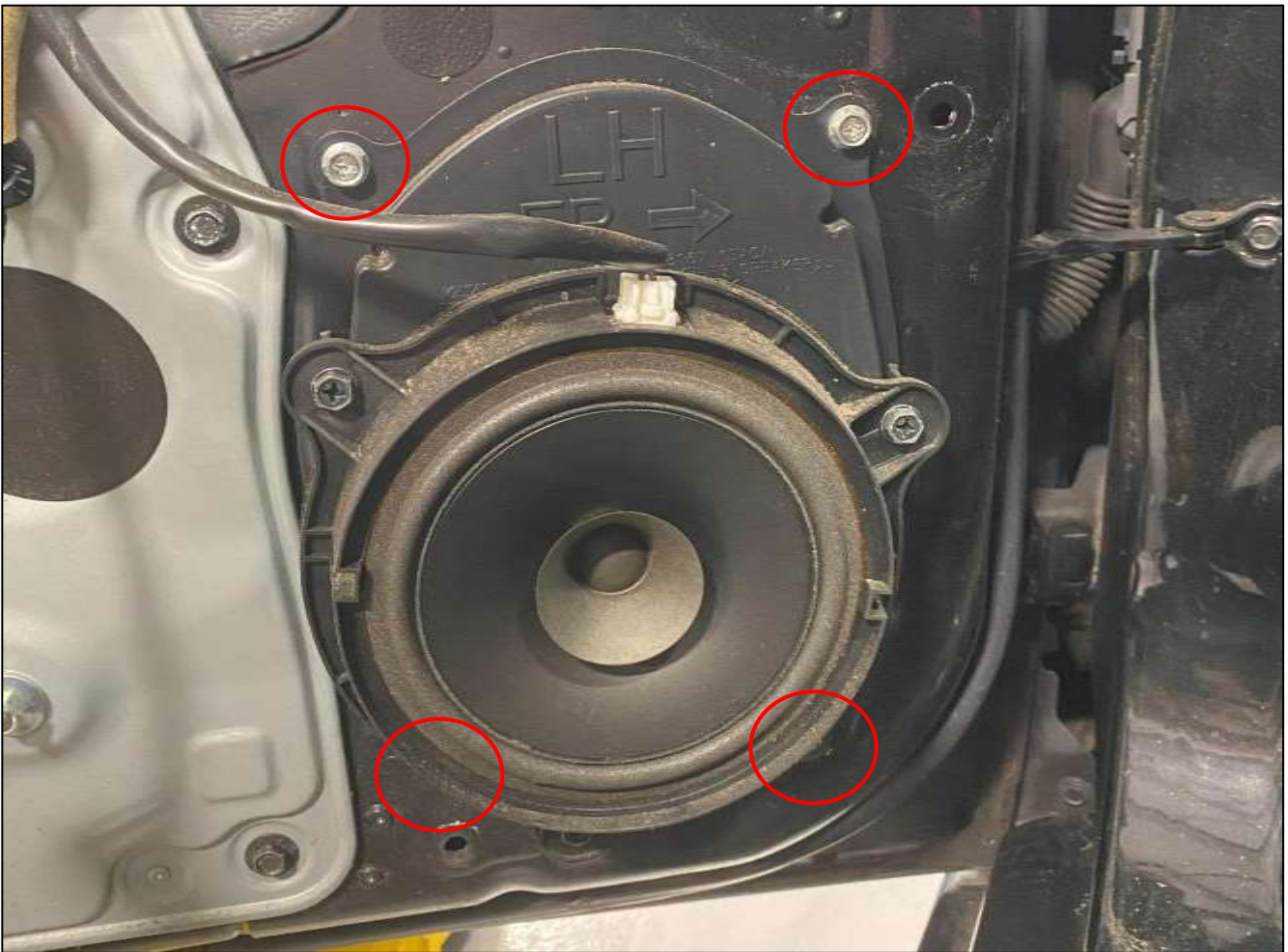

Figure 42

12. Remove the Speaker from the Door. You can optionally let the Speaker hang or disconnect the Electrical Connector and set the Speaker aside. *Figure 43.*



Figure 43

13. Open the Door as wide as you can. Disconnect the (3) three 10mm Bolts that secure the Check Link to the Door and the Body. *Figure 44.*



Figure 44

14. Once the Bolts are removed, pull the Check Link through the Speaker hole to remove it.
15. Continue to the [BOLTED CHECK LINK](#) section for Check Link disassembly and Door Stopper Installation.
16. Follow *Steps 3-14* in reverse order to reinstall the Check Link and Door Panel.
17. Repeat *Steps 2-16* for the Passenger Side of the vehicle.

G37 COUPE

1. Place the transmission in Park position (or in Reverse gear if equipped with a manual transmission). Apply the parking brake.
2. Open the Driver Side Door.
3. Behind the Door Handle, remove the small trim piece using a Trim Removal Tool. *Figure 45.*

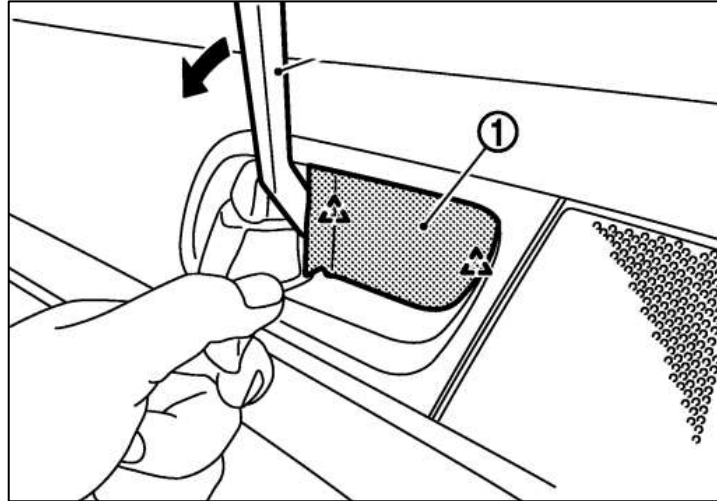

Figure 45

4. Remove the (1) one 10mm Bolt behind the Trim Piece that was just removed. *Figure 46.*

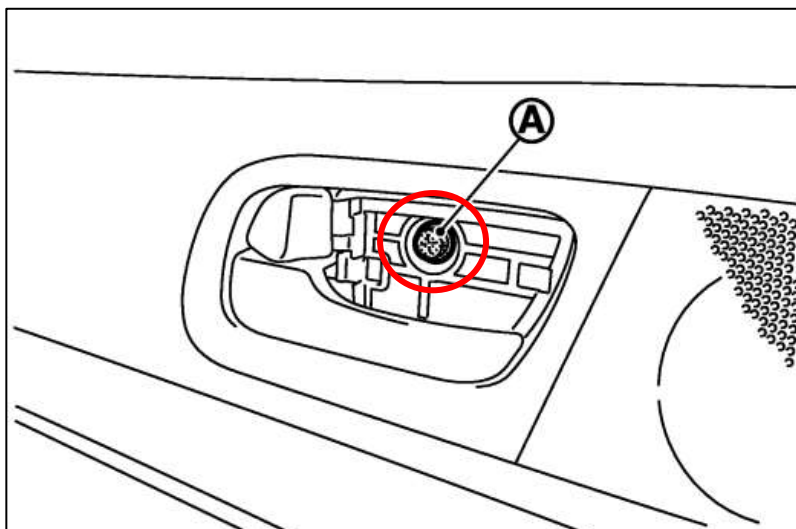

Figure 46

5. Remove the Trim Piece covering the Arm Rest. *Figure 47.*

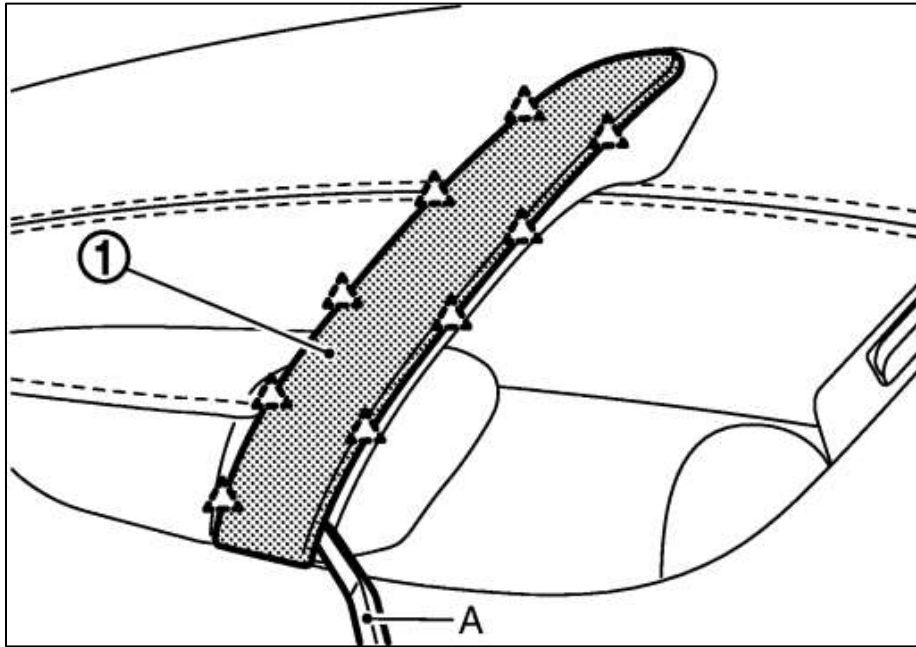

Figure 47

6. Remove the (2) two 10mm Bolts that are behind the Trim Piece. *Figure 48.*

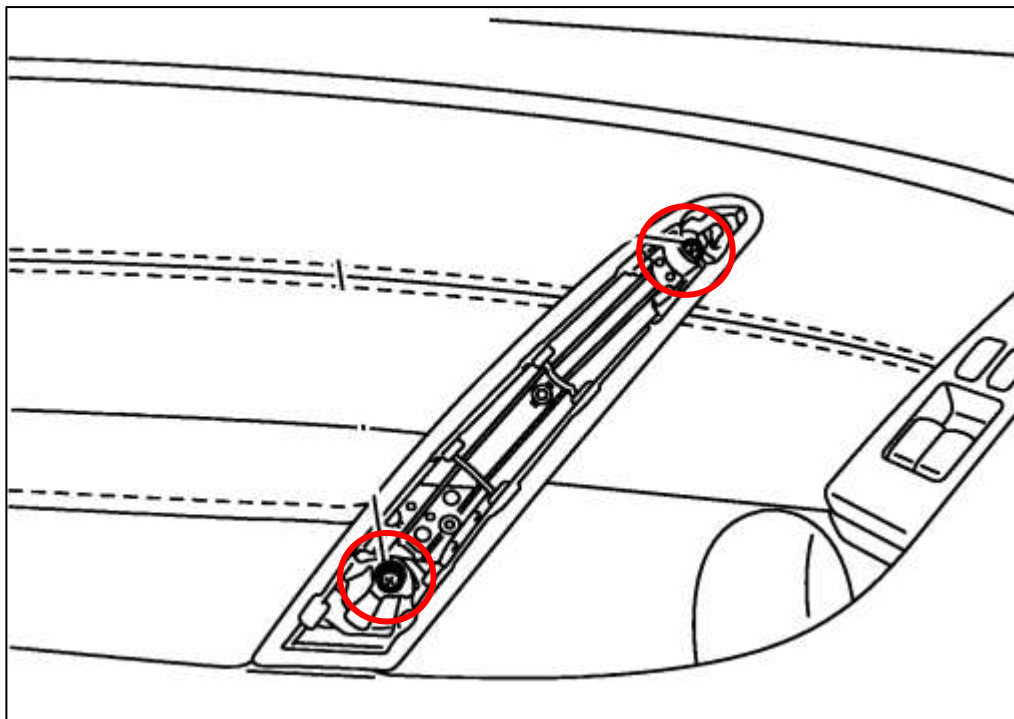

Figure 48

7. Remove the Step Lamp from the Door Panel. *Figure 49.*

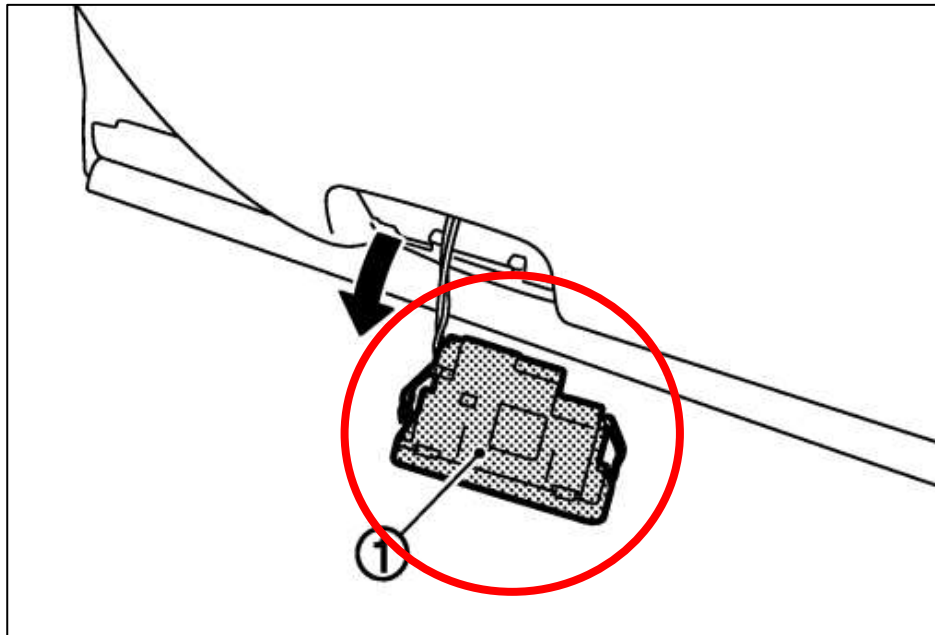

Figure 49

8. Using a Trim Removal Tool, pry the lower side of the Door Panel away from the door. Slowly go around the entire Door Panel to release it from the Door. Support the Door Panel from falling when it is released. *Figure 50.*

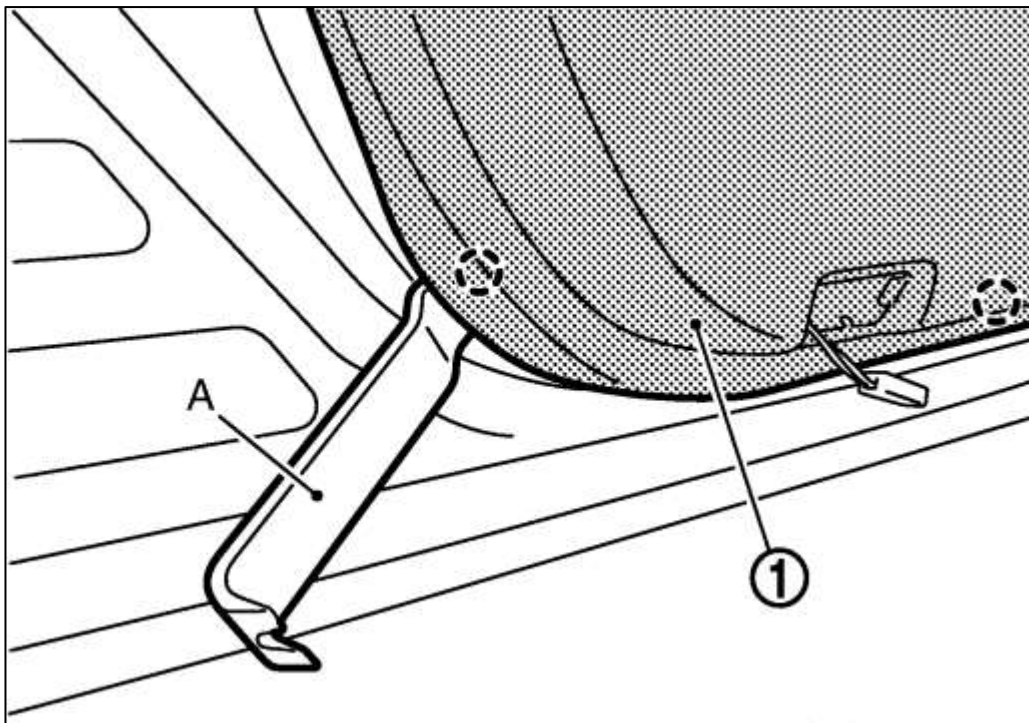

Figure 50

9. Remove the Door Lock and Door Handle Cables from the Door Panel.
10. Disconnect the (2) two Door Panel Control connectors at the bottom of the Door Panel. *Figure 51.*

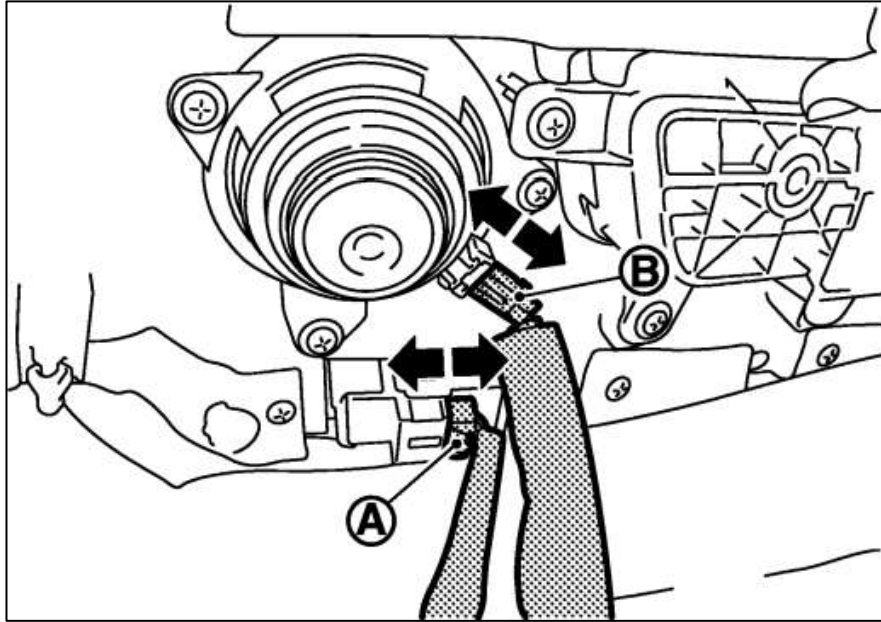

Figure 51

11. Remove and set aside the Door Panel.
12. Disconnect the (5) five 10mm Bolts securing the Speaker to the Door. *Figure 52.*

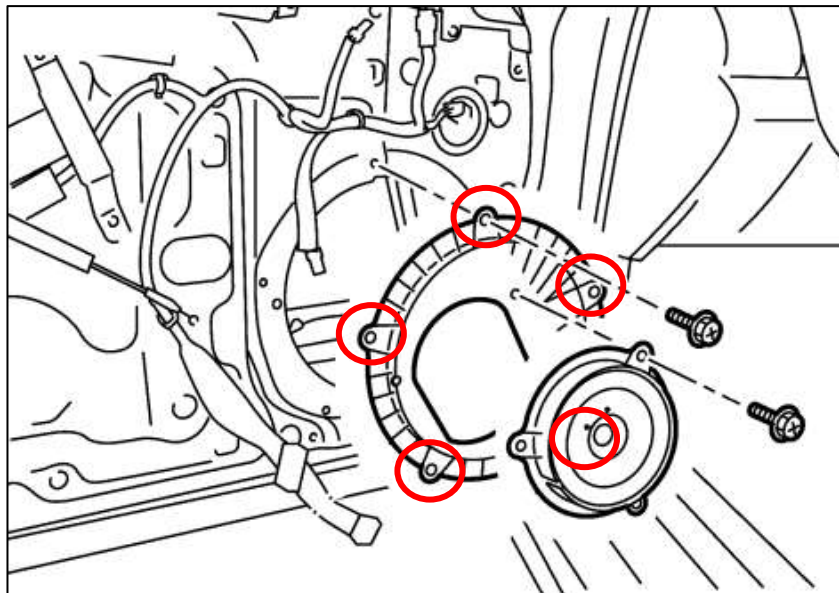

Figure 52

13. Remove the Speaker from the Door. You can optionally let the Speaker hang or disconnect the Electrical Connector and set the Speaker aside.
14. Open the Door as wide as you can. Disconnect the (3) three 10mm Bolts that secure the Check Link to the Door and the Body. *Figure 53.*

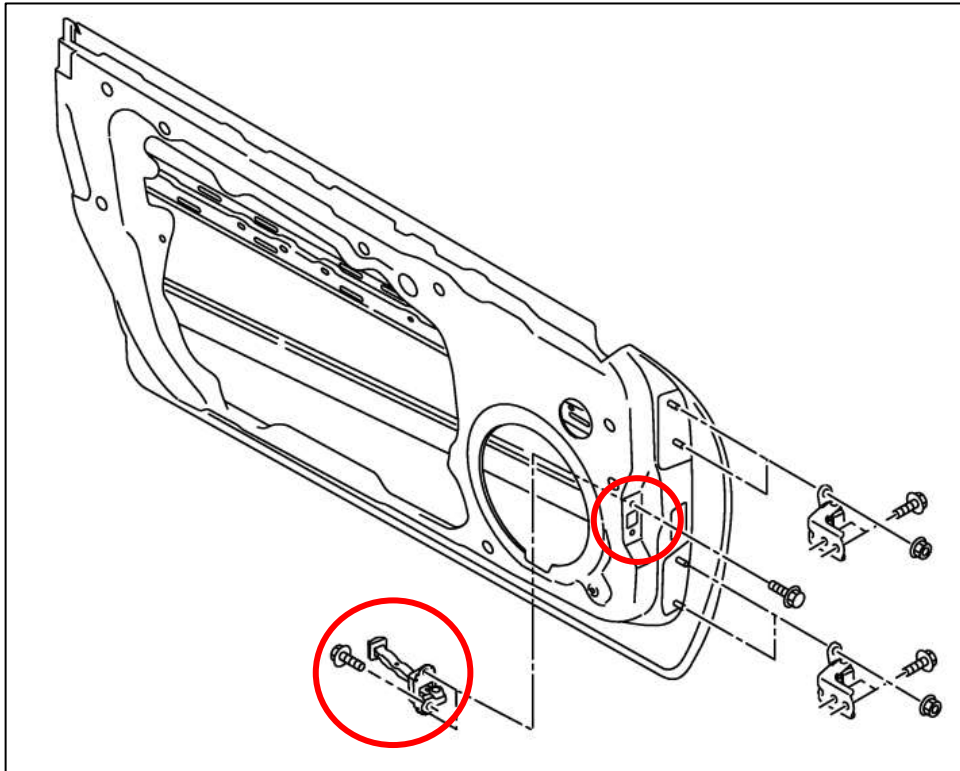

Figure 53

15. Once the Bolts are removed, pull the Check Link through the Speaker hole to remove it.
16. Continue to the [BOLTED CHECK LINK](#) section for Check Link disassembly and Door Stopper Installation.
17. Repeat *Steps 2-15* in reverse order to reinstall the Door Check Link and Door Panel.
18. Repeat *Steps 2-17* for the other side of the vehicle.

G37 SEDAN

FRONT DOOR

1. Open the Driver Side Door.
2. Behind the Door Handle, remove the small Trim Piece using a Trim Removal Tool. *Figure 54.*

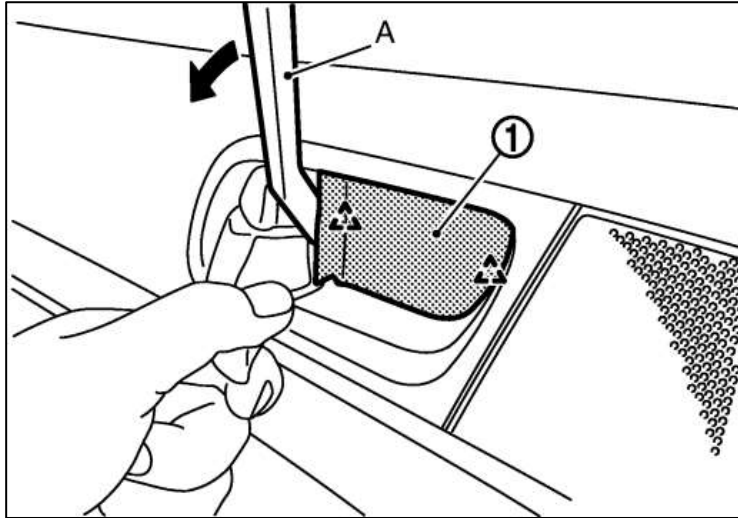

Figure 54

3. Remove the (1) one 10mm Bolt behind the Trim Piece that was just removed. *Figure 55.*

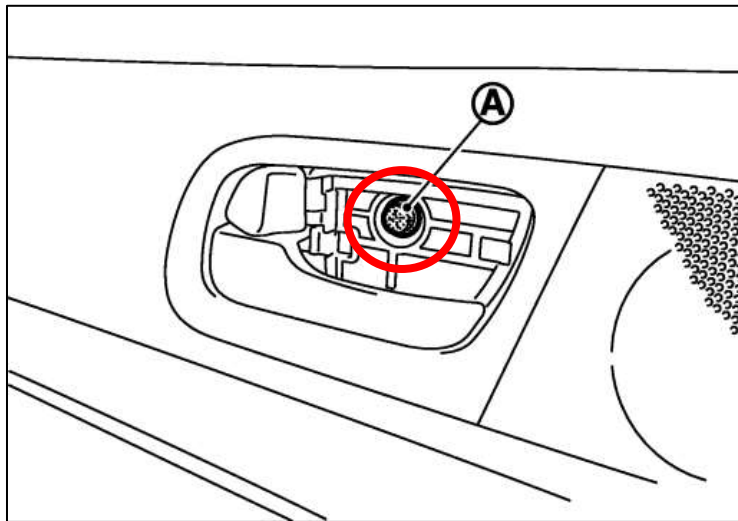

Figure 55

4. Remove the Door Control Panel with a Trim Removal Tool. *Figure 56.*

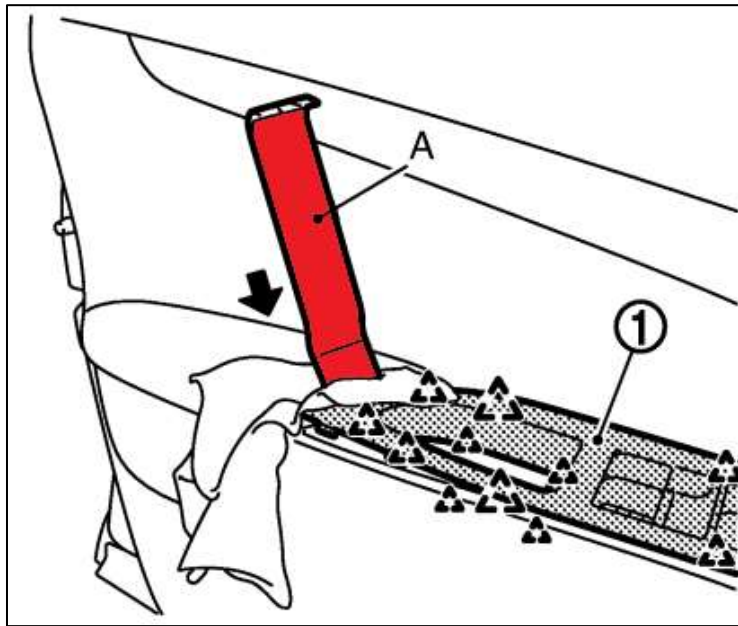

Figure 56

5. Remove the (2) two Bolts under the Door Control Panel. *Figure 57.*

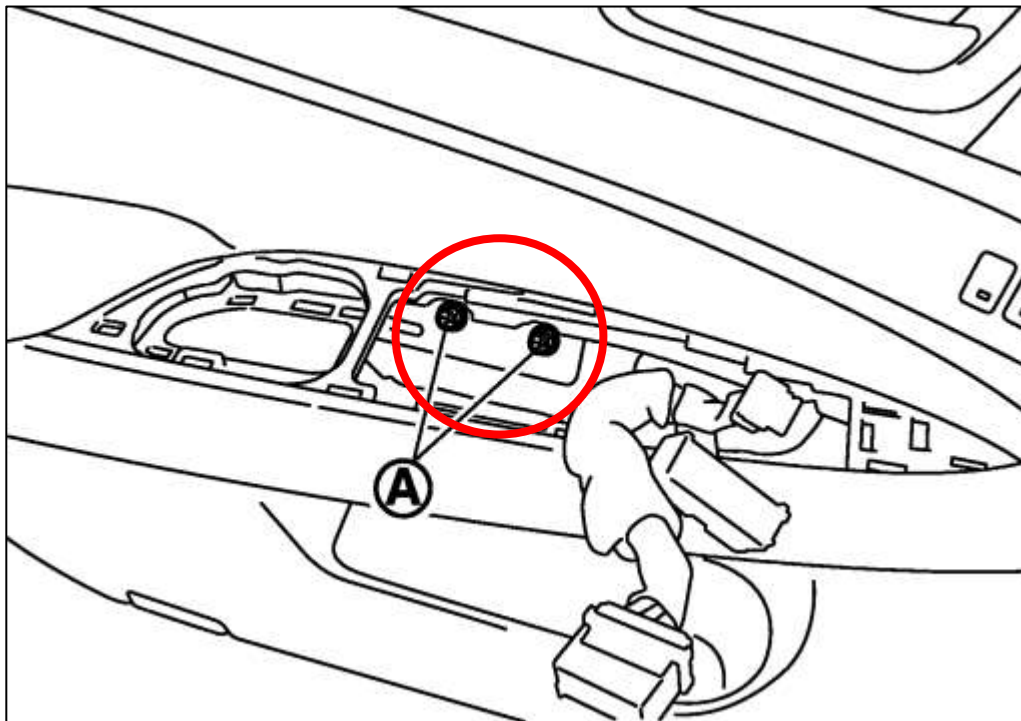

Figure 57

6. Disconnect the Step Lamp on the bottom of the Door Panel. *Figure 58.*

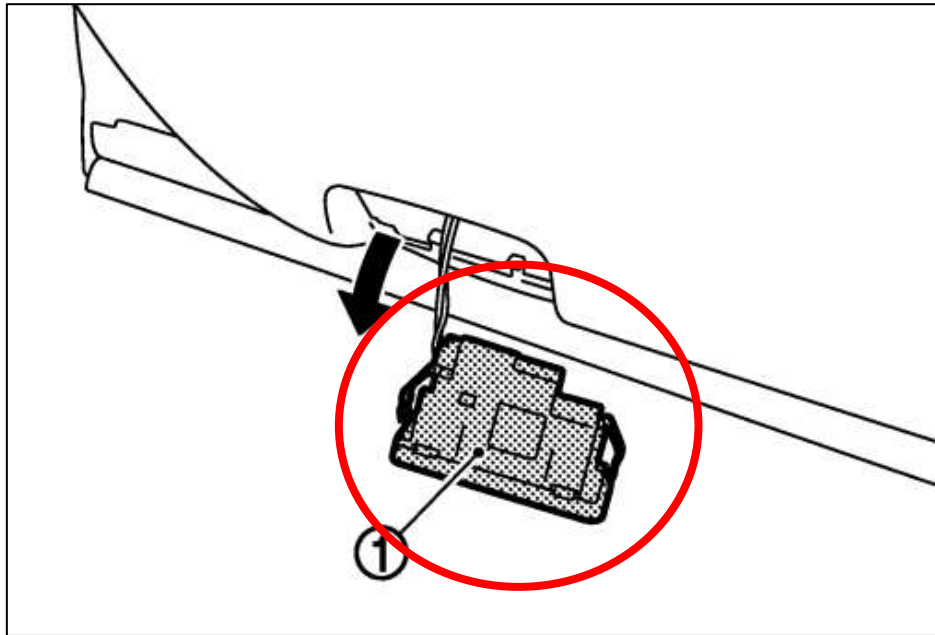

Figure 58

7. Starting at the bottom of the Door, use a Trim Removal tool to pry the Door Panel away from the Door. Once all clips are disconnected, pull up and away to remove the Door Panel. *Figure 59.*

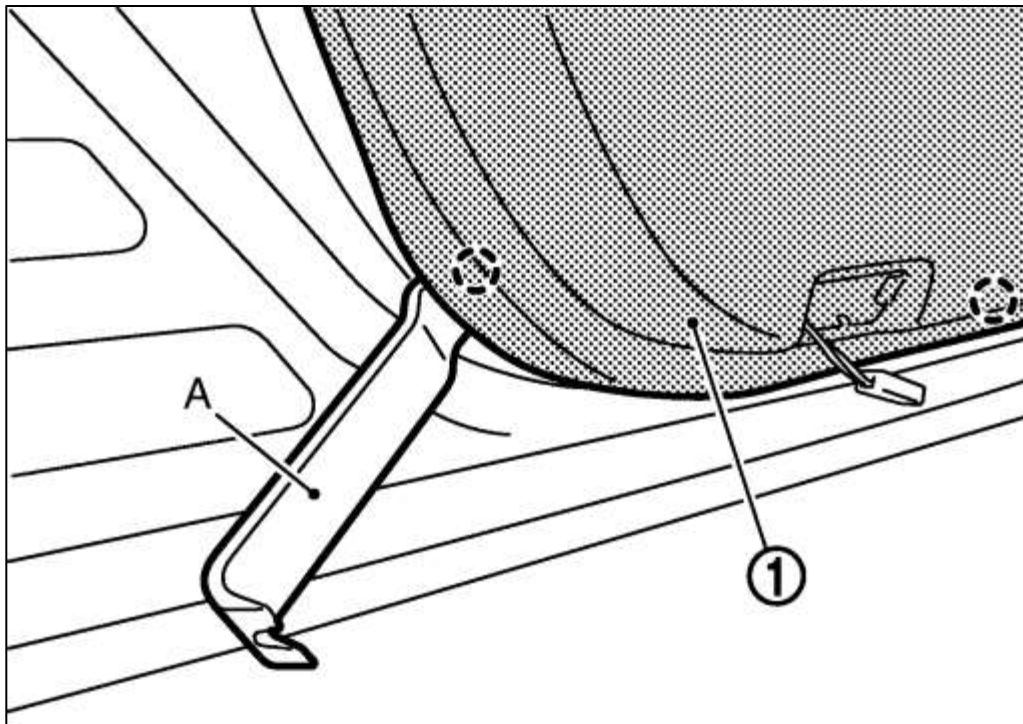

Figure 59

8. With the Door Panel disconnected, disconnect the electrical connectors as shown below. *Figure 60.*

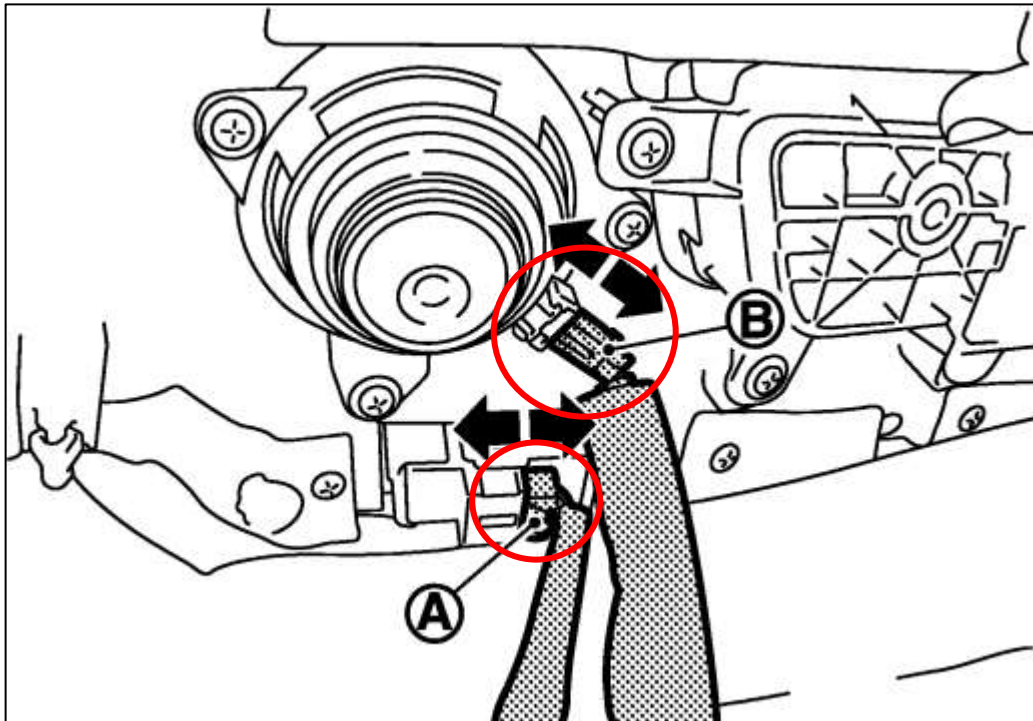

Figure 60

9. Disconnect the Door Lock and Door Handle Cables, they will easily pop out.

10. Remove the bolts securing the Door Speaker to the Door and remove the Speaker from the Door. *Figure 61.*

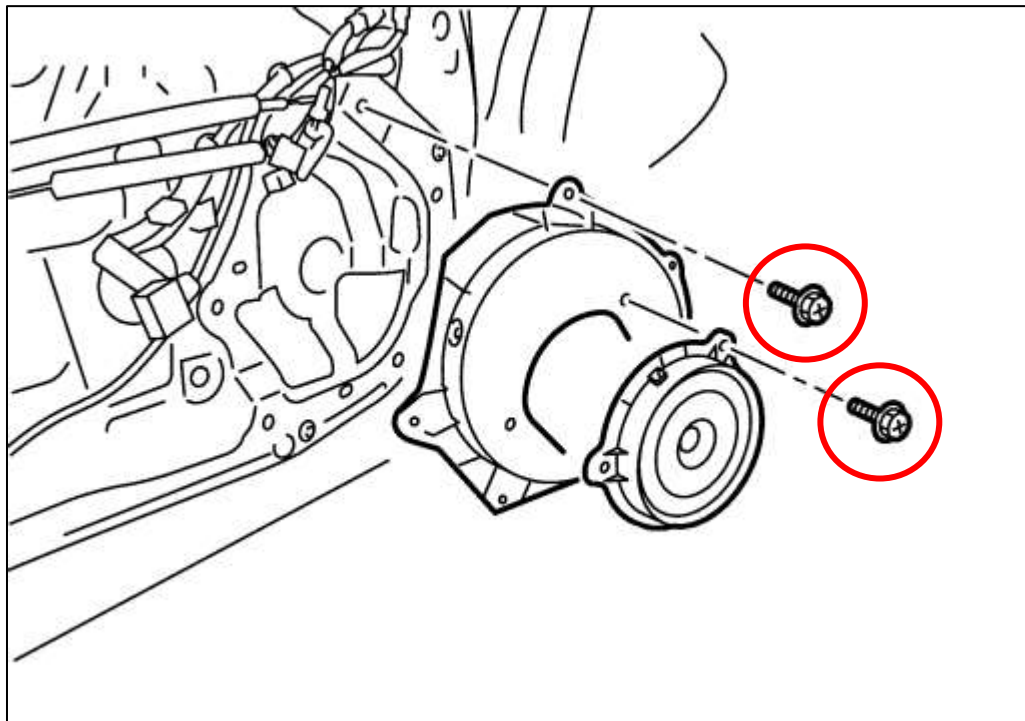

Figure 61

11. Open the door as wide as you can. Disconnect the (3) three 10mm Bolts that secure the Check Link to the vehicle. *Figure 62.*

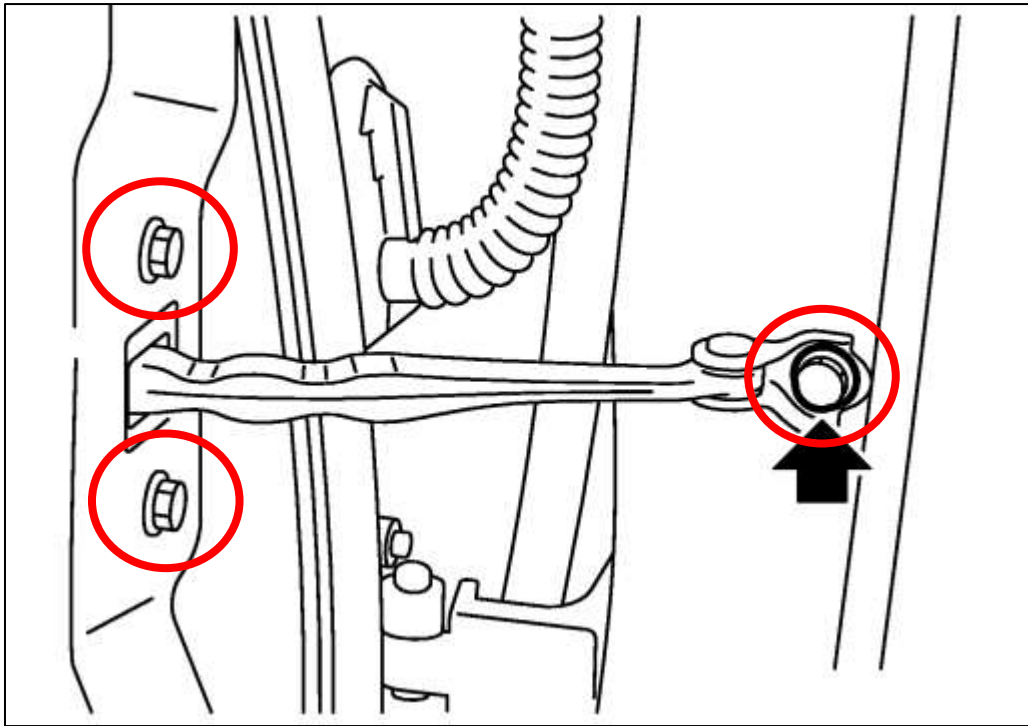

Figure 62

12. Once the bolts are removed, pull the Check Link through the Speaker hole in the door. *Figure 63.*

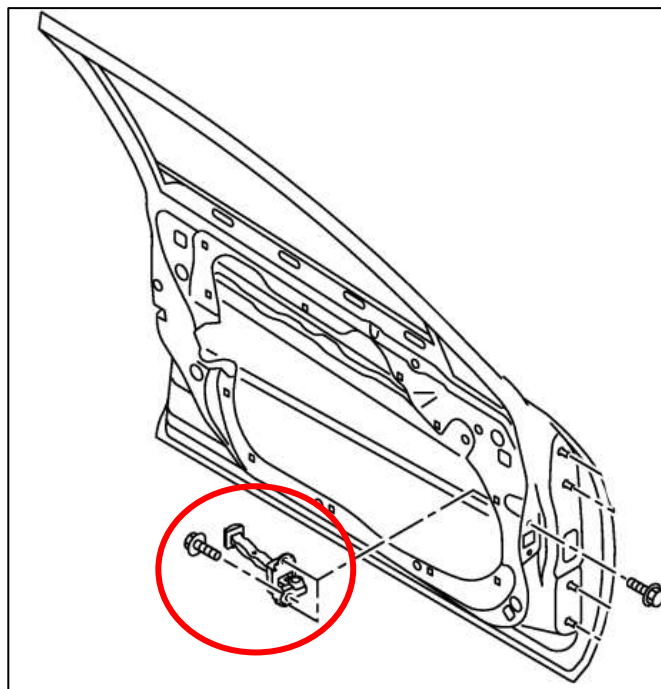

Figure 63

13. Continue to the [BOLTED CHECK LINK](#) section for Check Link disassembly and Door Stopper Installation.
14. Repeat Steps 2-12 in reverse order to reinstall the Door Check Link and Door Panel.
15. Repeat Steps 2-14 for the other side of the vehicle.

REAR DOOR

1. Open the Driver Side Door.
2. Behind the Door Handle, remove the small Trim Piece using a Trim Removal Tool. *Figure 64.*

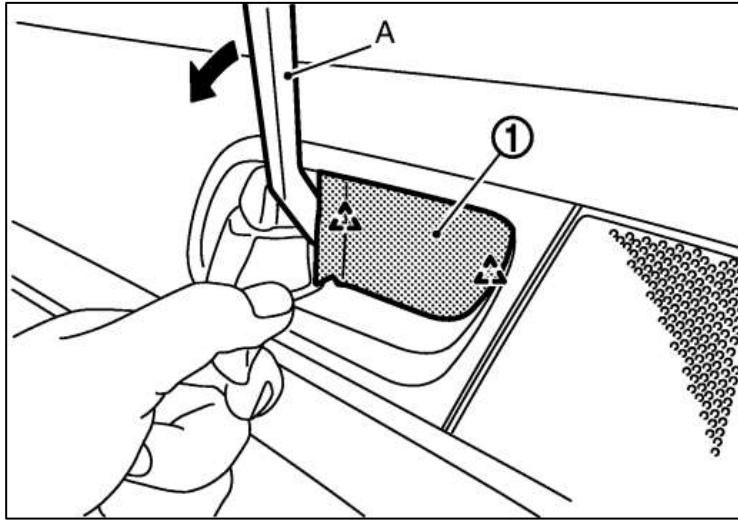

Figure 64

3. Remove the (1) one 10mm Bolt behind the Trim Piece that was just removed. *Figure 65.*

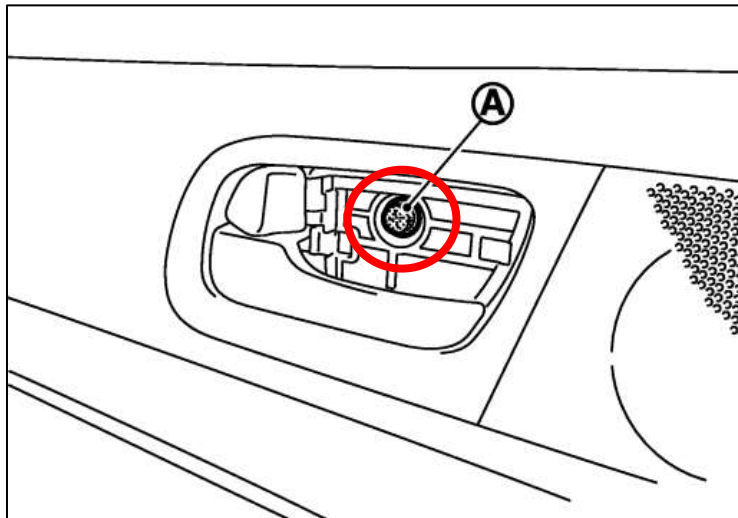

Figure 65

4. Remove the Door Control Panel with a Trim Removal Tool. *Figure 66.*

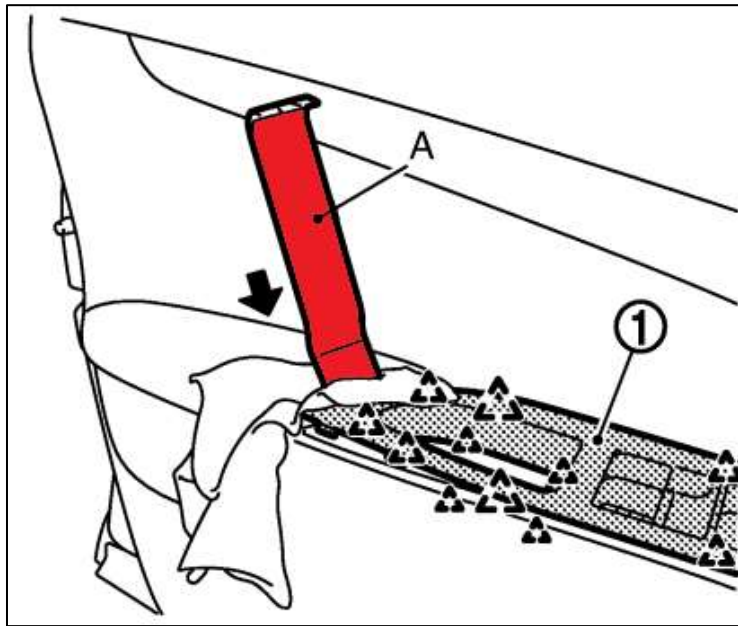

Figure 66

5. Remove the (2) two Bolts under the Door Control Panel. *Figure 67.*

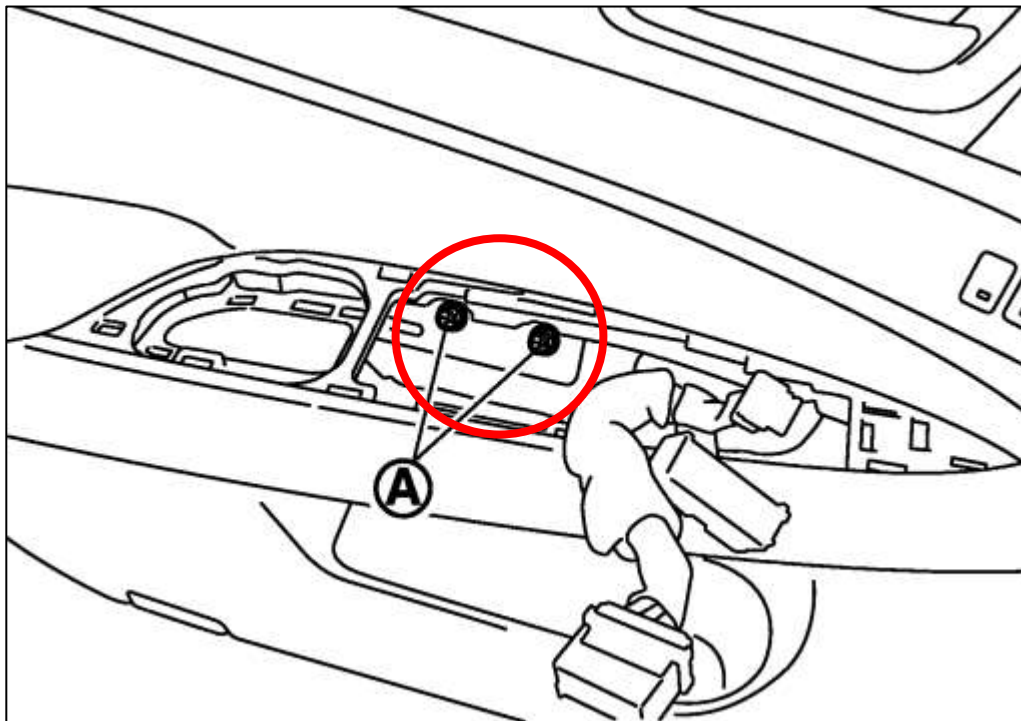

Figure 67

6. Disconnect the Step Lamp on the bottom of the Door Panel. *Figure 68.*

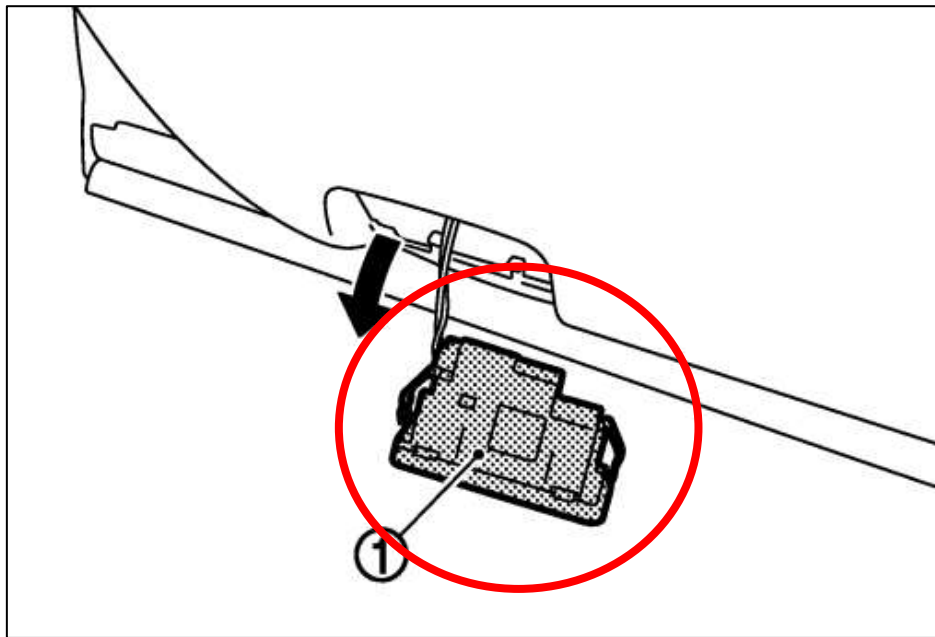

Figure 68

7. Starting at the bottom of the Door, use a Trim Removal tool to pry the Door Panel away from the Door. Once all clips are disconnected, pull up and away to remove the Door Panel. *Figure 69.*

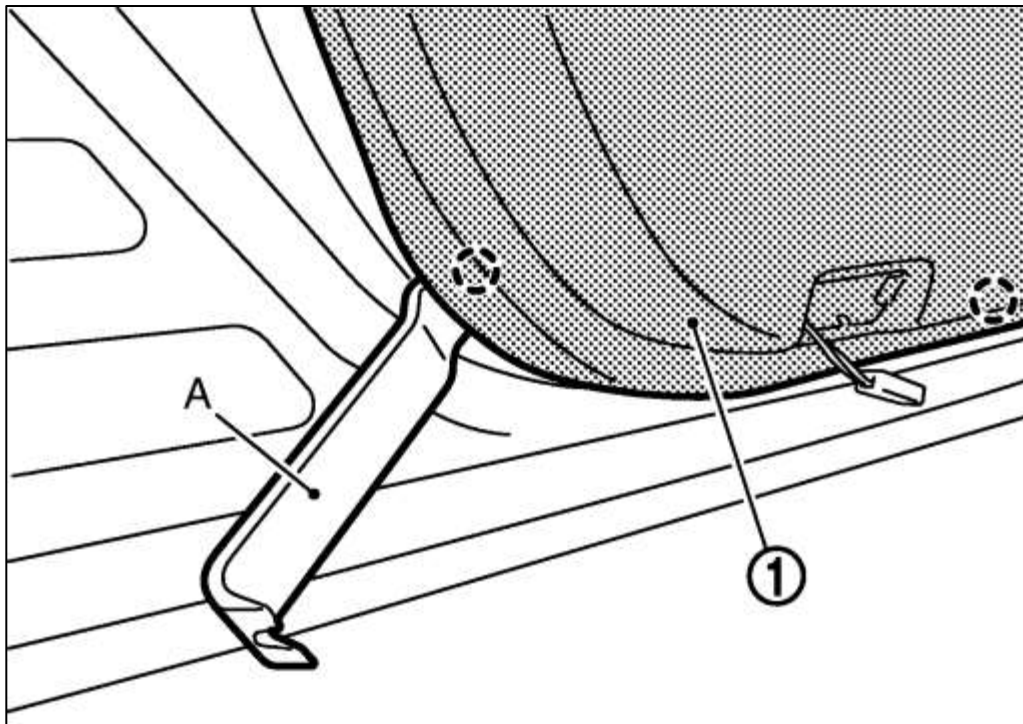

Figure 69

8. With the Door Panel disconnected, disconnect the electrical connectors as shown below. *Figure 70*

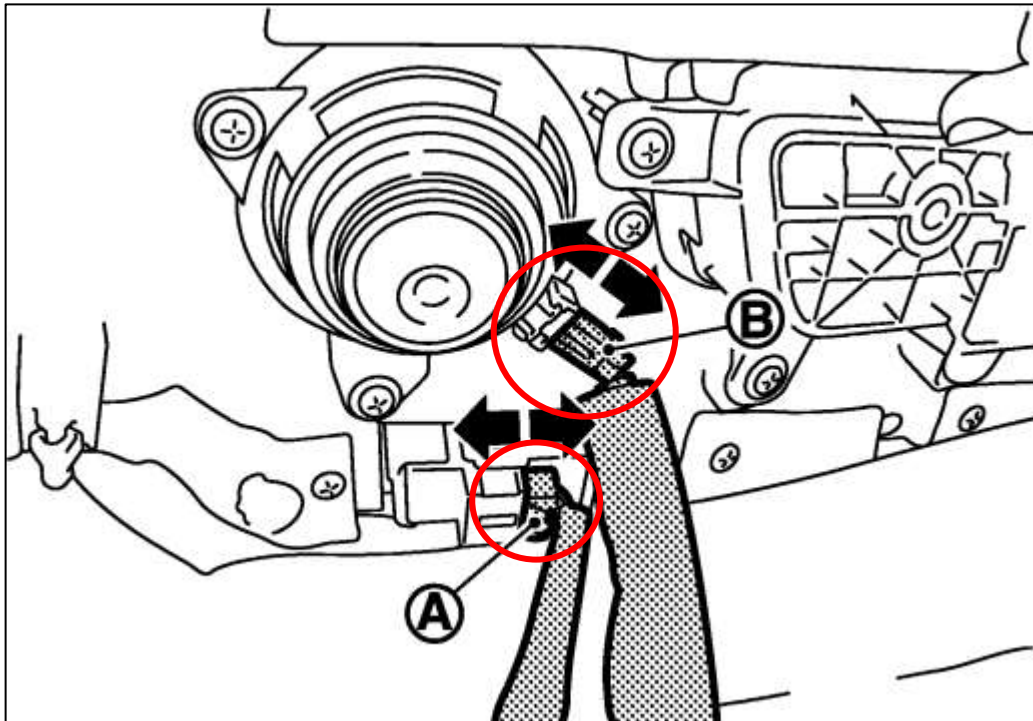

Figure 70

9. Disconnect the Door Lock and Door Handle Cables, they will easily pop out.

10. Remove the bolts securing the Door Speaker to the Door and remove the Speaker from the Door. *Figure 71.*

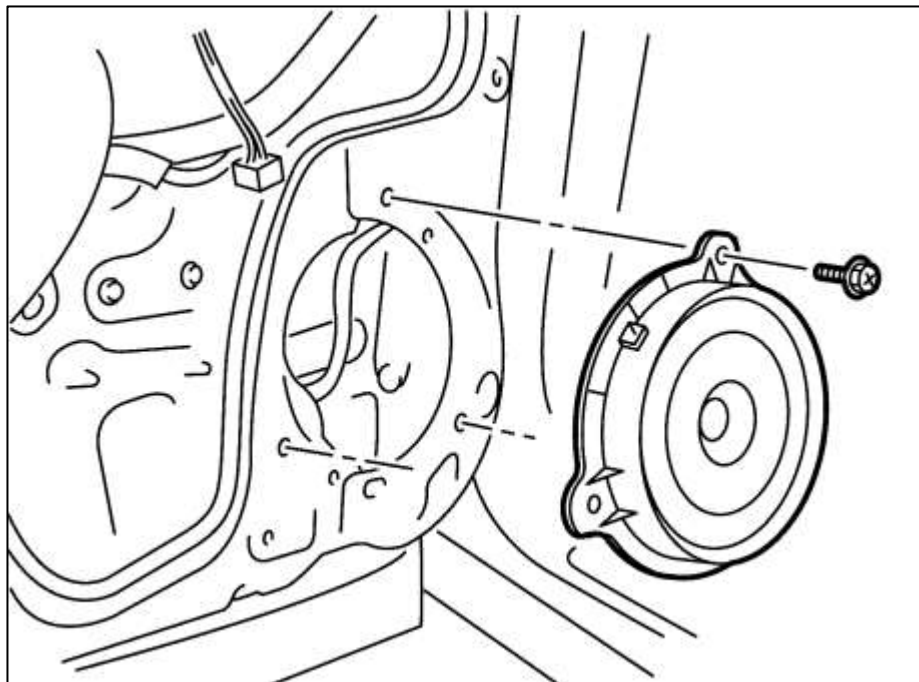

Figure 71

11. Open the door as wide as you can. Disconnect the (3) three 10mm Bolts that secure the Check Link to the vehicle. *Figure 72.*

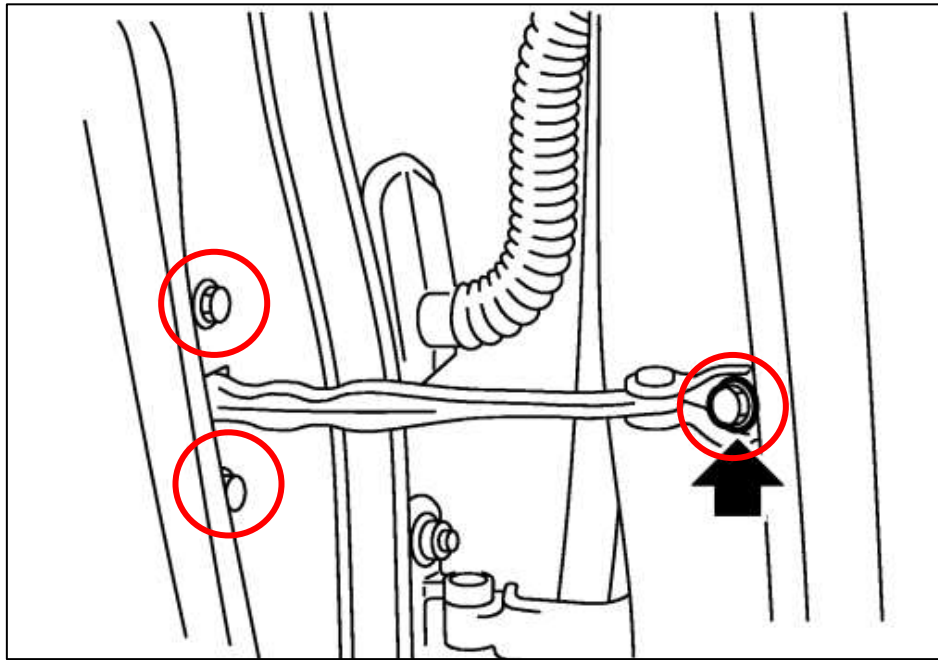

Figure 72

12. Once the bolts are removed, pull the Check Link through the Speaker hole in the door. *Figure 73.*

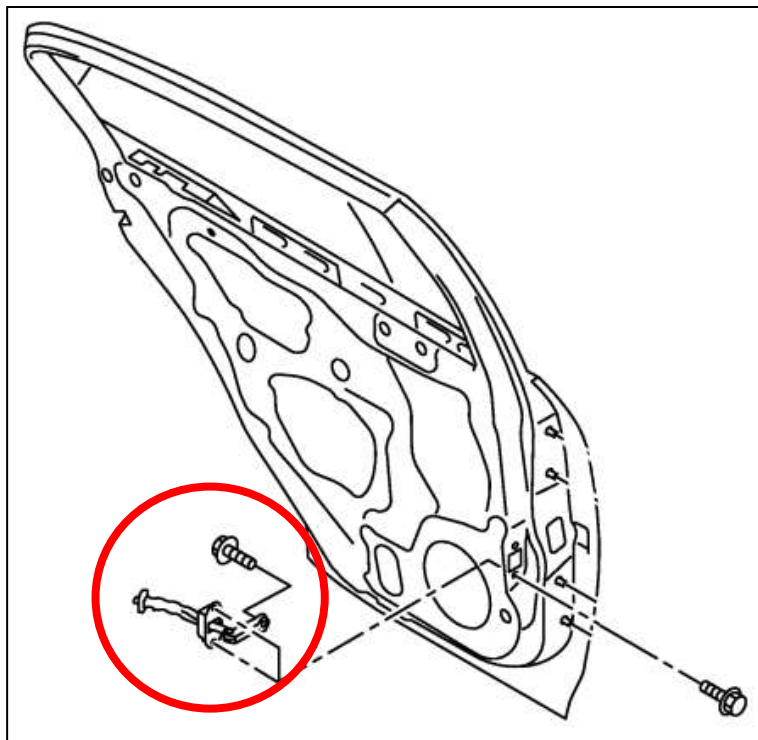

Figure 73

13. Continue to the [BOLTED CHECK LINK](#) section for Check Link disassembly and Door Stopper Installation.

14. Repeat Steps 2-12 in reverse order to reinstall the Door Check Link and Door Panel.

15. Repeat Steps 2-14 for the other side of the vehicle.

D40 FRONTIER

FRONT DOOR

1. Open the Driver Side Door.
2. Remove the Trim Piece behind the Door Handle with a Trim Removal Tool. *Figure 74.*

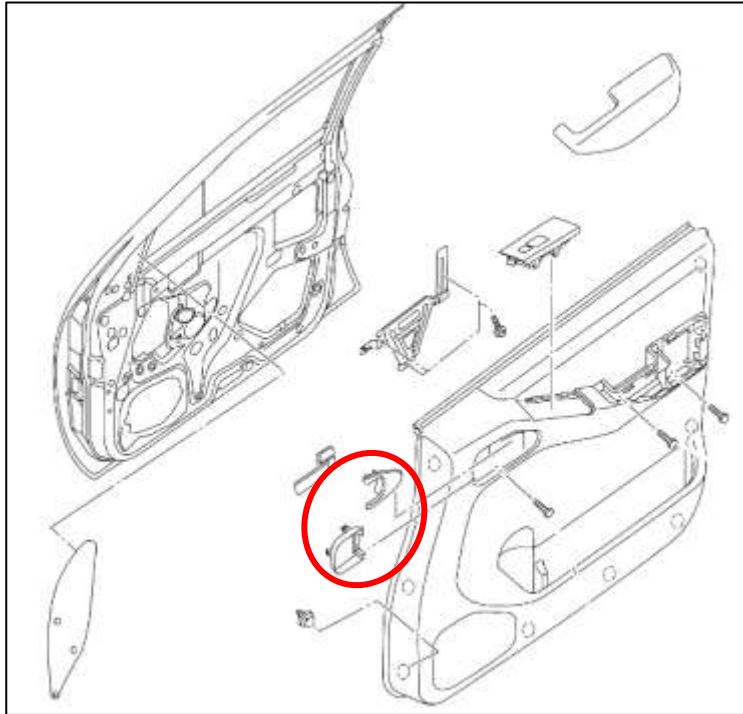

Figure 74

3. Remove the Trim Piece on the Arm Rest with a Trim Removal Tool. *Figure 75.*

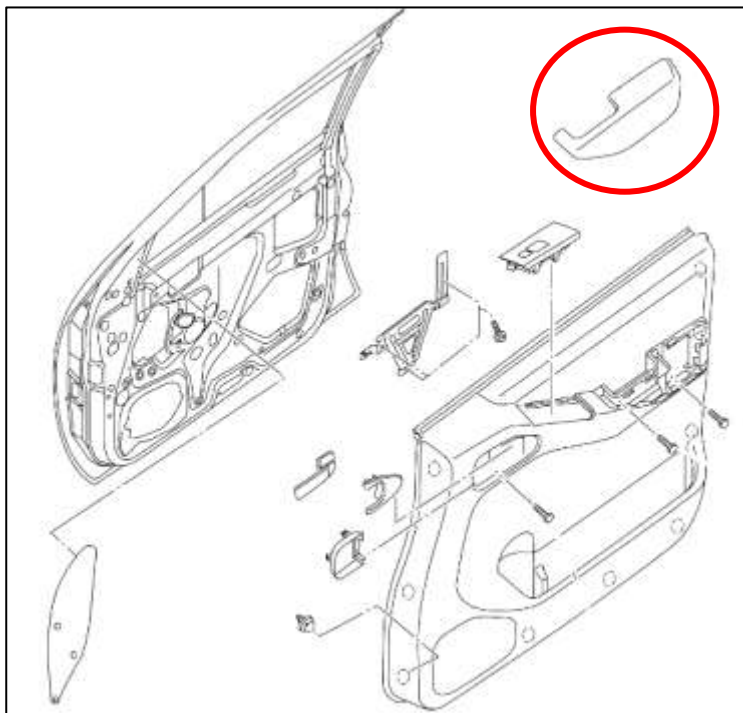

Figure 75

4. Pry up the Door Control Panel with a Trim Removal Tool. *Figure 76.*

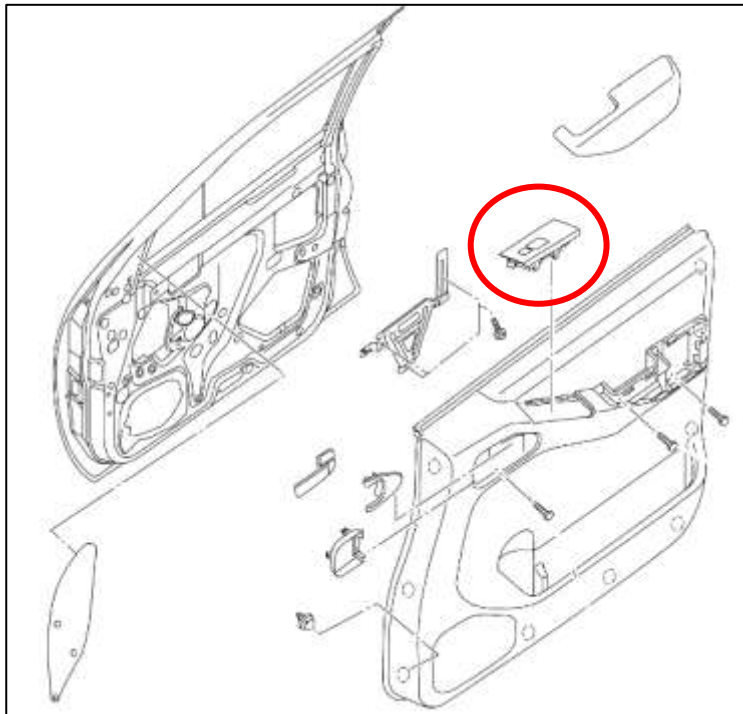

Figure 76

5. Disconnect the Door Control Panel electrical connector and set the Control Panel aside.
6. Remove the (3) three bolts securing the Door Panel to the Door. *Figure 77.*

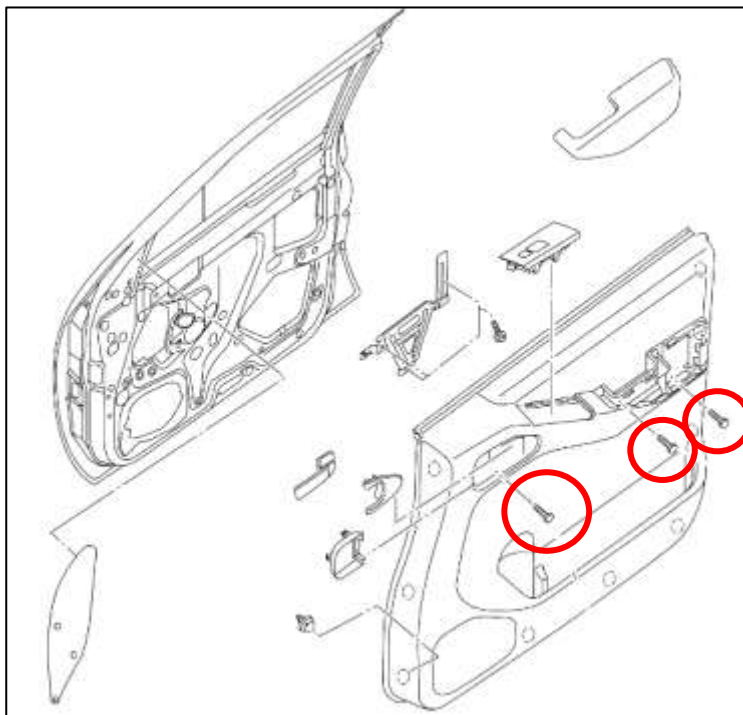

Figure 77

7. Pull on the lower half of the Door Panel to disengage it from the Door and slowly work your way around the rest of the panel until it is fully removed.
8. Remove the Trim Piece in the corner of the Door with a Trim Removal Tool. *Figure 78.*

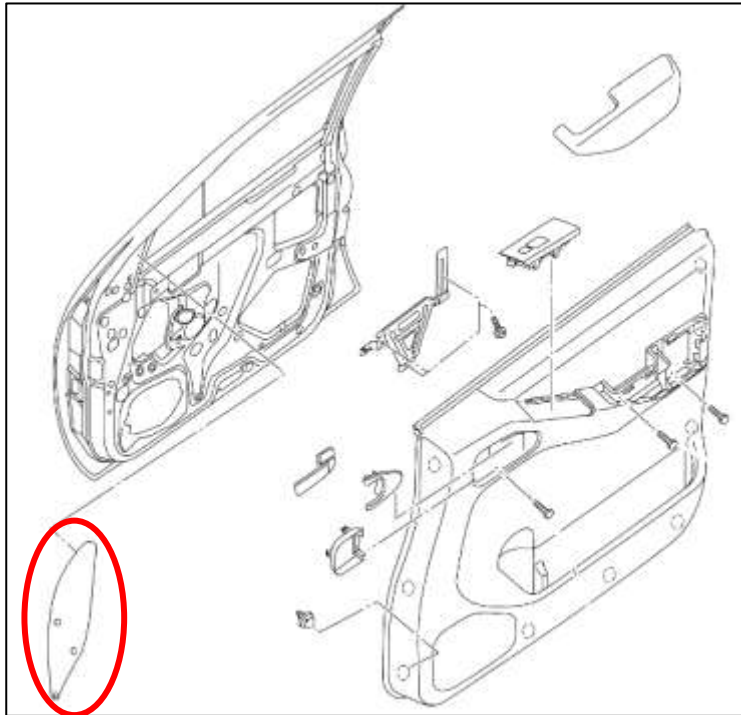

Figure 78

9. Peel up the Sound Deadening/Vapor Seal on the side of the Door to provide access to remove the Door Stopper/Hinge Assembly. *Figure 79.*



Figure 79

10. Remove the (3) three 10mm bolts securing the Check link to the vehicle. *Figure 80.*



Figure 80

11. Remove the Check Link from the inside of the Door behind the Sound Deadening.

12. Continue to the [TAB CHECK LINK](#) section for Check Link disassembly and Door Stopper Installation.

13. Follow *Steps 2-11* in reverse order to reinstall the Door Stopper and Door Panel.

14. Repeat *Steps 2-13* for the other side of the vehicle.

REAR DOOR

1. Open the Driver Side Rear Door.
2. Remove the Trim Piece behind the Door Handle with a Trim Removal tool. *Figure 81.*

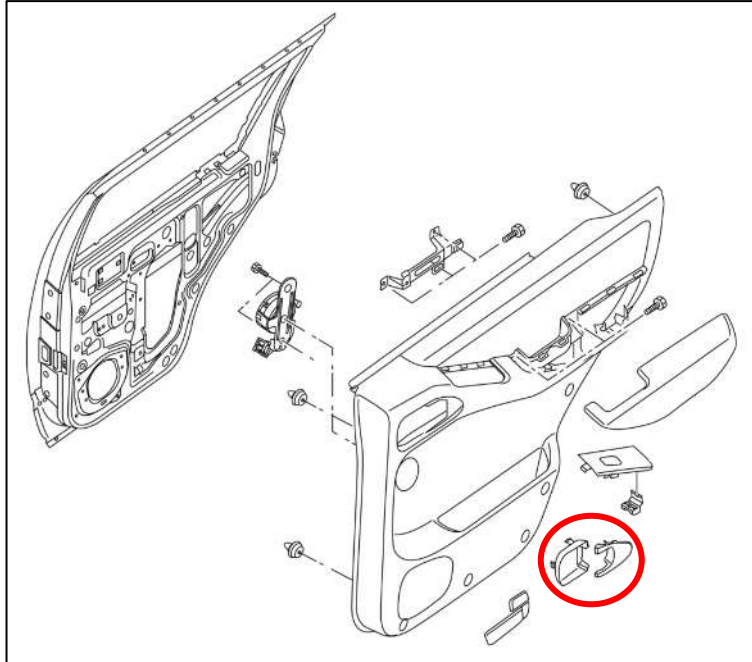

Figure 81

3. Remove the Trim Piece on the Arm Rest with a Trim Removal tool. *Figure 82.*

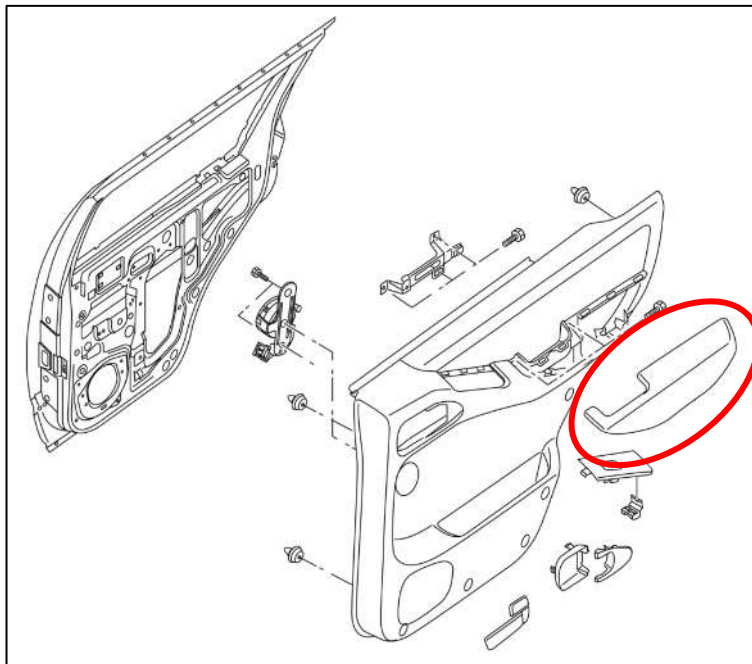

Figure 82

4. Pry up the Door Control Panel with a Trim Removal tool. *Figure 83.*

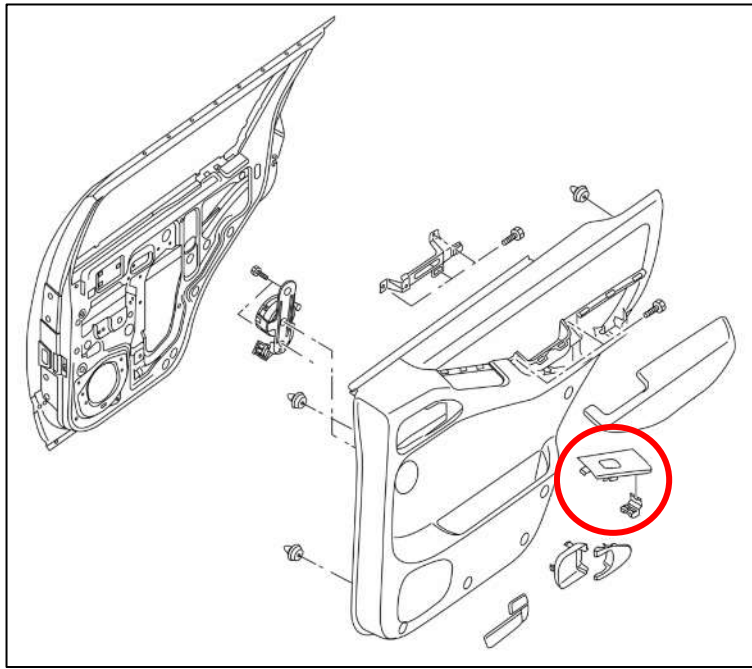

Figure 83

5. Disconnect the Door Control Panel electrical connector and set the Control Panel aside.
6. Remove the (2) two bolts securing the Door Panel to the Door. *Figure 84.*

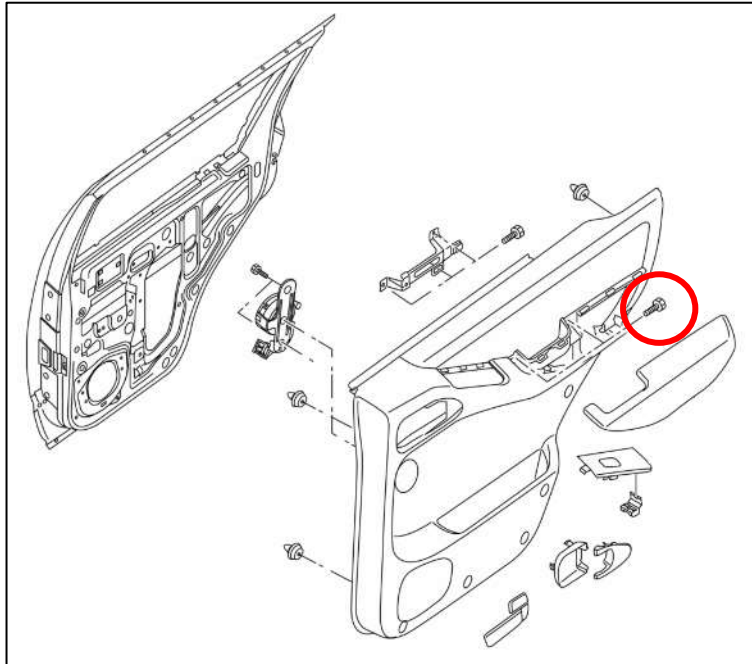

Figure 84

7. Pull on the lower half of the Door Panel to disengage it from the Door and slowly work your way around the rest of the Panel until it is fully removed.

8. Peel up the Sound Deadening/Vapor Seal on the side of the Door to provide access to remove the Check Link. *Figure 85.*



Figure 85

9. Remove the (3) three 10mm bolts securing the Check Link to the vehicle. *Figure 86.*



Figure 86

10. Remove the Check Link from the inside of the door behind the Sound Deadening/Vapor Barrier.
11. Continue to the [TAB CHECK LINK](#) section for Check Link disassembly and Door Stopper Installation.
12. Follow *Steps 2-10* in reverse order to reinstall the Door Stopper and Door Panel.
13. Repeat *Steps 2-12* for the Passenger Side Rear Door.

N50 XTERRA

FRONT DOOR

1. Open the Driver Side Door.
2. Remove the Trim Piece on the Arm Rest using a Trim Removal tool. *Figure 87.*



Figure 87

3. Remove the Trim Piece around the Door Handle using a Trim Removal tool. *Figure 88.*



Figure 88

4. Pry up the Door Control Panel using a Trim Removal tool.
5. Disconnect the electrical connector from the Door Control Panel and set the Panel aside. *Figure 89.*



Figure 89

6. Remove the (3) three 10mm bolts securing the Door Panel to the Door. *Figure 90.*

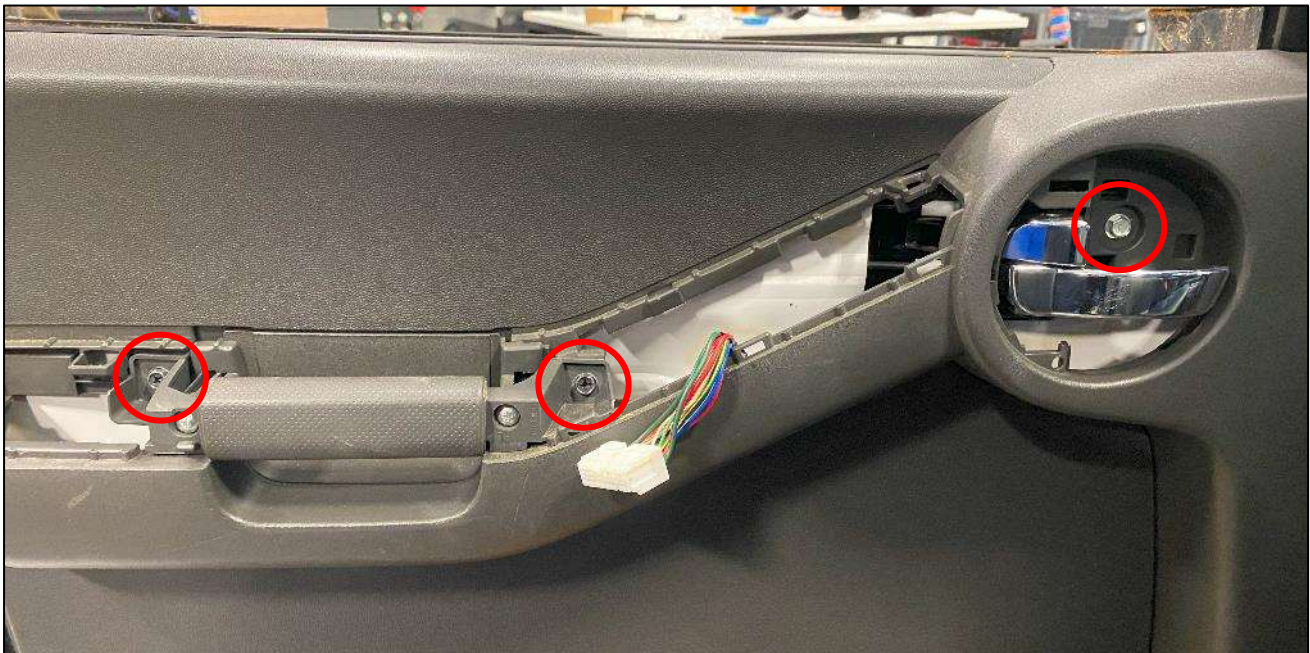

Figure 90

7. Grab the bottom part of the Door Panel and pull it to release it from the Door. Slowly pull the entire Door Panel away until it is released.
8. Peel up the Sound Deadening/Vapor Seal on the side of the Door to provide access to remove the Check Link. *Figure 91.*



Figure 91

9. Remove the Trim Piece in the corner of the Door with a Trim Removal Tool. *Figure 92.*



Figure 92

10. Remove the (3) three 10mm bolts securing the Check Link to the vehicle. *Figure 93.*



Figure 93

11. Remove the Check Link from the inside of the door behind the Sound Deadening/Vapor Barrier.
12. Continue to the [TAB CHECK LINK](#) section for Check Link disassembly and Door Stopper Installation.
13. Follow *Steps 2-11* in reverse order to reinstall the Check Link and Door Panel.
14. Repeat *Steps 2-13* for the other side of the vehicle.

REAR DOOR

1. Open the Driver Side Rear Door.
2. Remove the Trim Piece on the Arm Rest using a Trim Removal tool. *Figure 94.*



Figure 94

3. Remove the Trim Piece around the Door Handle using a Trim Removal tool. *Figure 95.*



Figure 95

4. Pry up the Door Control Panel using a Trim Removal tool. *Figure 96.*



Figure 96

5. Disconnect the electrical connector from the Door Control Panel and set the Panel aside. *Figure 97.*



Figure 97

6. Remove the (3) three 10mm Bolts securing the Door Panel to the Door. *Figure 98.*



Figure 98

7. Grab the bottom part of the Door Panel and pull it to release it from the Door. Slowly pull the entire Door Panel away until it is released.
8. Peel up the Sound Deadening on the side of the Door to provide access to remove the Check Link. *Figure 99.*



Figure 99

9. Remove the (3) three 10mm Bolts that secure the Check Link to the vehicle. *Figure 100.*



Figure 100

10. Remove the Check Link from inside the Door behind the Sound Deadening.

11. Continue to the [TAB CHECK LINK](#) section for Check Link disassembly and Door Stopper Installation.

12. Follow *Steps 2-10* in reverse to reinstall the Door Stopper and Door Panel.

13. Repeat *Steps 2-12* for the other side of the vehicle.

BOLTED CHECK LINK

1. Move the Plate to the middle position of the Check Link Assembly. This is necessary to easily remove the OE Door Stoppers. *Figure 101.*

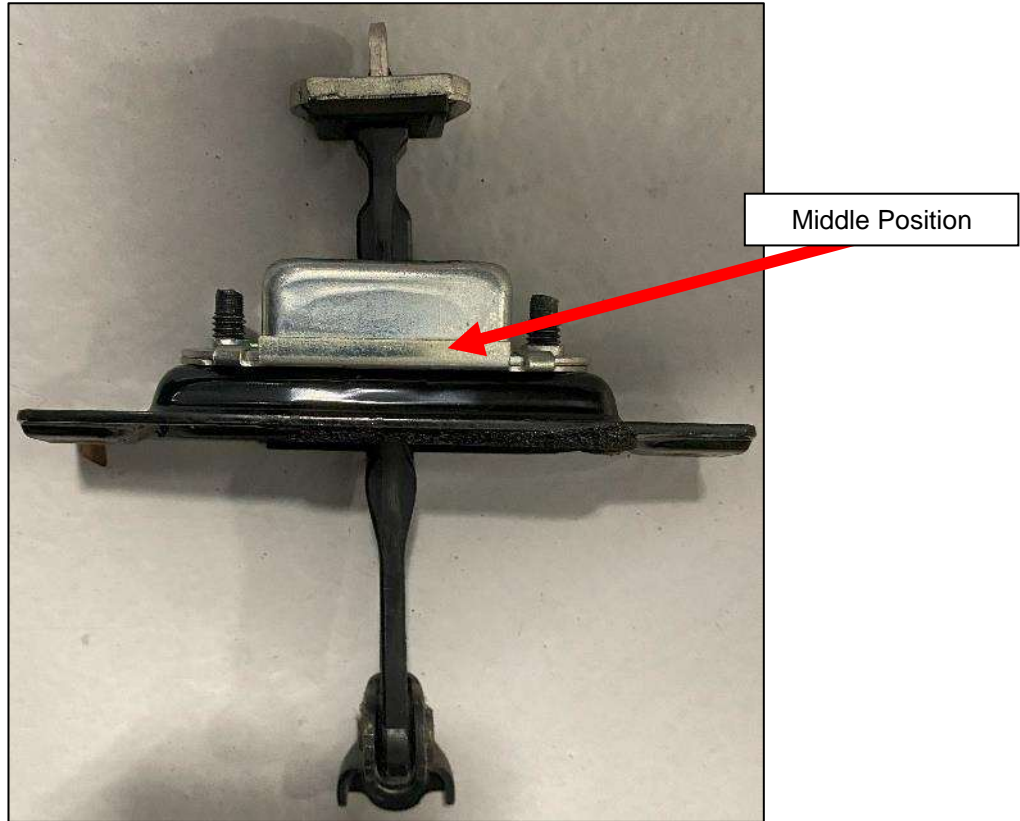

Figure 101

2. Using Pliers, pry up the (4) four tabs that secure the (2) two plates together. *Figure 102.*

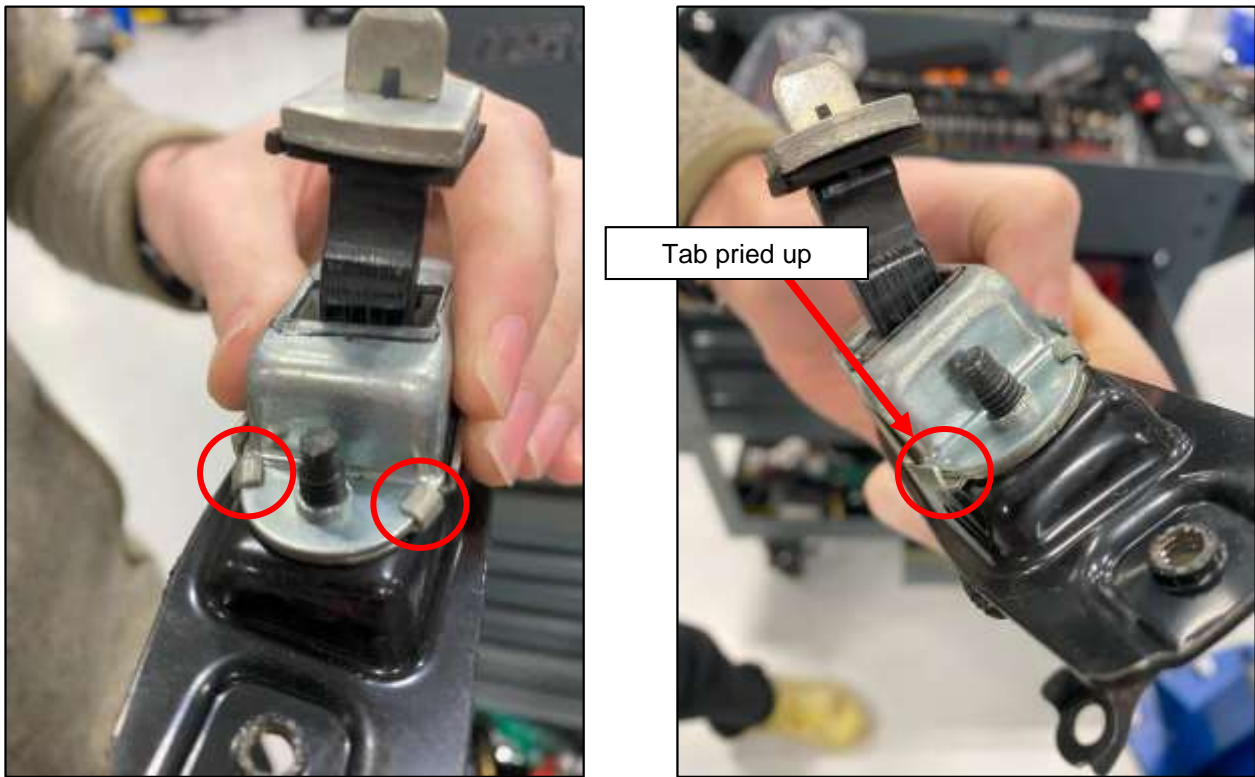

Figure 102

3. Make a note of the Orientation of the Black Plate on the Silver Plate in relation to the Check Link Assembly. It will need to be reinstalled in the same orientation. *Figure 103.*

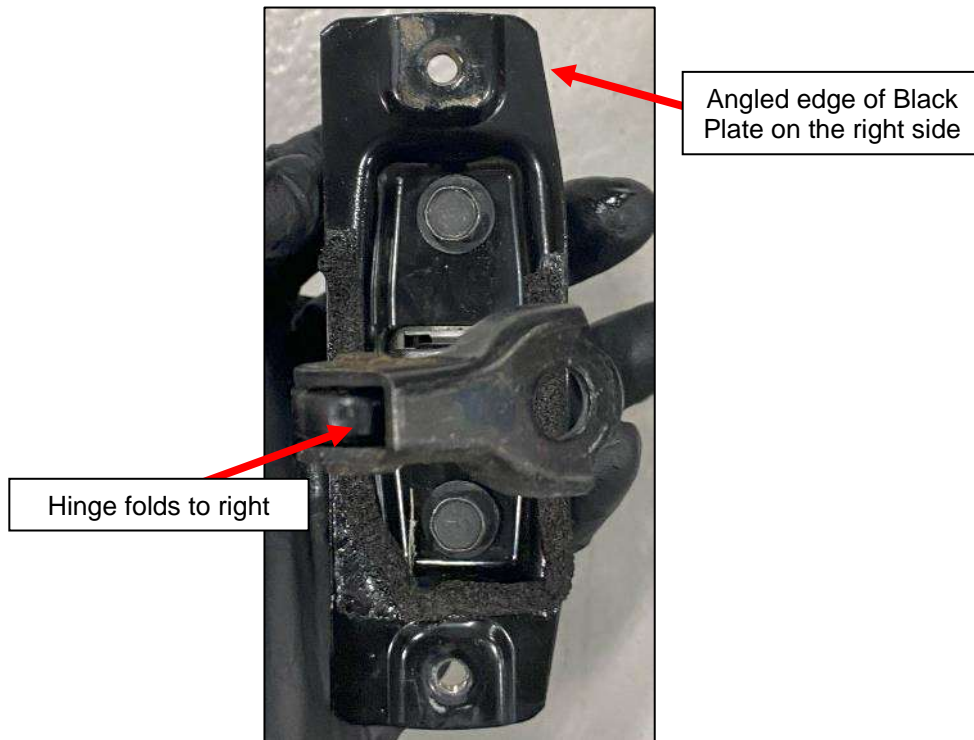

Figure 103

4. Remove the (2) two 10mm nuts that secure the Plate and remove the Black Plate from the Hinge and set aside. Again, make sure to note the Orientation of the Plate for reinstallation. *Figure 104.*

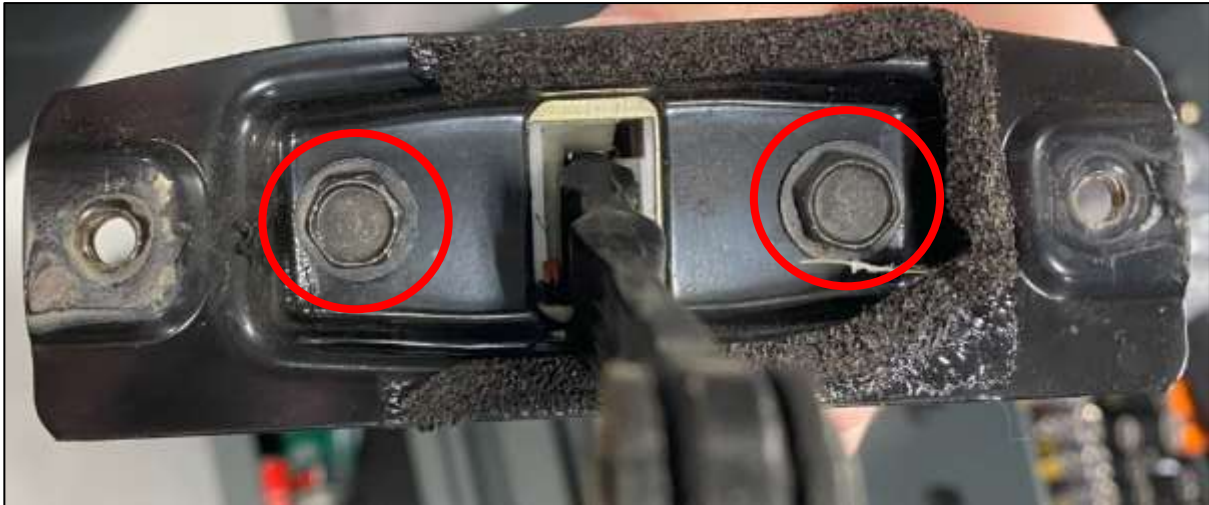

Figure 104

5. Push/pull the Silver Plate towards the back of the Check Link to remove the OE Door Stoppers. *Figure 105.*

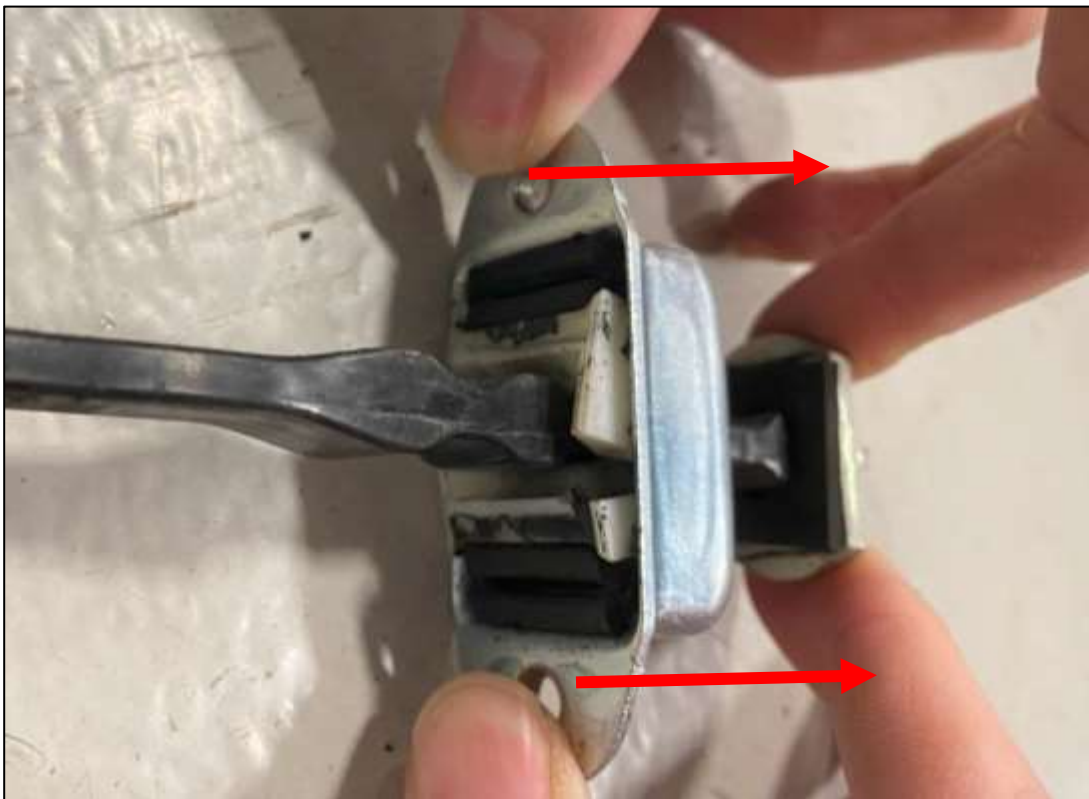

Figure 105

6. Locate (2) two Plastic Guides and (2) two Rubber Bushings. Assemble them as shown below. The nubs in the Rubber Bushings will line up with the holes in the Plastic Guides. The orientation they are shown in is also how they will need to be installed into the Silver Plate. *Figure 106.*



Figure 106

7. Using some Silicone Spray or another equivalent lubricant, lubricate the Rubber Bushings and the inside of the Silver Plate.
8. Orient the Rubber Bushings and Plastic Guides around the Check Link. We found it easiest to position the Rubber Bushings slightly inside of the Silver Plate and push the Plastic Guides into the plate. This is a difficult step and may take a few tries. Ensure the orientation of the Bushings/Guides is the same as below. *Figure 107.*



Figure 107

9. With the Bushings and Guides in, reinstall the Plate and bend the tabs back to secure the Door Stoppers before reinstalling into the vehicle.

TAB CHECK LINK

1. With the Check Link removed, use pliers to bend and open up the (4) four metal tabs that secure the (2) two Check Link Plates together. *Figure 108.*



Figure 108

2. Pull the Silver Plate towards the bottom of the assembly to remove the OE Door Stoppers. *Figure 109.*



Figure 109

3. Locate (2) two Plastic Guides and (2) two Rubber Bushings. Assemble them as shown below. The nubs in the Rubber Bushings will line up with the holes in the Plastic Guides. The orientation they are shown in is how they will need to be installed into the Silver Plate. *Figure 110.*

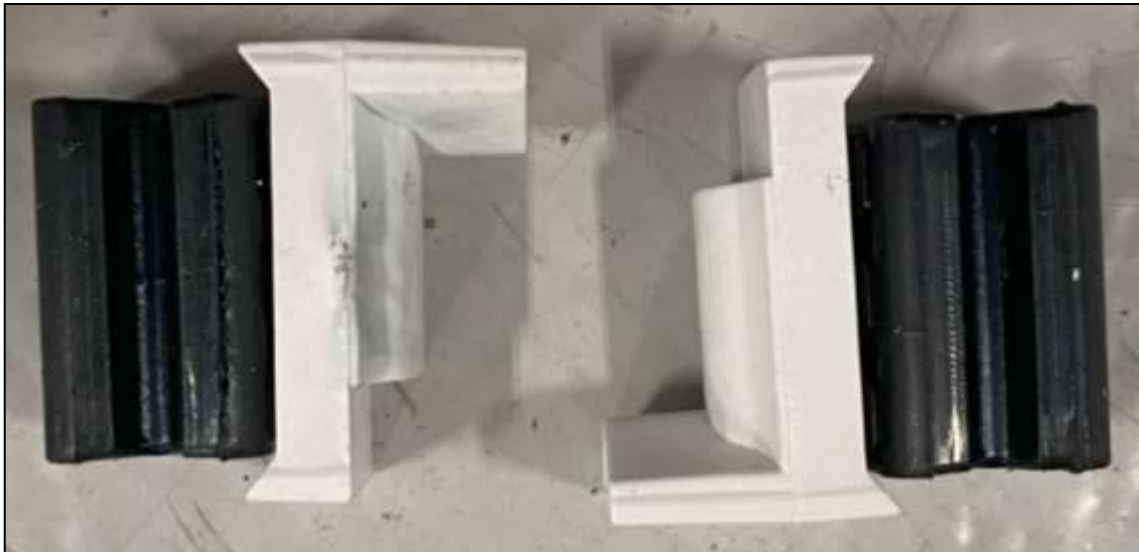

Figure 110

4. Use Silicone Spray or another equivalent lubricant and lubricate the Rubber Bushings and the inside of the Silver Plate.
5. Orient the Rubber Bushings and Plastic Guides around the Check Link. We found it easiest to position the Rubber Bushings slightly inside of the Silver Plate and push the Plastic Guides into the plate. This is a difficult step and may take a few tries. Ensure the orientation of the Bushings/Guides is the same as below. *Figure 111.*



Figure 111

6. Follow *Step 1* in reverse order to reinstall the top plate and bend the tabs back to secure the Door Stoppers before reinstalling into the vehicle.

END

Additional Technical Support:
Contact Z1 Motorsports at info@z1motorsports.com
Or call 770-838-7777 between 9am and 6pm ET