

# Z1 G37 COUPE CARBON FIBER RADIATOR AIR GUIDE INSTALLATION MANUAL

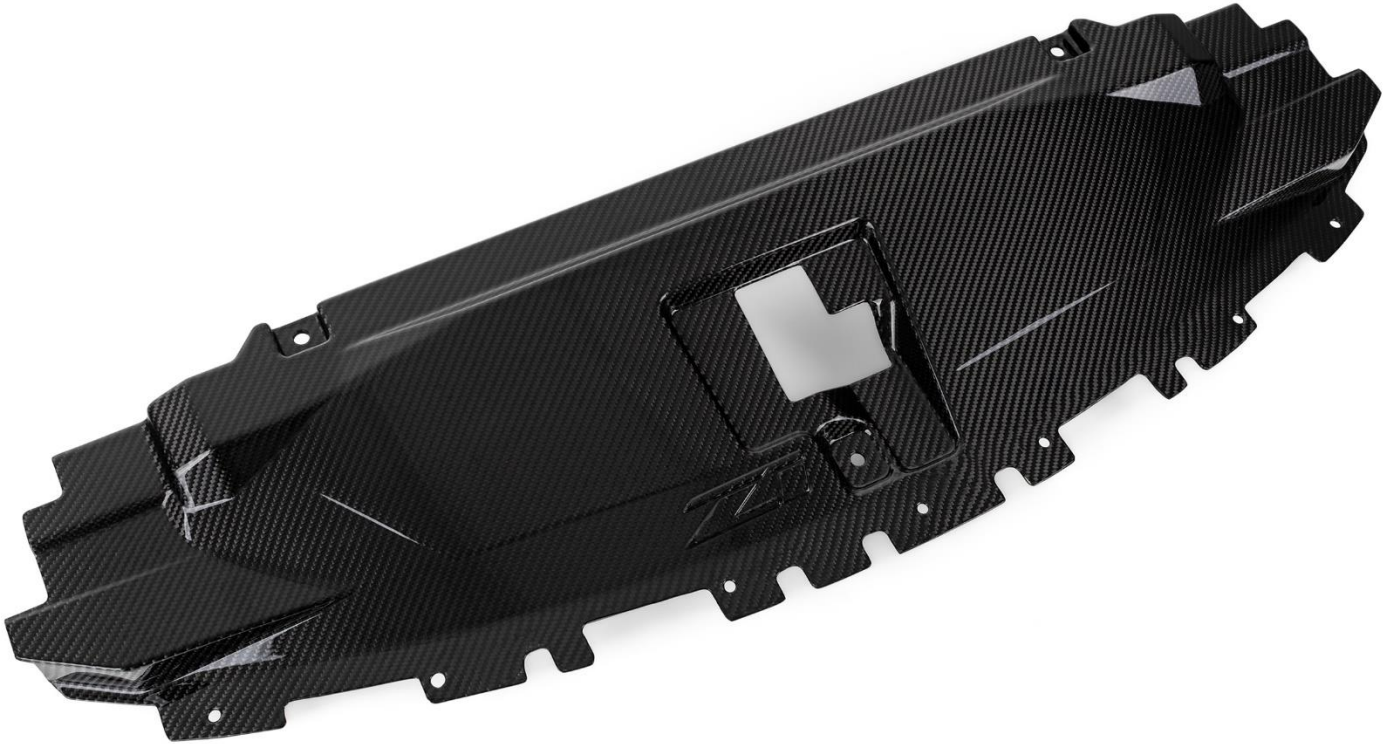

This Installation Manual is intended for the following models:

2008-2015

Infiniti G37 Coupe

## PROLOGUE:

Study these instructions completely before proceeding to assembly. The installer must have a thorough knowledge of automotive systems operation. If unfamiliar with any of the concepts outlined in this instruction, we recommend the installation be completed by a qualified professional.

## WARNING!

Extreme caution should be taken when performing maintenance or performance upgrades to your vehicle. Please observe and abide by any Warning or Caution labels placed on the various components and tools used when servicing your vehicle. If you have any questions regarding installation or the various components included with the Z1 Motorsports G37 Coupe Carbon Fiber Radiator Air Guide, consult with a Professional Mechanic or contact Z1 Motorsports for more information.

## **PARTS INCLUDED:**

Item	Quantity	Description
1	1	G37 Coupe Carbon Fiber Radiator Air Guide

## **TOOLS REQUIRED:**

- Hydraulic Jack
- (2) 2-Ton (or greater) Jack Stands
- Ratchet
- Ratchet Extension(s)
- Assorted Metric Sockets
- Flat-head Screwdriver
- Pliers

## **SAFETY REQUIREMENTS:**

- Always wear safety glasses and any necessary protective garments. If using any fluids, chemicals, or solvents, a respirator is recommended.
- Always turn the ignition to the OFF position and disconnect the NEGATIVE battery terminal.
- Always use properly rated jack stands when working under your vehicle.
- Always keep limbs and parts away from moving drivetrain parts.
- Only operate drivetrain in safe space and well-ventilated areas.

## **BEFORE YOU BEGIN:**

Remove contents from the Z1 Motorsports G37 Coupe Carbon Fiber Radiator Air Guide and verify that ALL necessary hardware is present.

## **PROCEDURE:**

The radiator air guide on G37 coupes is easiest and safest to remove with the front bumper removed from the vehicle. You can remove the air guide without removing the bumper but risk breaking some plastic clips and/or damaging the front bumper.

1. Place the transmission in Park position (or in Reverse gear if equipped with a manual transmission). Apply the parking brake.
2. Locate proper jacking points on vehicle's chassis (refer to vehicle's Owner Manual). Raise and support vehicle using jack & jack stands.

G37 Owners: Use the diagram below as reference for steps # 3 - 7.

3. Remove the lower engine splash shield (undershroud). Fasteners will be an assortment of 10mm screws and plastic panel clips. Use a flat blade screwdriver to gently pry up the pop clips.

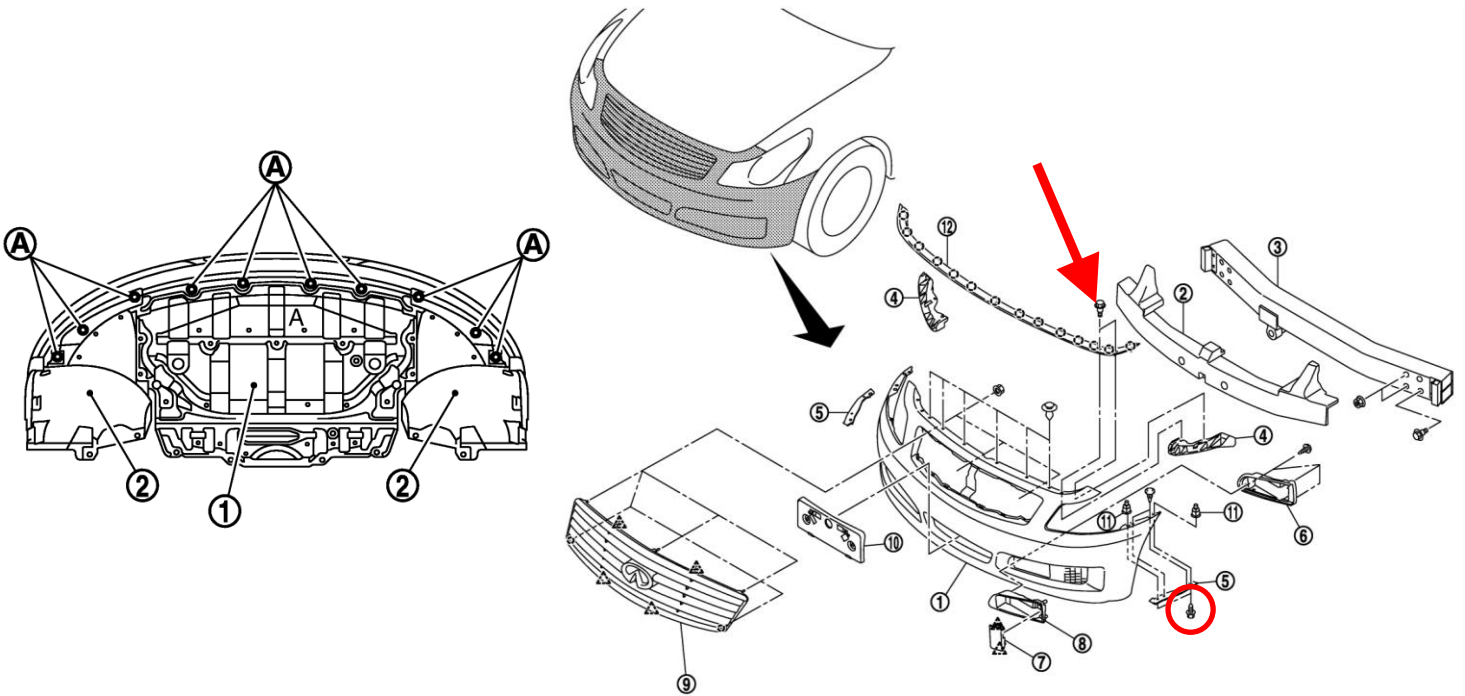

4. Remove plastic clips and remove the front wheel/fender liners to reveal (2) mounting screws at each side of vehicle which mounts corner of bumper fascia to the fender (screw circled in diagram above). Remove mounting screws on each side.
5. Lift up on the hood seals at the front corner of the engine bay to reveal (2) mounting screws at each side of vehicle that mounts the upper corner of bumper fascia to the fender (screw shown with arrow above). Remove mounting screws on each side.
6. Remove (6) plastic pop clips securing upper of bumper fascia to vehicle at radiator core support.
7. With a light pull motion, carefully disengage bumper fascia from clips on vehicle just below each headlight. Remove bumper fascia and set aside.
8. Remove the ~8 10mm bolts securing the air guide to the radiator core support. The bumper is still on in the image below.

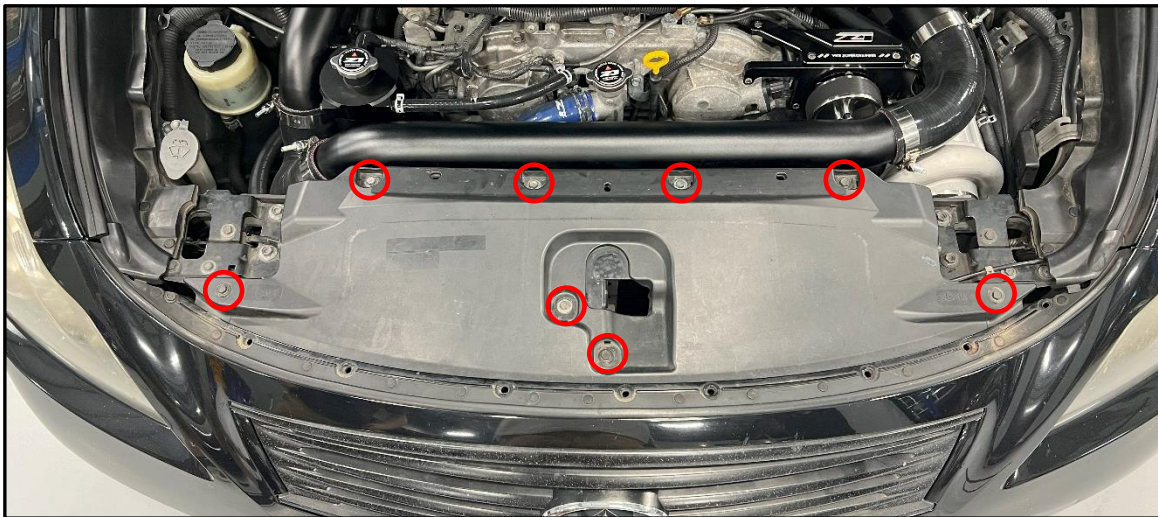

9. Once disconnected, lift up on the rear of the OE air guide to get access to the wiring harness clips on the underside of the panel. Use pliers to pinch the clips and disconnected them from the air guide (shown with arrows below).



10. Then go to the front of the panel and disconnect the hood latch cable. They are square white clips and shown with circles above.
11. Once the wiring harness and hood latch cable have been disconnected, fully remove the OE air guide.
12. Locate the Z1 carbon fiber air guide. Connect the hood latch cable and wiring harness clips to the holes on the lip on the underside of the Z1 air guide. The image below shows the hood latch cable's white clips already installed.



13. With the wiring harness and hood latch cables attached, reinstall (3) 10mm screws that were removed in step # 8, securing the Z1 carbon air guide in place. Because of the rigidity of the carbon fiber piece, the Z1 panel does not need to utilize all 8 bolts.
14. If removed, follow steps # 3-7 in reverse order to reinstall the front bumper.
15. Completed installation of the Z1 G37 Coupe Carbon Fiber Radiator Air Guide should look as shown below.



16. Properly remove vehicle from jack and jack stands.
17. Check vehicle for loose tools/items.
18. Take vehicle for a final test drive.

**END**

**Additional Technical Support:**  
Contact Z1 Motorsports at [info@z1motorsports.com](mailto:info@z1motorsports.com)  
Or call 770-838-7777 between 9am and 6pm ET