

Z1 G37 STEERING WHEEL HUB ADAPTOR INSTALLATION MANUAL



This Installation Manual is intended for the following models:

2008-2015	Infiniti G37 (Coupe)
2009-2015	Infiniti G37 (Sedan)
2007-2008	Infiniti G35 (Coupe)

PROLOGUE:

Study these instructions completely before proceeding to assembly. The installer must have a thorough knowledge of automotive systems operation. If unfamiliar with any of the concepts outlined in this instruction, we recommend the installation be completed by a qualified professional.

WARNING!

Extreme caution should be taken when performing maintenance or performance upgrades to your vehicle. Please observe and abide by any Warning or Caution labels placed on the various components and tools used when servicing your vehicle. If you have any questions regarding installation or the various components included with the Z1 Motorsports G37 Steering Wheel Hub Adaptor, consult with a Professional Mechanic, or contact Z1 Motorsports for more information.

PARTS INCLUDED:

Item	Quantity	Description
1	1	Steering Wheel Hub Adaptor
2	2	Airbag Resistor

TOOLS REQUIRED:

- Ratchet
- Ratchet Extension(s)
- Assorted Metric Wrenches
- Assorted Metric Sockets
- Torque Wrench
- TORX Tamper Resistant T30 Bit
- Impact Gun (Recommended)
- Steering Wheel Puller (Recommended)
- Flat Head Screwdriver
- Electrical Tape

SAFETY REQUIREMENTS:

- Always wear safety glasses and any necessary protective garments. If using any fluids, chemicals, or solvents, a respirator is recommended.
- Always turn the ignition to the OFF position and disconnect the NEGATIVE battery terminal.
- Always use properly rated jack stands when working under your vehicle.
- Always keep limbs and parts away from moving drivetrain parts.
- Only operate drivetrain in safe space and well-ventilated areas.

BEFORE YOU BEGIN:

Remove contents from the Z1 Motorsports G37 Steering Wheel Hub Adapter and verify that ALL necessary hardware is present.

PROCEDURE:

1. Place the transmission in Park position (or in Reverse gear if equipped with a manual transmission). Apply the parking brake.
2. Open and support the hood of the Vehicle.
3. Turn the Steering Wheel until the wheel and wheels are straight.
4. Disconnect the (-) **NEGATIVE** battery terminal.
5. Let the car sit for half an hour, this will allow all power to drain out to prevent the Airbag from potentially going off.
6. Remove the (2) two Covers hiding the (2) two bolts securing the Airbag to the Steering Wheel. *Figure 1.*
7. Remove the (2) two bolts securing the Airbag to the Steering Wheel. These need a [TORX T30 Bit](#). It is recommended to replace these bolts after removal. *Figure 1.*

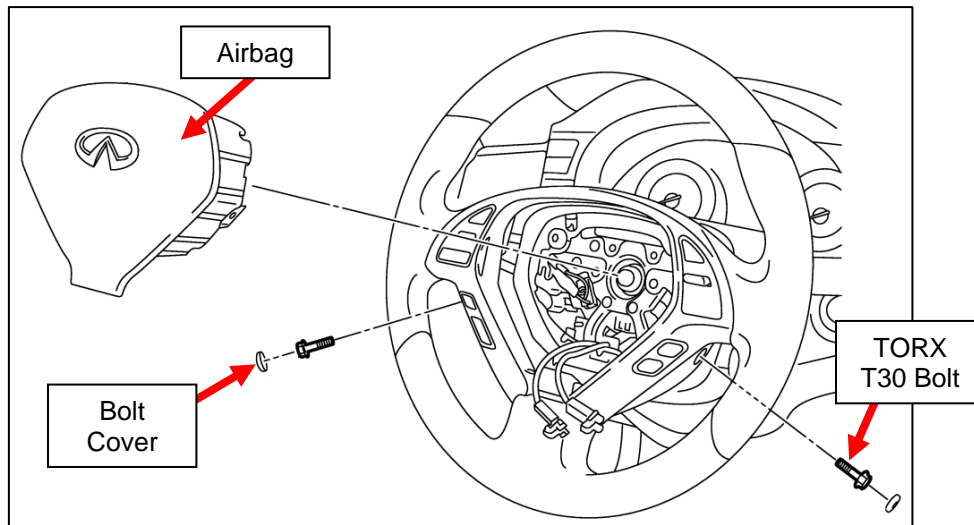

Figure 1

8. Remove the Airbag from the Steering Wheel, it is held on by (2) two connectors. Disconnect them and remove the Airbag. *Figure 2.*



Figure 2

NOTE: The connectors have a small clip that must be pushed upwards to remove. *Figure 3.*

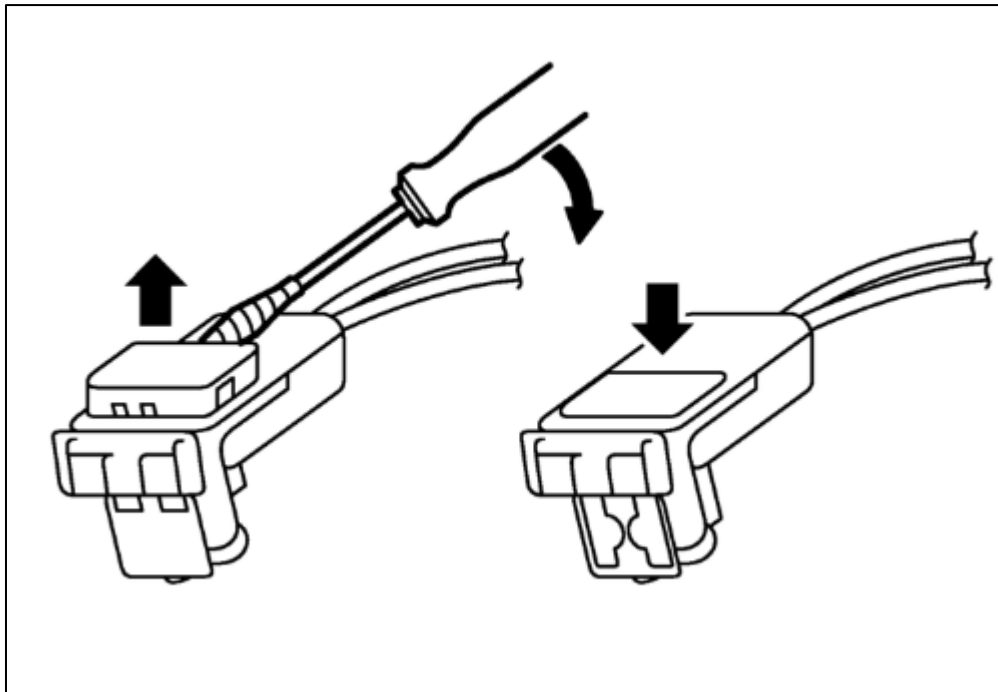

Figure 3

9. Disconnect the Horn Connector and the Gray Connector for the Button Controls on the Steering Wheel.
Figure 4.

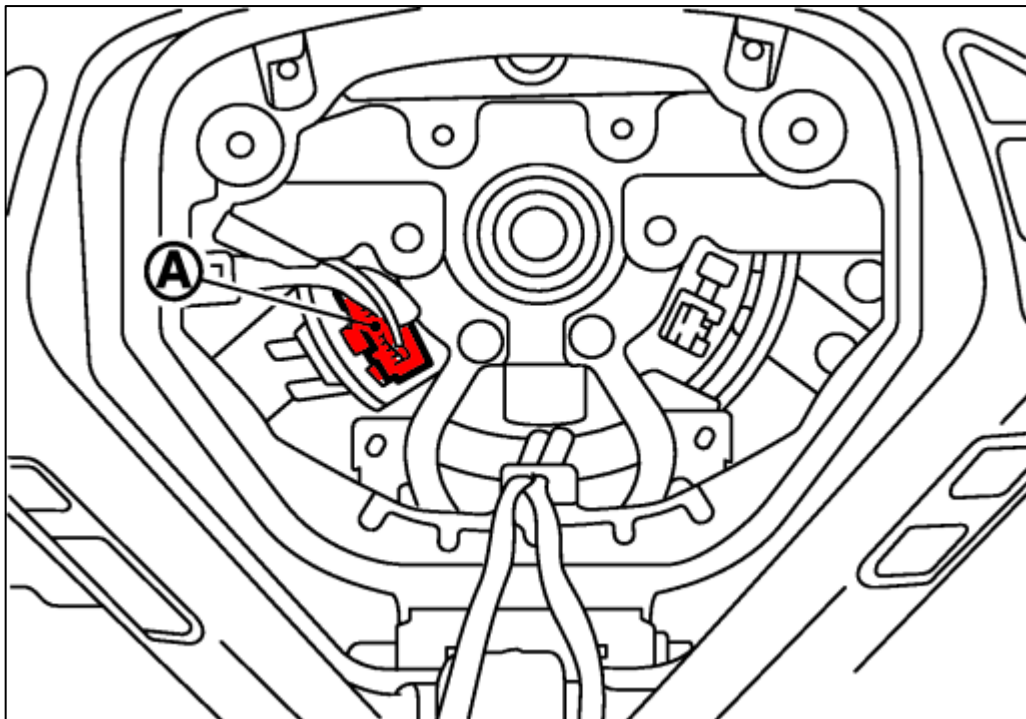

Figure 4

10. Using an impact gun, remove the nut in the center of the Steering Wheel. *Figure 5.*

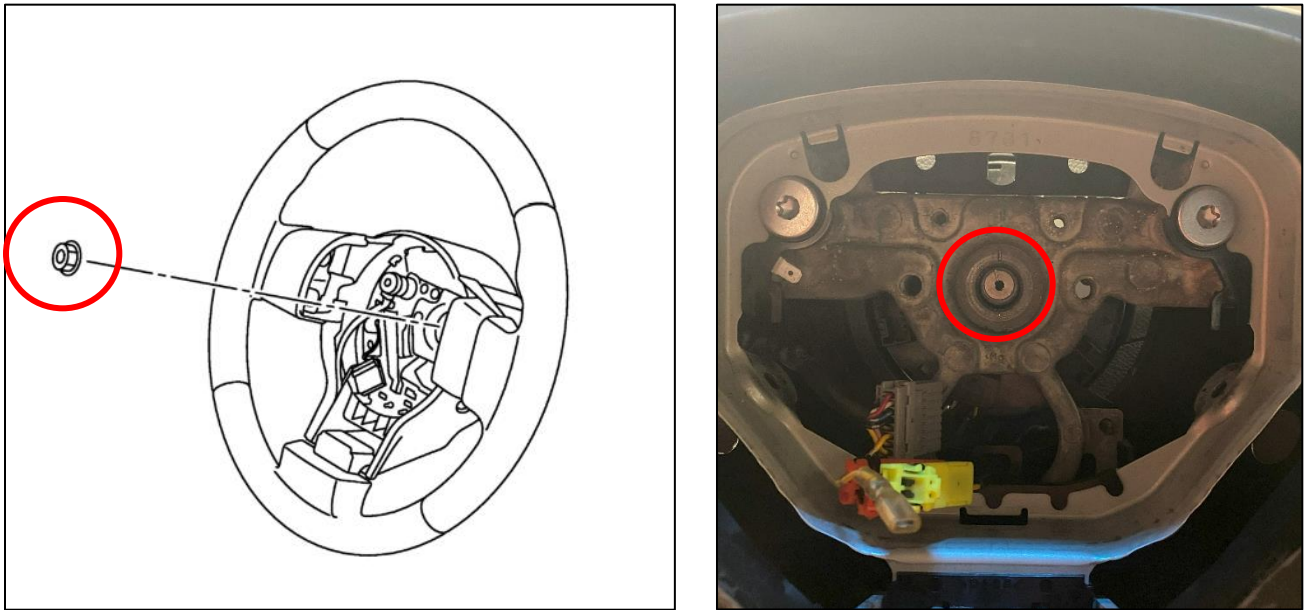

Figure 5

11. Using a Steering Wheel Puller, remove the OE Steering Wheel. If you do not have a Steering Wheel Puller, grab the Steering Wheel at the top and bottom, and rock the wheel back and forth to loosen it. *Figure 6.*

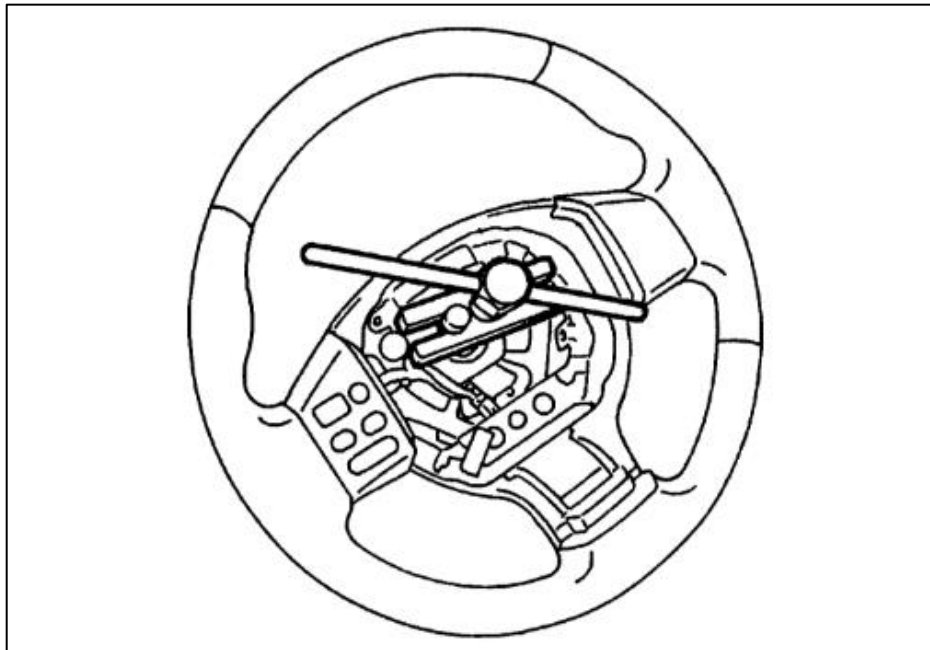

Figure 6

NOTE: If you are using the Z1 G37 Steering Wheel Button Control Bracket, use the instructions [HERE](#) for installation.

12. Reconnect the Steering Wheel Button Controls and the Horn Connector back onto the Wheel Hub if applicable.
13. Place the Z1 Steering Wheel Hub Adaptor place it on the Steering Shaft. Line up the mark on the Steering Shaft with the mark on the Z1 Steering Wheel Hub Adapter. Feed the Horn Wire and the Button Control Wire through the openings if you are using them. *Figure 7.*

NOTE: The images below are from a 350Z, but the process is still the same.

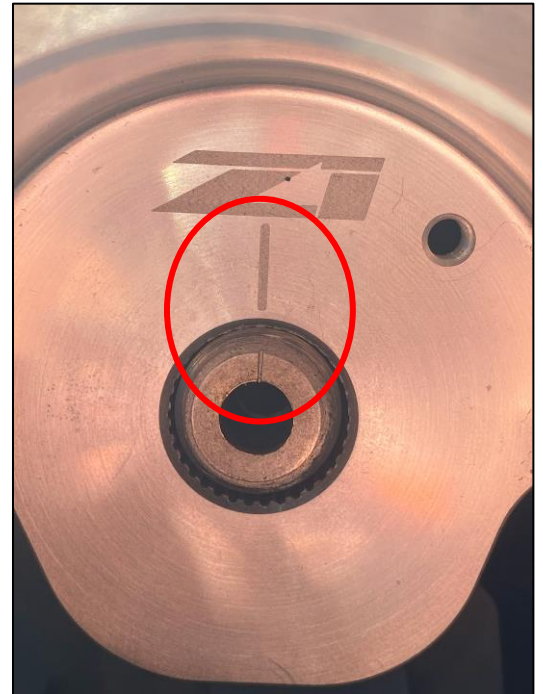

Figure 7

14. Reinstall the OE Nut removed in Step 10 to the Steering Shaft. Torque to **25 ft-lbs.** Figure 8.

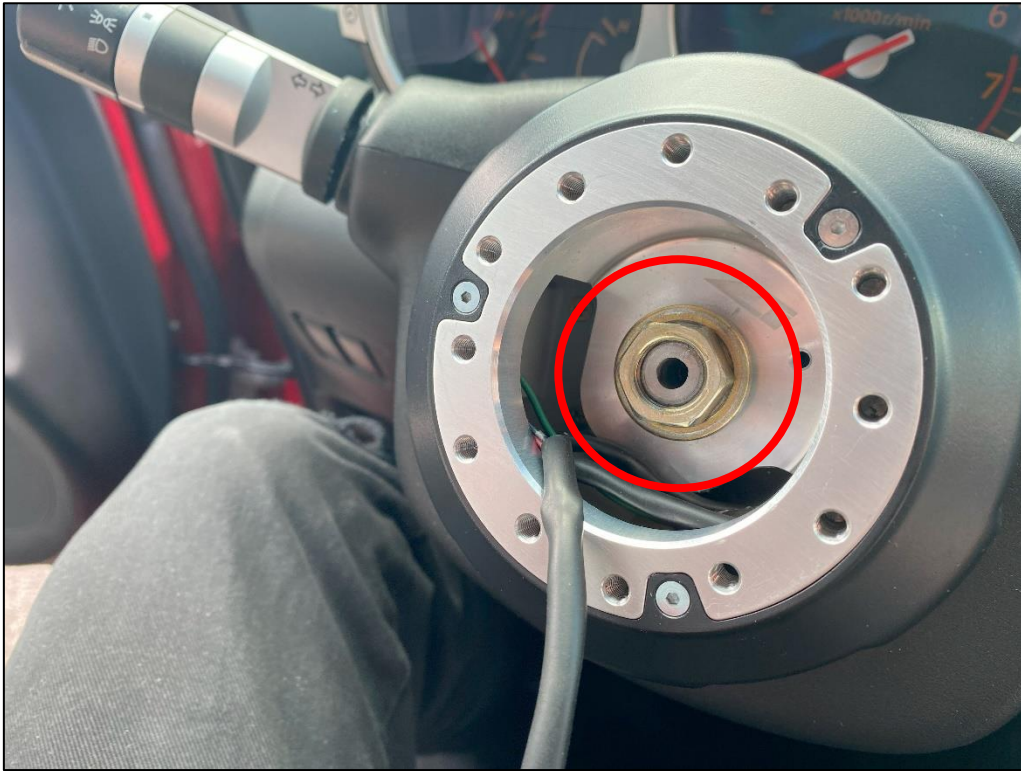

Figure 8

15. Locate the (2) two Airbag Resistors. Plug (1) one into each Airbag Connector removed in *Step 8*. These will prevent the car from throwing an Airbag Code. Wrap the Connectors and Resistors with electrical tape to secure them and tuck them into the Steering Hub. *Figure 9*.

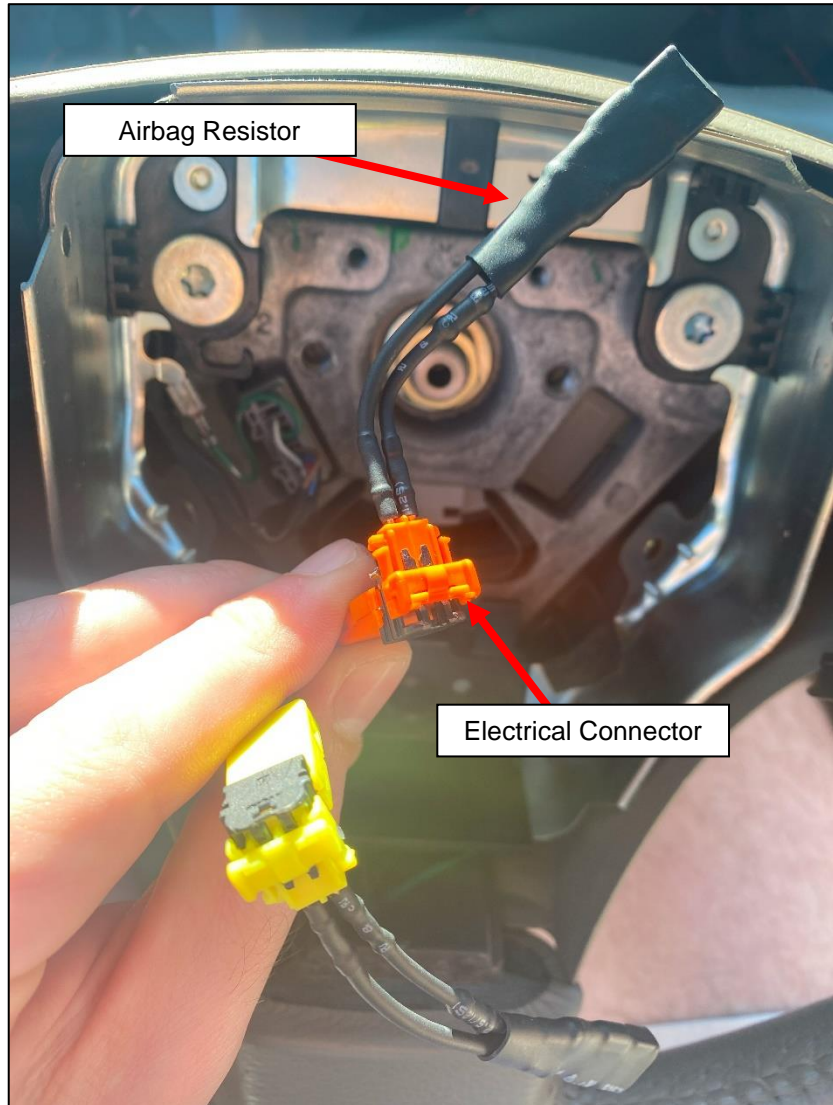

Figure 9

16. Your Z1 Steering Wheel Hub Adaptor is now installed, if you are using any of the following products, follow the instructions included with them below:

- [G37 Steering Wheel Control Bracket](#)
- [Z1 Steering Wheel Quick Release](#)
- [Z1 Steering Wheel Spacer](#)

END

Additional Technical Support:
Contact Z1 Motorsports at info@z1motorsports.com
Or call 770-838-7777 between 9am and 6pm ET