

## Z1 Q50 / Q60 TRACTION ARMS INSTALLATION MANUAL



This Installation Manual is intended for the following models:

2014+	Infiniti Q50
2017+	Infiniti Q60

### PROLOGUE:

Study these instructions completely before proceeding to assembly. The installer must have a thorough knowledge of automotive systems operation. If unfamiliar with any of the concepts outlined in this instruction, we recommend the installation be completed by a qualified professional.

### WARNING!

Extreme caution should be taken when performing maintenance or performance upgrades to your vehicle. Please observe and abide by any Warning or Caution labels placed on the various components and tools used when servicing your vehicle. If you have any questions regarding installation or the various components included with the Z1 Motorsports Q50 / Q60 Traction Arms, consult with a Professional Mechanic or contact Z1 Motorsports for more information.

## **PARTS INCLUDED:**

Item	Quantity	Description
1	1	Loctite 271 – 0.5ml
Note: Street Version Traction Arms will provide the following:		
2	2	Pre-assembled traction arm with urethane bushing assembly
Note: Race Version Traction Arms will provide the following:		
3	2	Pre-assembled traction arm with solid heim joint assembly

## **TOOLS REQUIRED:**

- Hydraulic Jack
- (2) 2-Ton (or greater) Jack Stands
- Wheel Chock
- Ratchet
- 17mm Socket
- 19mm Socket
- 17mm Wrench
- 19mm Wrench
- Crescent Wrench
- Torque Wrench

## **SAFETY REQUIREMENTS:**

- Always wear safety glasses and any necessary protective garments. If using any fluids, chemicals, or solvents, a respirator is recommended.
- Always use properly rated jack stands when working under your vehicle.
- Always keep limbs and parts away from moving drivetrain parts.
- Only operate drivetrain in safe space and well-ventilated areas.

## **BEFORE YOU BEGIN:**

Remove contents from the Z1 Motorsports Q50 / Q60 Traction Arms and verify that ALL necessary hardware is present.

## **PROCEDURE:**

1. Assure the car's ignition is in the OFF position and the NEGATIVE (-) battery terminal is disconnected.
2. Place the transmission in Park position (or in Reverse gear if equipped with a manual transmission). Apply the parking brake.
3. Release tension to lug nuts at rear wheels. DO NOT remove lug nuts!
4. Locate proper jacking points on vehicle's chassis (refer to vehicle's Owner Manual). Raise and support vehicle using jack & jack stands.
5. Remove lug nuts and rear wheel.
6. Locate OEM traction arms located at left & right, connecting rear knuckle to sub-frame (as shown).
7. Remove bolt that attaches OEM traction arm to sub-frame.
8. Remove bolt that attaches OEM traction arm to rear knuckle.
9. Remove OEM traction arm from vehicle.

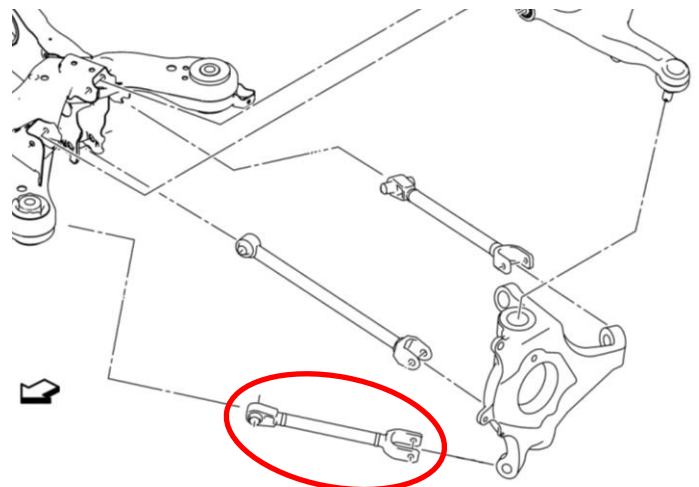

10. Locate Z1 traction arms. Thread each end completely inside body. Set Z1 traction arm next to OEM traction arm and adjust length to match (343mm from eye-to-eye)

Note: Assure exposed threads at each end does not exceed 15mm.

Note: Assure that ends remain stationary while body is rotated.



**Pro Tip!**

If you have two long bolts available, slide them through the OEM traction arm and adjust Z1 traction arm so it can slide on the same bolts. This will guarantee the mounting holes are the exact same width.

11. Once length is set, apply red thread locker to exposed threads nearest to control arm. Thread jam nut over thread locker and tighten against control arm.

12. Position Z1 traction arm into sub-frame. Install bolt and torque to 65ft-lbs.

Note: If equipped with street version bushings, assure serviceable grease fittings face downwards.

<p><u>Note:</u> Z1 street version traction arms come equipped with serviceable grease fittings. It is recommended that you add grease after installation and every 5,000 miles to assure long product life. Z1 recommends use of Energy Suspension Formula 5 Prelube or other synthetic water-resistant marine-grade grease.</p>
--

13. Position Z1 traction arm fork onto mounting hole of rear knuckle. Install bolt and torque to 65ft-lbs.

14. Install rear wheel and lug nuts

15. Repeat steps 6-14 for opposite side of vehicle.

16. Properly lower vehicle from jack stands.

17. Torque lug nuts to 80ft-lbs.

18. Perform alignment check & adjust traction arms accordingly.

19. Perform a final test drive of vehicle.

**END**

**Additional Technical Support:**

Contact Z1 Motorsports at [info@z1motorsports.com](mailto:info@z1motorsports.com)

Or call 770-838-7777 between 9am and 6pm ET