

Z1 QX50 COLD AIR INTAKE KIT INSTALLATION MANUAL



This Installation Manual is intended for the following models:

2014-2017

Infiniti QX50

PROLOGUE:

Study these instructions completely before proceeding to assemble. The installer must have a thorough knowledge of automotive systems operation. If unfamiliar with any of the concepts outlined in this instruction, we recommend the installation be completed by a qualified professional.

WARNING!

Extreme caution should be taken when performing maintenance or performance upgrades to your Vehicle. Please observe and abide by any Warning or Caution labels placed on the various components and tools used when servicing your Vehicle. If you have any questions regarding installation or the various components included with the Z1 Motorsports QX50 Cold Air Intake Kit, consult with a Professional Mechanic or contact Z1 Motorsports for more information.

PARTS INCLUDED:

Item	Quantity	Description
1	1	2.5" Intake – Driver Side
2	1	2.5" Intake – Passenger Side
3	1	Silicone L-Hose – Driver Side
4	1	Silicone L-Hose – Passenger Side
5	2	Silicone Straight Reducer Hose
6	1	PCV Breather Hose – Driver Side
7	1	PCV Breather Hose – Passenger Side
8	2	Z1 Air Filter
9	10	HD Hose Clamp, 2-1/3" to 3-1/4"
10	2	1/4" Washer
11	2	Air Filter Union
12	2	M6 Washer

TOOLS REQUIRED:

- Ratchet
- Ratchet Extension
- Hydraulic Jack
- (2) 2-Ton (or greater) Jack Stands
- Pliers
- Needle Nose Pliers
- 8mm Nut Driver
- 10mm Wrench/Socket
- 14mm Wrench/Socket
- Silicone Spray
- Flat-head Screwdriver
- Phillips-head Screwdriver

SAFETY REQUIREMENTS:

- Always wear safety glasses and any necessary protective garments. If using any fluids, chemicals, or solvents, a respirator is recommended.
- Always use properly rated jack stands when working under your Vehicle.
- Always keep limbs and parts away from moving drivetrain parts.
- Only operate drivetrain in safe space and well-ventilated areas.

BEFORE YOU BEGIN:

Remove contents from the Z1 Motorsports QX50 Cold Air Intake Kit and verify that ALL necessary hardware is present.

PROCEDURE:

1. Place the transmissions in Park position (or in Reverse gear if equipped with a manual transmission). Apply the parking brake.
2. Locate proper jacking points on vehicle's chassis (refer to vehicle's Owner Manual). Raise and support vehicle using jack & jack stands.
3. Unlatch and support the hood of the vehicle.
4. Disconnect the **NEGATIVE (-)** battery terminal.

NOTE: Use *Figure 1* below as reference for *Steps 5-13*. The vehicle shown is a 370Z, but the process is the same. QX50 owners will not have a Strut Bar to remove.

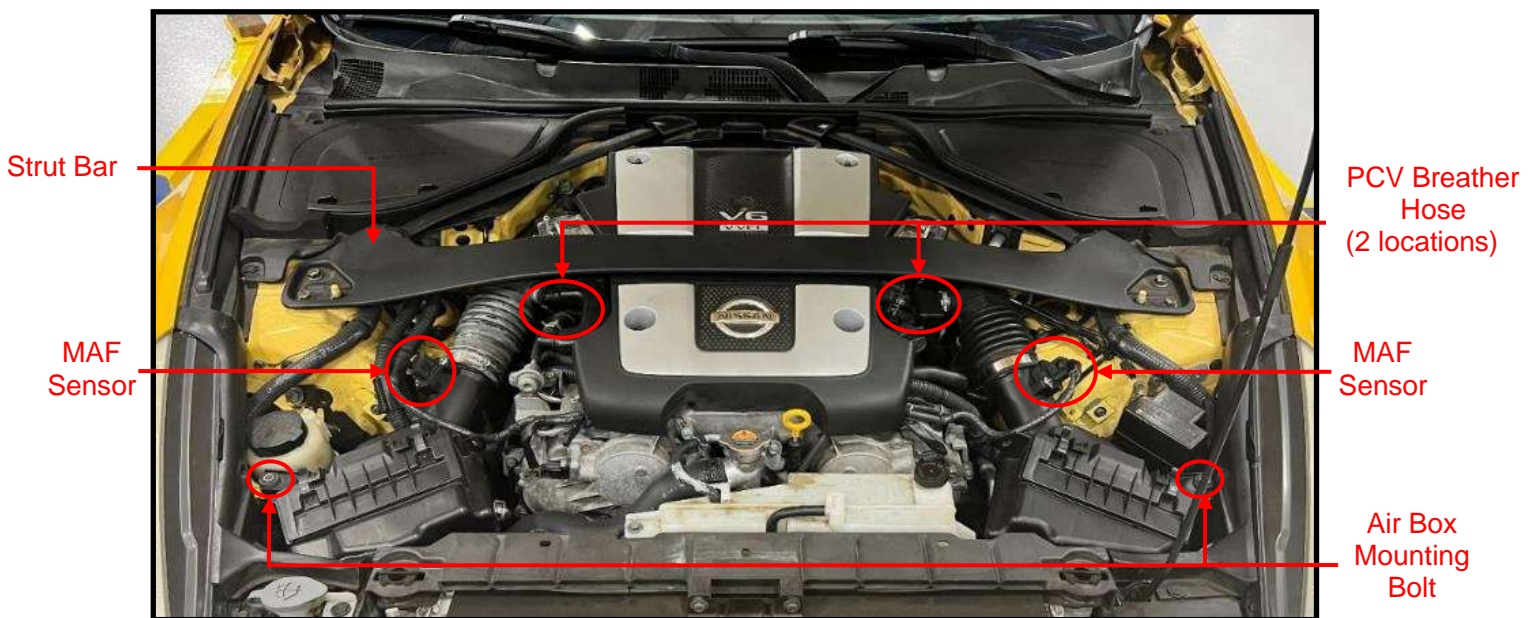

Figure 1

5. Remove the (4) four bolts securing the Engine Cover and remove the Engine Cover.
6. Locate and unplug (2) two MAF sensor connectors as well as their plastic harness clips.
7. Remove (2) two acorn nuts and (2) two bolts which attach the Engine Cover to the engine. Remove Engine Cover and set aside.
8. Remove (1) one bolt which attaches passenger side Intake Canister to Intake Plenum.
9. Using pliers, loosen and pull the OEM PCV Breather hoses at the ends of the Valve Covers.
10. Loosen hose clamps at each Throttle Body.
11. Remove (2) two bolts on each OEM Airbox that mount them to the chassis.
12. Remove plastic clip and (1) one 10mm bolt on each side that attaches the Air Inlet Duct to the Composite Radiator Core Support near each OEM air box opening. Remove Air Intake Ducts.
13. Using a light pull motion, loosen OEM Airboxes from vehicle.
14. The complete OEM Air Intake assembly should be loose at this point. Remove Intake Boxes, hoses, and Intake Balancing hose from vehicle, as shown below in *Figure 2*.



Figure 2

15. Remove the clips securing the Hood Lock Cover to the Core Support and remove the Hood Lock Cover.
Figure 3.

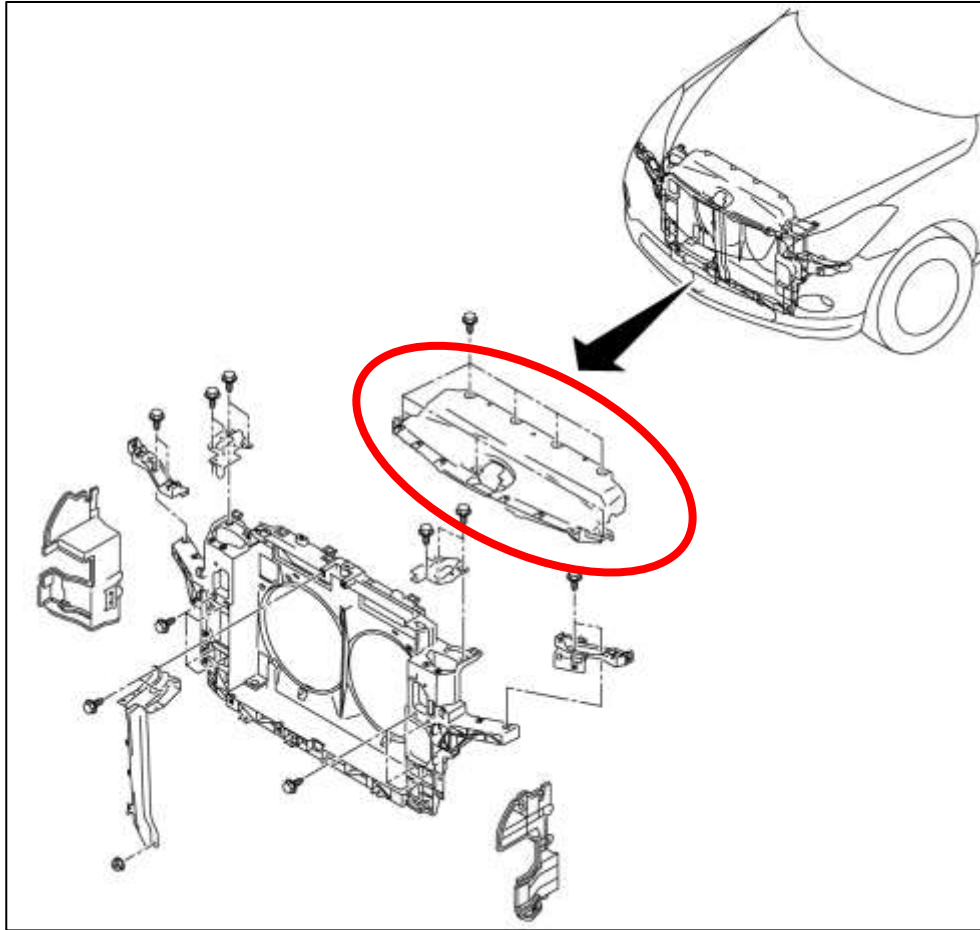

Figure 3

16. Locate (2) two Silicone Reducers and (2) two Hose Clamps. Position a Silicone Reducer and a loose Hose Clamp over each Throttle Body. Once positioned, tighten the Hose Clamps. *Figure 4.*



Figure 4

17. Locate (2) two Air Filters, (2) two Air Filter Unions, and (2) two Hose Clamps. Insert the barbed side of the Air Filter Union into each Air Filter. Position a Hose Clamp over each Air Filter and tighten. *Figure 5.*



Figure 5

18. Locate (2) two Z1 PCV Breather Hoses. Transfer the (4) four OE Clamps from the OE Air Intake Assembly onto the Z1 PCV Hoses. Position the Z1 Hoses with clamps over each Valve Cover nipple. *Figure 6.*



Figure 6

19. Remove the (2) two bolts which mount each MAF Sensor to the OEM Air Intake Assembly. Transfer the MAF Sensors and bolts to the MAF Sensor Mounting Boss of Z1 Air Intake Pipes. Tighten mounting bolts.

NOTE: Be sure to install the MAF Sensor onto the Air Intake Pipe facing the same direction removed from OE Air Intake Box. There is an arrow on each MAF Flange showing the direction of airflow.

20. Locate the Driver Side Air Intake Pipe and a Hose Clamp. There is a Left and Right Intake Pipe. The MAF Sensor should be on the bottom side of the Air Intake Pipes, with the arrow showing the direction of airflow pointing towards the Throttle Bodies. Position the Loose Clamp over the Silicone Throttle Body Reducer and slide in the Air Intake Pipe. Do not tighten the Hose Clamp at the Reducer yet.

NOTE: Use of Silicone Spray or another dissolvable lubricant is recommended for all assembly which involves Silicone Reducers or Hoses.

21. Position the Driver Side PCV Breather Hose over Air Intake Pipe nipple. Slide and tighten the OEM Hose Clamp over nipple.
22. Disconnect the Upper Driver Side Horn and remove the Mounting Bolt securing the Horn to the Core Support. *Figure 7.*

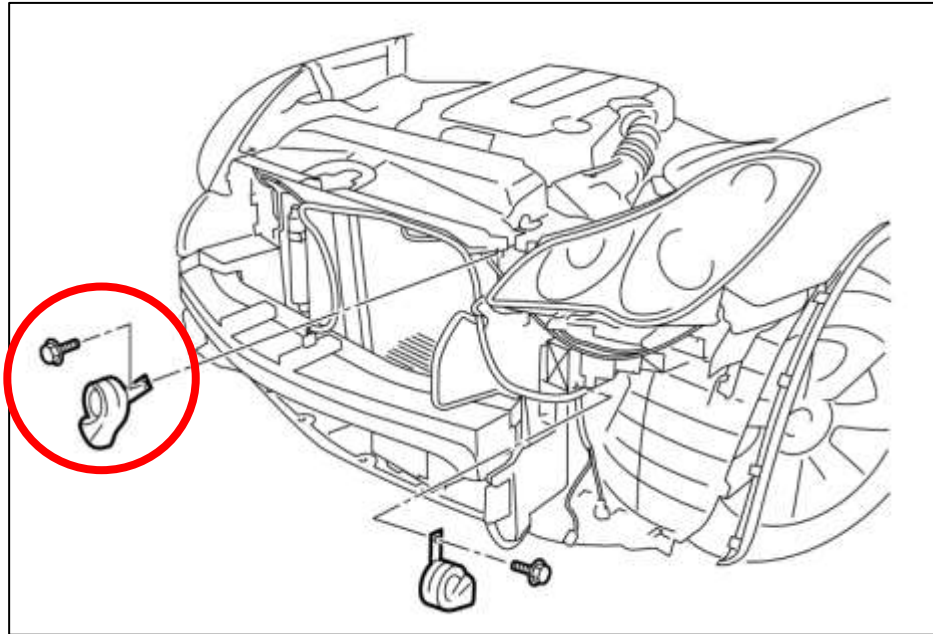

Figure 7

23. Locate the Driver Side Silicone L-Hose. To differentiate the Driver and Passenger L-Hoses, when oriented with the Z1 logo on top, the longer side will have a slight bend towards the Throttle Bodies. The Passenger side will form an “L” and the Driver side will form a “**Backwards L.**” Insert the L-Hose through the Radiator Core Support on the Driver Side.

NOTE: Silicone Hose will conform to the profile of the through hole, however removing material from Radiator Core Support is advised for optimal performance. Removal of the Front Bumper will be required if you desire to clearance the Core Support.

24. Once through the Core Support, position a loose Hose Clamp over the Silicone L-Hose and install it onto the Air Intake Pipe. Do not tighten the Hose Clamp yet.
25. Place a loose Hose Clamp over the Silicone Hose exposed at the front of the vehicle.
26. Locate an Air Filter & Union Assembly. Insert the exposed end of the Union into the silicone hose at the front of the vehicle. Tighten the Hose Clamp over the Hose and Union.
27. Adjust the Silicone Reducer, Air Intake Pipe, and Silicone L-Hose to relieve any structural stresses. Once adjusted, tighten the Hose Clamps located at the Throttle Body and at the Silicone L-Hose and Air Intake Pipe.
28. Plug MAF Sensor Harness back into the MAF Sensor.

29. Locate (2) two M6 Washers. Position them on the back of the Mounting Bolt for the Horn that was removed in *Step 21*. Reinstall the Horn Bracket and the Horn Connector. Clock the Horn to avoid contact with the Air Intake Pipe and tighten the Bracket bolt once adjusted. *Figure 8*.



Figure 8

30. Repeat *Steps 19-27* for the Passenger Side Air Intake Pipe. Skip *Step 21* as the horn does not affect the Passenger Side.
31. Follow *Steps 5-21* in reverse order to reinstall the Front Bumper Fascia and other Engine Bay parts.

NOTE: You will have (2) two remaining M6 Bolts that are not needed. They are used in the G37/350Z Cold Air Intake Kit but are not necessary for this installation.

32. Properly lower vehicle from jack stands.
33. Inspect vehicle for loose tools/items.
34. Start vehicle. While at idle, check for leaks or faulty operation of the Air Intake Kit.
35. Lower hood of vehicle.
36. Perform a final test drive of the vehicle.

END

Additional Technical Support:
Contact Z1 Motorsports at info@z1motorsports.com
Or call 770 838 7777 between 9am and 6pm ET