

Z1 STEERING WHEEL AIRBAG DELETE RESISTORS INSTALLATION MANUAL



PROLOGUE:

Study these instructions completely before proceeding to assembly. The installer must have a thorough knowledge of automotive systems operation. If unfamiliar with any of the concepts outlined in this instruction, we recommend the installation be completed by a qualified professional.

WARNING!

Extreme caution should be taken when performing maintenance or performance upgrades to your vehicle. Please observe and abide by any Warning or Caution labels placed on the various components and tools used when servicing your vehicle. If you have any questions regarding installation or the various components included with the Z1 Motorsports Steering Wheel Airbag Delete Resistors, consult with a Professional Mechanic, or contact Z1 Motorsports for more information.

PARTS INCLUDED:

Item	Quantity	Description
1	2	Airbag Delete Resistor

TOOLS REQUIRED:

- Ratchet
- Ratchet Extension(s)
- Assorted Metric Wrenches
- Assorted Metric Sockets
- Channel Lock Pliers
- Electrical Tape

SAFETY REQUIREMENTS:

- Always wear safety glasses and any necessary protective garments. If using any fluids, chemicals, or solvents, a respirator is recommended.
- Always turn the ignition to the OFF position and disconnect the NEGATIVE battery terminal.
- Always use properly rated jack stands when working under your vehicle.
- Always keep limbs and parts away from moving drivetrain parts.
- Only operate drivetrain in safe space and well-ventilated areas.

BEFORE YOU BEGIN:

Remove contents from the Z1 Motorsports Steering Wheel Airbag Resistors and verify that ALL necessary hardware is present.

PROCEDURE:

1. Refer to your Factory Service Manual (FSM) to remove the Airbag from the Steering Wheel.
2. Disconnect the (2) two connectors attached to the Airbag. *Figure 1* below shows a 370Z Airbag, the process is similar for other vehicles.

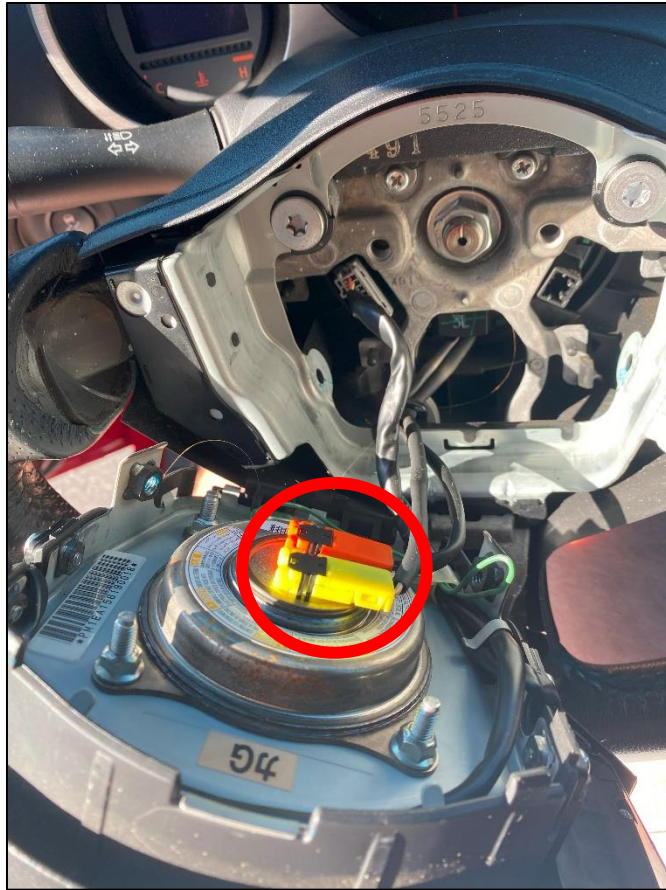

Figure 1

NOTE: The Connectors have a small clip that must be pushed upwards to remove. *Figure 2.*

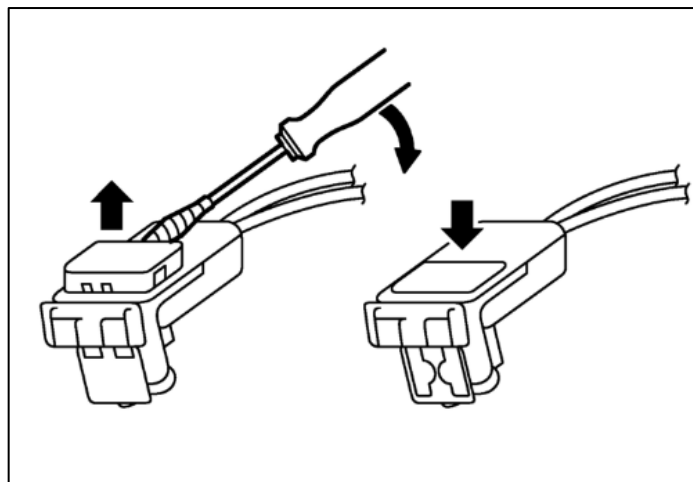

Figure 2

3. Locate the (2) two Airbag Resistors. Plug (1) one into each Airbag Connector removed in *Step 2*. These will prevent the car from throwing an Airbag Code with the OE Airbag removed. *Figure 3*.

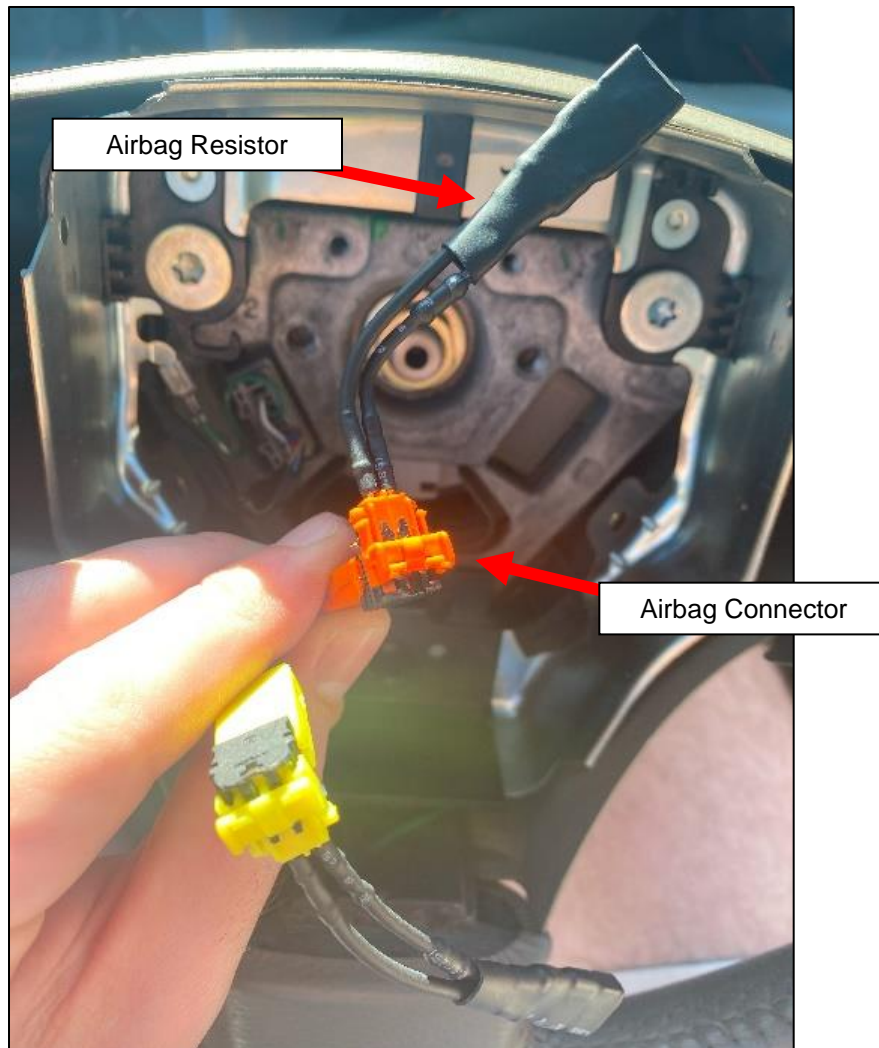

Figure 3

4. Wrap the Connectors and Resistors with electrical tape to prevent them from coming apart. Tuck them into the Steering Wheel Hub after taping.

END

Additional Technical Support:
Contact Z1 Motorsports at info@z1motorsports.com
Or call 770-838-7777 between 9am and 6pm ET