

Z1 VQ35DE ALTERNATOR PULLEY INSTALLATION MANUAL



This Installation Manual is intended for the following models:	
2003-2006	Nissan 350Z
2003-2007	Infiniti G35 (Coupe)
2003-2006	Infiniti G35 (Sedan)

PROLOGUE:

Study these instructions completely before proceeding to assembly. The installer must have a thorough knowledge of automotive systems operation. If unfamiliar with any of the concepts outlined in this instruction, we recommend the installation be completed by a qualified professional.

WARNING!

Extreme caution should be taken when performing maintenance or performance upgrades to your vehicle. Please observe and abide by any Warning or Caution labels placed on the various components and tools used when servicing your vehicle. If you have any questions regarding installation or the various components included with the Z1 Motorsports XX, consult with a Professional Mechanic, or contact Z1 Motorsports for more information.

PARTS INCLUDED:

Item	Quantity	Description
1	1	Alternator Pulley

TOOLS REQUIRED:

- Ratchet
- Ratchet Extension(s)
- Assorted Metric Wrenches
- Assorted Metric Sockets
- Torque Wrench

SAFETY REQUIREMENTS:

- Always wear safety glasses and any necessary protective garments. If using any fluids, chemicals, or solvents, a respirator is recommended.
- Always turn the ignition to the OFF position and disconnect the NEGATIVE battery terminal.
- Always use properly rated jack stands when working under your vehicle.
- Always keep limbs and parts away from moving drivetrain parts.
- Only operate drivetrain in safe space and well-ventilated areas.

BEFORE YOU BEGIN:

Remove contents from the Z1 Motorsports VQ35DE Alternator Pulley and verify that ALL necessary hardware is present.

PROCEDURE:

1. Place the transmission in Park position (or in Reverse gear if equipped with a manual transmission). Apply the parking brake.
2. Raise and support the vehicle with jack and jackstands.
3. Raise and support the hood of the vehicle.
4. Remove Undershroud from vehicle.
5. Loosen the bolt on the Tensioner Pulley from underneath the car. *Figure 1.*

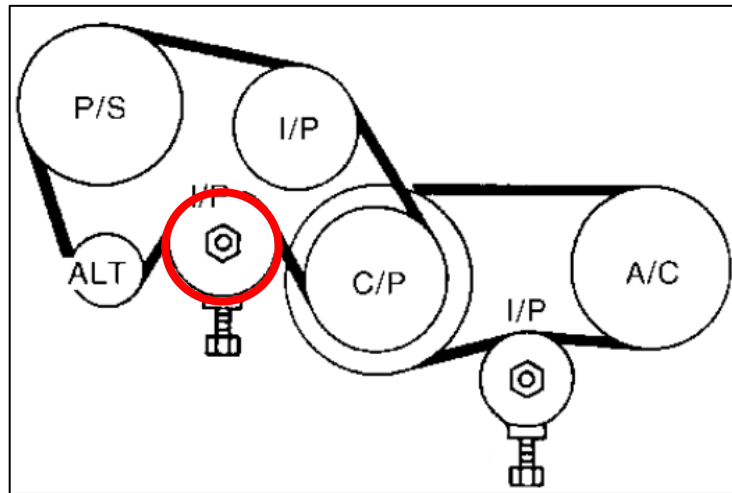

Figure 1

6. Loosen the Belt Tensioner from underneath the car. *Figure 2.*

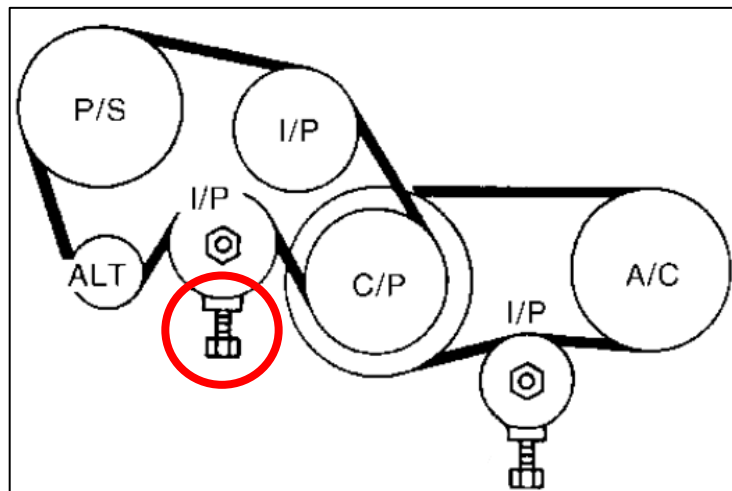

Figure 2

7. Remove the Drive Belt from the Alternator.

8. Locate the Alternator Pulley and remove the nut securing it. *Figure 3.*

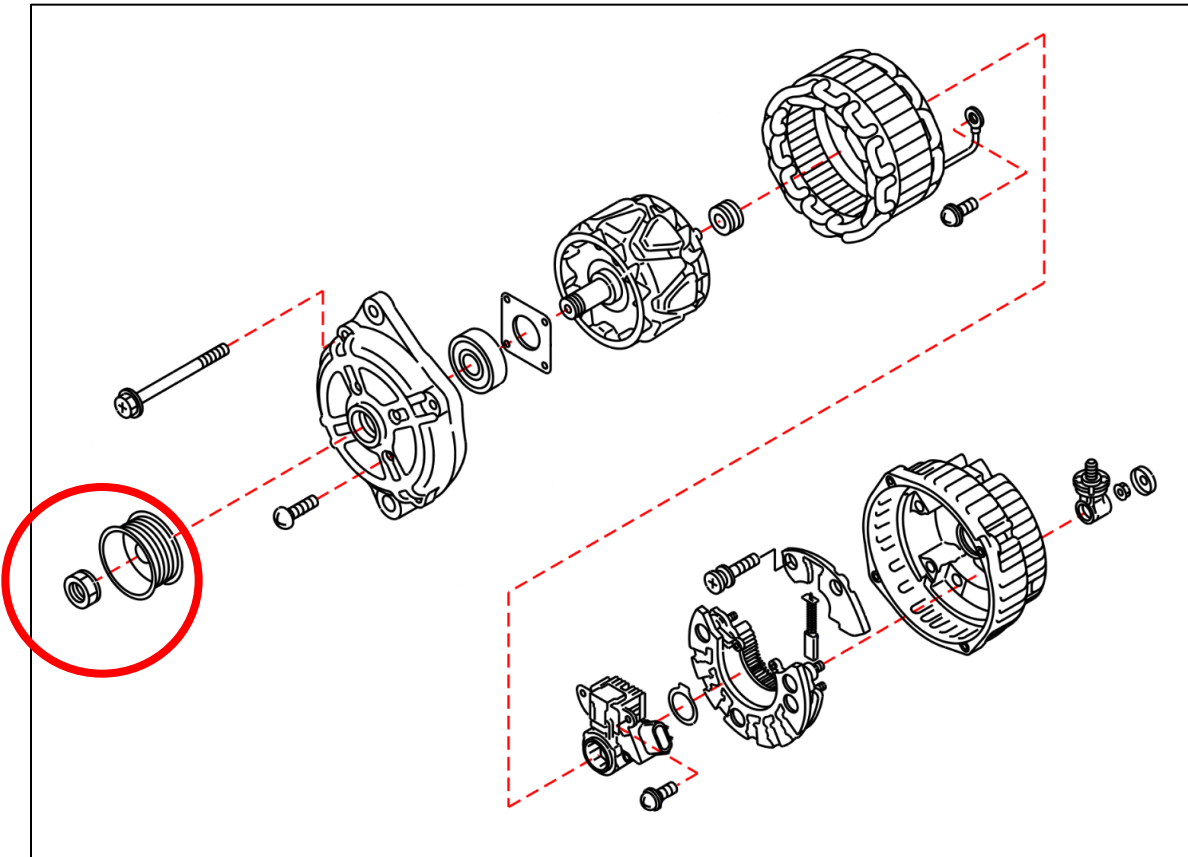

Figure 3

9. Remove the OE Alternator Pulley. *Figure 3.*
10. Install the Z1 Alternator Pulley onto the Alternator.
11. Reinstall the nut removed in *Step 8*. Torque to **87 ft-lbs.**
12. Reinstall the Drive Belt to the Alternator Pulley.
13. Retighten the Drive Belt and Tensioner Pulley from underneath the vehicle.
14. Reinstall the Undershroud.

END

Additional Technical Support:
Contact Z1 Motorsports at info@z1motorsports.com
Or call 770-838-7777 between 9am and 6pm ET