



Kit Contents			
	Description	Part No	Pcs
1	Shock absorber	NIS 5Z00	2
2	Dust boot	10216-01	2
3	Plastic spring spacer	25602-01	4
4	Spring	49200-67	2
5	Upper spring seat	25618-02	2
6	Top pin spacer	24629-13	2
7	Washer	24619-16	2
8	M10 nylon lock nut	24627-01	2
9	Adjustment knob	24631-04	2
10	Nut	04777-02	2
11	Sleeve	24609-01	2
12	Lower spring seat	24635-03	2
13	Lock ring	24636-03	4
14	ABS cord/ Brake hose bracket	25619-03	2
USED FOR BOTH FRONT AND REAR			
	C-spanner	24639-01	1
	C-spanner	24639-04	1
	Öhlins sticker	10207-01	1
	Öhlins owners manual		1

### 👁 Note!

Please note that there can be small differences between your product and the images in these instructions.

### 👁 Note!

Please note that during storage and transport, especially at high ambient temperature, some of the oil and grease used for assembly may leak and stain the packaging. This will not cause damage to the product, wipe off the excessive oil or grease with a cloth.

### 👁 Note!

Before you install this product, check the kit contents. If anything is missing, please contact an Öhlins dealer.

### ⚠ Warning!

Before you install this product, read the Öhlins Owner's manual. This product is an important part of the vehicle and the vehicle stability.

## Shock Absorber Kit for Nissan 370Z (Z34) & Nissan Z (RZ34)

# NIS MZ00S1<sub>front</sub>

## Mounting Instructions



# ÖHLINS

# MOUNTING INSTRUCTIONS

## **⚠ Warning!**

We strongly recommend to let an Öhlins dealer install this product.

## **⚠ Warning!**

If you work with a lifted vehicle, make sure that it is safely supported to prevent it from tipping over.

## **👁 Note!**

When you work with this product, see the vehicle service manual for vehicle specific procedures and important data.

## **👁 Note!**

Before you install this product, clean the vehicle.

**1**

Raise the vehicle and put it on jack stands.

**2**

Remove the front wheels.

**3**

Remove the lower and the upper attachments and remove the original shock absorbers.

**4**

Cut the dust boot (2) 51 mm from the lower end with a pair of scissors according to fig 2.

**5**

Fit the the dust boot (2), the spring (4), the plastic spring spacer (3), the upper spring seat (5), the top pin spacer (6), the OE rubber spring seat, the OE top mount, the washer (7), the M10 nylon lock nut (8) and the adjustment knob (9) according to fig 1. Tighten the M10 nylon lock nut (8) to 35 Nm. Tighten the lower spring seat (12) and the lock ring (13) to 50-60 Nm.

## **👁 Note!**

When tightening the top mount nut, the shock absorber shaft must be held in position with a 5 mm Allen key.

Fig. 1

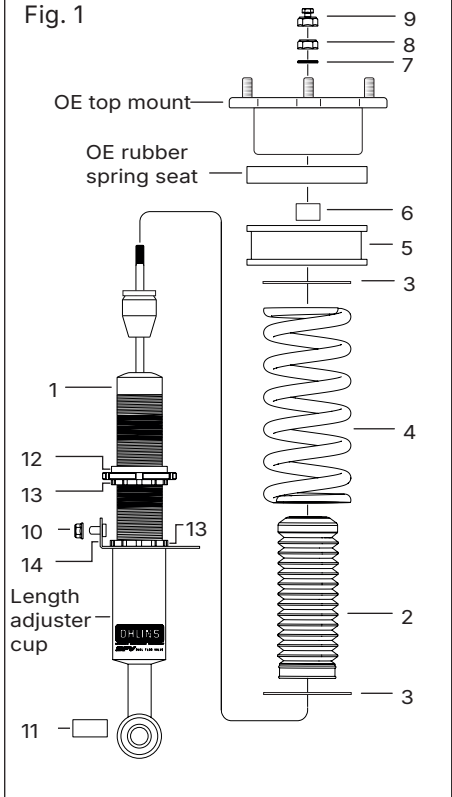
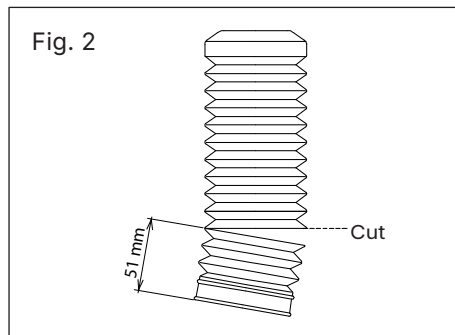

Fig. 2



# MOUNTING INSTRUCTIONS

## 6 For Nissan Z (RZ34)

No ABS cord/Brake hose bracket (14) is needed. Loosen the lock ring (13) with the provided C-spanner and remove the length adjuster cup. Remove the ABS cord/Brake hose bracket (14). Mount the length adjuster cup on the shock absorber (1), and set it to the specified length, see fig 3.

### **⚠ Warning!**

---

*Make sure the length adjuster cup is set according to specification. If damper length is not according to specification, damage to the damper or car can occur resulting loss of control and serious injury. Note that the position of the length adjuster cup is different between the two models!*

---

## 7

Install the Öhlins shock absorber on the vehicle.

## 8

Fasten the upper attachments.

## 9 For Nissan 370Z (Z34)

Mount the original brake hose and the original ABS cord to the ABS cord/Brake hose bracket (14) on the Öhlins shock absorber using the nut (10).

### **👁 Note!**

---

*Make sure that all bolts are tightened to the correct torque and that nothing fouls or restricts movement of the shock absorber when it is being fully compressed or extended.*

---

## 10

Make sure that all removed parts are reinstalled in the same way as they were before the installation of the Öhlins shock absorber.

# ADJUSTMENTS

## ⚠ Warning!

Before driving, always make sure that the basic settings made by Öhlins are according to recommended Set-up Data. Read about adjustments and setting up in the Öhlins Owner's Manual before you make any adjustments. Contact an Öhlins dealer if you have any questions about setting up the shock absorber.

The standard preload is 7 mm from a free length of 200 mm, giving 193 mm installed length, see fig 3.

## SETUP DATA

### Recommended set-up

Setting adjustment		
Street	18	clicks
Track	9	clicks
Spring preload	7	mm
Shock absorber length for 370Z (Z34)	X=55	mm
Shock absorber length for Z (RZ34)	X=57	mm

### Recommended spring

49200-67 (200N/mm)

### The actual vehicle height

With both the preload and height adjustments in their recommended positions, the vehicle is lowered approximately 25 mm when compared to the original suspension. As the lower spring seat is turned one rotation, the position moves 1.5 mm.

Fig. 3

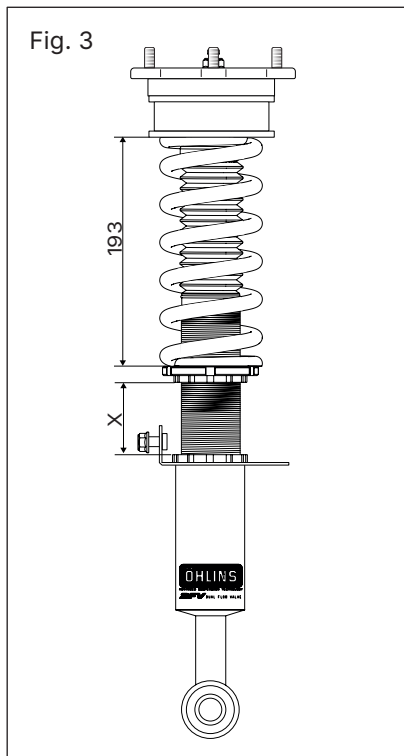

## ⚠ Warning!

The adjustment range is the standard position  $-5 < > +25$  mm. If the length adjuster cup is adjusted outside of this range, permanent damage can occur on the shock absorber or car. Always make sure the spring is pre-loaded when the suspension is fully extended.

Öhlins products are subject to continuous improvement and development, therefore, although these instructions include the most up-to-date information available at the time of printing, minor updates may occur.

To find the latest information contact an Öhlins distributor. Please contact Öhlins if you have any questions regarding the contents in this document.

Part no. MI\_NIS MZ00S1\_front  
Issued 2025-10-30

© Öhlins Group AB. All rights reserved. Any reprinting or unauthorized use without the written permission of Öhlins Group AB is prohibited.

Öhlins Group AB  
Box 722  
S-194 27 Upplands Väsby, Sweden  
Phone +46 8 590 025 00  
fax +46 8 590 025 80





Kit Contents			
	Description	Part No	Pcs
1	Shock absorber	NIS 6Z00	2
2	Dust boot	10216-03	2
3	Ride height adjuster assy	24651-14	2
4	Plastic spring spacer	25602-01	4
5	Spring	49200-43	2
6	M12 nut	24626-04	2
7	M10 nylon lock nut	24626-01	2
8	Tie-rap	24616-01	4
9	Lock ring	24636-03	2

**👁 Note!**

Please note that there can be small differences between your product and the images in these instructions.

**👁 Note!**

Please note that during storage and transport, especially at high ambient temperature, some of the oil and grease used for assembly may leak and stain the packaging. This will not cause damage to the product, wipe off the excessive oil or grease with a cloth.

**👁 Note!**

Before you install this product, check the kit contents. If anything is missing, please contact an Öhlins dealer.

**⚠ Warning!**

Before you install this product, read the Öhlins Owner's manual. This product is an important part of the vehicle and the vehicle stability.

## Shock Absorber Kit for Nissan 370Z (Z34) & Nissan Z (RZ34)

# NIS MZ00S1<sub>rear</sub>

## Mounting Instructions



**ÖHLINS**



# MOUNTING INSTRUCTIONS

**8**  
Bend 3 installation tabs of the upper spring perch according to fig 2. Make sure it does not come in contact with the inner walls of the rear ride height adjuster assy.

**9**  
Install the rear ride height adjuster assy and rubber seat together in the chassis using the provided M8 bolt and M8 nut as shown in fig 2.

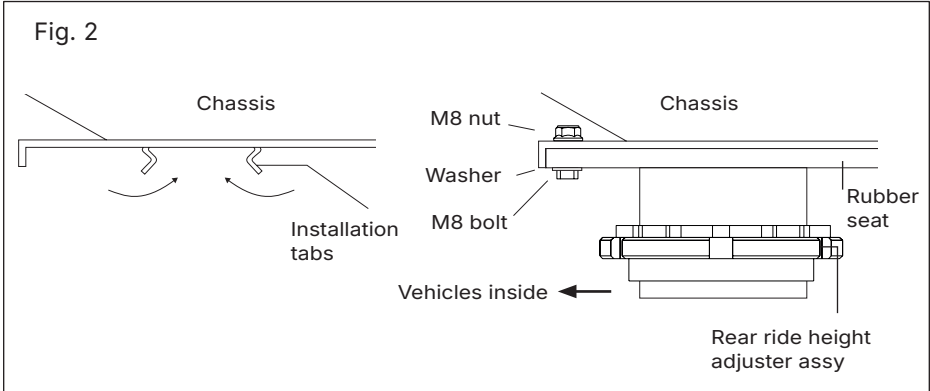

**10**  
Mount the rest of the spring assembly between the upper spring seat and the OE rubber spring seat according to fig 3.

**11**  
Install the Öhlins shock absorbers on the vehicle.

**12**  
Position the top of the dust boot according to fig 4. Tighten the upper tie-rop (8).

**Note!**

*Make sure that all bolts are tightened to the correct torque and that nothing fouls or restricts movement of the shock absorber when it is being fully compressed or extended.*

**13**  
Make sure that all removed parts are reinstalled in the same way as they were before the installation of the Öhlins shock absorber.

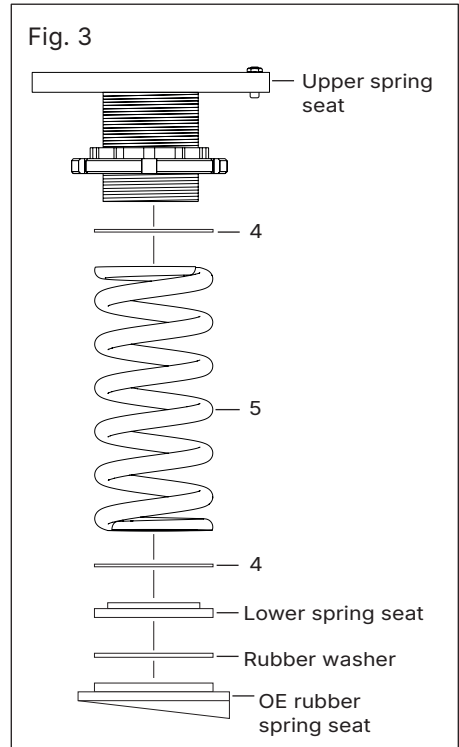

# ADJUSTMENTS

## ⚠ Warning!

Before driving, always make sure that the basic settings made by Öhlins are according to recommended Set-up Data. Read about adjustments and setting up in the Öhlins Owner's Manual before you make any adjustments. Contact an Öhlins dealer if you have any questions about setting up the shock absorber.

## SETUP DATA

### Recommended set-up

Setting adjustment		
Street	15	clicks
Track	7	clicks
Spring adjuster height	11	mm

### Recommended spring

49200-43 (130N/mm)

### The actual vehicle height

With both the preload and height adjustments in their recommended positions, the vehicle is lowered approximately 25 mm when compared to the original suspension. As the height adjuster is turned one rotation, the wheel moves approx. 2.5 mm.

## ⚠ Warning!

The spring preload adjustment range is the standard position approx.  $-10 < +20$  mm. If the spring seat adjuster is moved outside the adjustment range, the spring or spring seat may come loose. Always make sure the spring is pre-loaded when the suspension is fully extended.

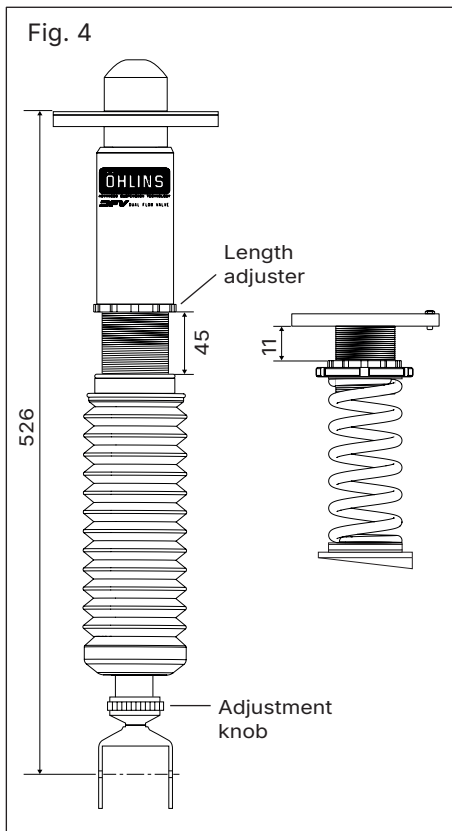

Öhlins products are subject to continuous improvement and development, therefore, although these instructions include the most up-to-date information available at the time of printing, minor updates may occur.

To find the latest information contact an Öhlins distributor. Please contact Öhlins if you have any questions regarding the contents in this document.

Part no. ML\_NIS MZ00S1\_rear  
Issued 2025-10-30

© Öhlins Group AB. All rights reserved. Any reprinting or unauthorized use without the written permission of Öhlins Group AB is prohibited.

Öhlins Group AB  
Box 722  
S-194 27 Upplands Väsby, Sweden  
Phone +46 8 590 025 00  
fax +46 8 590 025 80

