



## Nissan & Infiniti Performance Specialists

2877 Carrollton Villa Rica Hwy Carrollton, GA 30116  
770.838.7777 (PHONE) 770.832.9253 (FAX)  
[www.Z1Motorsports.com](http://www.Z1Motorsports.com)

# Z1 Motorsports 370Z, G37 & GT-R Urethane Motor Mounts



### Parts included:

- 2 Z1 Urethane Motor Mounts (Pre-assembled)
- 1 Z1 Motorsports Urethane Motor Mount Installation Manual

### Applications:

- '09+ Nissan 370Z (Z34)
- '06 – '07 Infiniti G35 (V36)
- '07+ Infiniti G37 (V36)
- '08+ Infiniti G37 (CV36) Coupe
- '08+ Nissan GT-R (R35)

### Note(s):

- All models
- Sedans Only (VQ35HR)
- All models
- All models
- All models

### Suggested Tools:

- Ratchet accessories
- Metric Sockets
- Ratchet Wrench/Air Ratchet
- Torque Wrench

- Metric Allen Wrench Set
- Metric Wrenches
- Safety Glasses

**WARNING!** Use extreme caution when performing ANY maintenance or performance upgrades to your vehicle. Observe and abide by any Warning or Caution labels on the various components and tools used for servicing your vehicle. If you have any questions regarding the installation or the various components included with the Z1 Motorsports Urethane Motor Mounts, consult with a professional mechanic or contact Z1 Motorsports for more information.



***Please note:*** This installation manual is intended to be used as a guide with the installation and servicing of the Z1 Motorsports Urethane Motor Mounts **ONLY**. This manual does not include or offer any suggestions for either removing the engine or replacing the motor mounts while the engine is still installed in the vehicle.



## **BEFORE YOU BEGIN!**

Remove all contents from the Z1 Motorsports Urethane Motor Mount Kit and verify that ALL necessary hardware is present.

## **Installation:**

### **Installation Note #1:**

The Z1 Motorsports Urethane Motor Mounts come pre-assembled from Z1 Motorsports. There is no need to disassemble or service the bushing units prior to installation. If you find that additional height, spacing or adjustment is needed due to a custom installation or application, these motor mounts can be adjusted +0.375" (~10.00 mm) [Raising the motor] and - 0.250" (5.75mm) [Lowering the motor].

Due to limitations and spacing issues between the cross member and the oil pan, as well as other potential alignment concerns on standard applications, the Z1 Motorsports Urethane Motor Mounts should not be lowered further. Do not attempt to modify the mounts in any way beyond what this installation manual details in order to achieve a lower engine height.

- 1) Remove existing motor mounts from the engine. Retain the factory motor mount nuts. **DO NOT DISCARD THESE!**
- 2) Insert the upper motor mount stud into the factory motor mount bracket on the engine block. Tighten the 14mm motor mount nut by hand at this time.
- 3) Keeping in mind such items as the Turbos (on Twin Turbo/GT-R applications), A/C Compressor and brackets, exhaust manifolds/downpipes, etc. Rotate the Z1 Motorsports Urethane Motor Mount so that the access window exposing the 17mm bolt head is easily reached once installed on the motor.

When tightening the both upper and lower mm motor mount nuts, you may find that it is beneficial to insert a 14mm wrench into the opening on the Z1 Urethane Motor Mounts to prevent the internal urethane motor mount bolt from slipping while completing the installation.

- 4) Torque the upper nut to between 36 ft/lbs. It is also recommended that some form of thread locking compound be applied for additional security.

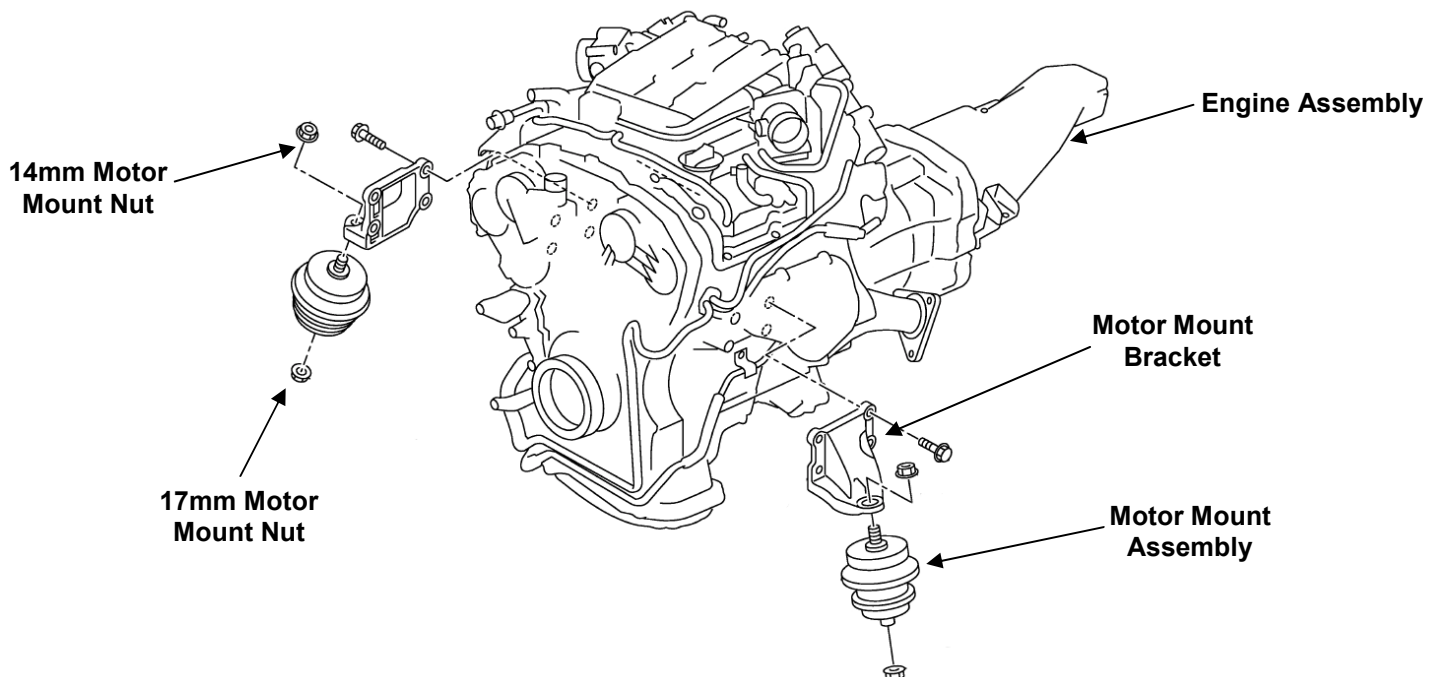

- 5) Once the motor has been reinstalled onto the engine's cross member, torque the lower nut to between 68 ft/lbs. Again, it is recommended that some form of thread locking compound be applied for additional security.

### **Installation Note #2:**

Due to the nature of urethane bushings and its increased stiffness, additional engine vibration will be transferred into the chassis. No additional engine noise or harshness will result of installing the Z1 Motorsports Urethane Motor Mounts.

# Servicing, Disassembly & Reassembly:

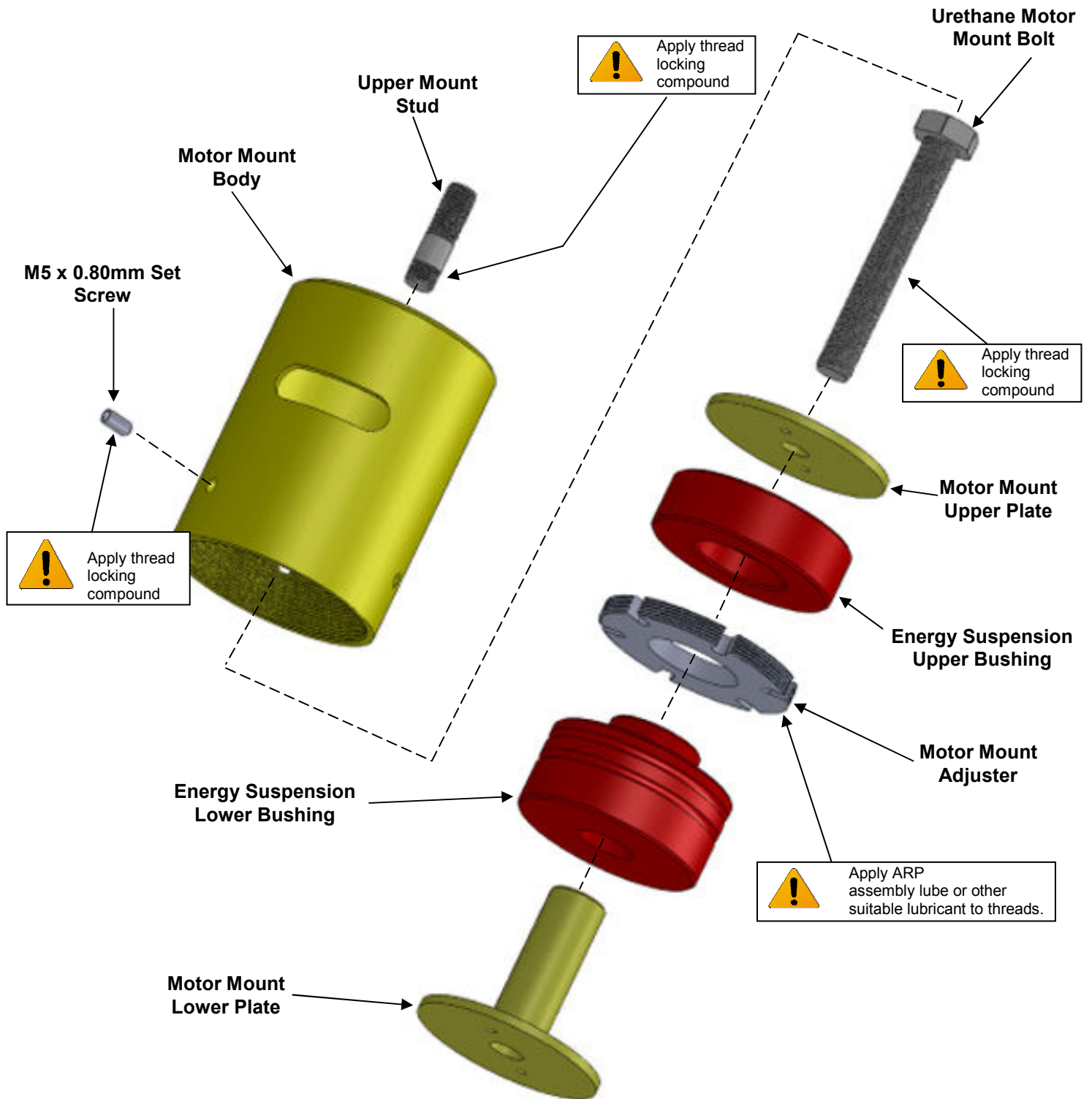

When servicing or adjusting the Z1 Motorsports Urethane Motor Mount Bushings, follow below mentioned steps in sequence when disassembling or reassembling the units. (Refer to the Motor Mount exploded view on the previous page for part sequencing and locations).

### Disassembly:

- 1) **Remove the Motor Mount Lower Plate by unthreading it from the assembly.**

The out rim of the lower plate can be placed into a bench vise. Using a 17mm wrench, insert it into the window on the Motor Mount Body and attach it to the 17mm Motor Mount Bolt. Turn the wrench counter clockwise to loosen the bolt. The entire body assembly will spin, unscrewing the motor mount lower plate.

- 2) **Remove the 17mm wrench from the opening and set aside.**
- 3) **Remove the Energy Suspension Lower Bushing from the Motor Mount Body.**
- 4) **Remove the M5 x 0.80mm Set Screw.**
- 5) **Unscrew the Motor Mount Adjuster from the body.**

***BE CAREFUL NOT TO DAMAGE THE THREADS ON EITHER THE MOTOR MOUNT BODY OR THE MOTOR MOUNT ADJUSTER.***

- 6) **Remove the Energy Suspension Upper Bushing from the Motor Mount Body.**
- 7) **The Urethane Motor Mount Bolt and Upper Plate can remain inside of the Motor Mount Body. Removal is not needed unless to replace a damaged component.**

### Reassembly:

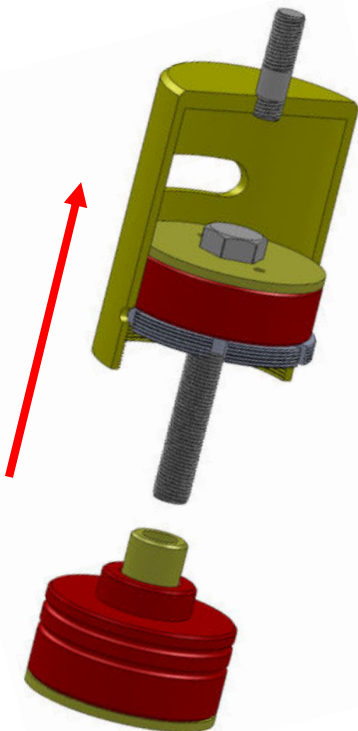

- 1) **Reinstall all previously removed components in the reverse order mentioned above.**

Be sure to lubricate the threads on the Motor Mount Adjuster and those on the Motor Mount Body to ensure smooth travel/engagement. Apply a suitable thread locking compound to the threads on the Motor Mount Bolt.

Screw the Motor Mount Adjuster until it reaches a depth of 9/16" (0.5625") to achieve a factory motor mount height. Re-insert the M5 x 0.80mm Set Screw to prevent the Motor Mount Adjuster from spinning while completing the final steps of assembly.

- 2) **Once all components are reinserted into the Motor Mount Body, use the 14mm Wrench previously used and reinsert it into the Motor Mount Body's window.**
- 3) **Tighten the 17mm Motor Mount Bolt by turning the wrench Clockwise. Tighten the bolt/Motor Mount Body Assembly until the bolt bottoms out.**

By tightening the 17mm Motor Mount Bolt, you are pre-loading the Energy Suspension bushings to the proper specification. Some resistance will be felt as you tighten the bolt. Only when the bolt stops spinning, successfully compressing the upper and lower bushings, will the preload be achieved.