

Z1 350Z / G35 REAR SUBFRAME COLLAR SET INSTALLATION MANUAL



This Installation Manual is intended for the following models:	
2003-2008	Nissan 350Z
2003-2006	Infiniti G35 Sedan
2003-2007	Infiniti G35 Coupe

PROLOGUE:

Study these instructions completely before proceeding to assembly. The installer must have a thorough knowledge of automotive systems operation. If unfamiliar with any of the concepts outlined in this instruction, we recommend the installation be completed by a qualified professional.

WARNING!

Extreme caution should be taken when performing maintenance or performance upgrades to your vehicle. Please observe and abide by any Warning or Caution labels placed on the various components and tools used when servicing your vehicle. If you have any questions regarding installation or the various components included with the Z1 Motorsports 350Z / G35 Rear Subframe Collar Set, consult with a Professional Mechanic or contact Z1 Motorsports for more information.

Parts Included:

Item	Quantity	Description
1	2	Collar A, Rear Lower
2	2	Collar C, Rear Upper
3	2	Collar D, Front Upper
4	2	Collar G, Front Lower

TOOLS REQUIRED:

- Ratchet
- Hydraulic Jack
- (2) 2-Ton (or greater) Jack Stands
- Wheel Chock
- Torque Wrench
- Assorted Metric Sockets

SAFETY REQUIREMENTS:

- Always wear safety glasses and any necessary protective garments. If using any fluids, chemicals, or solvents, a respirator is recommended.
- Always use properly rated jack stands when working under your vehicle.
- Always keep limbs and parts away from moving drivetrain parts.
- Only operate drivetrain in safe space and well-ventilated areas.

BEFORE YOU BEGIN:

Remove contents from the Z1 Motorsports 350Z / G35 Rear Subframe Collar Set and verify that ALL necessary hardware is present.

PROCEDURE:

1. Assure the car's ignition is in the OFF position and the NEGATIVE (-) battery terminal is disconnected.
2. Place the transmission in Park position (or in Reverse gear if equipped with a manual transmission). Apply the parking brake.
3. Raise and support vehicle using jack & jack stands. Locate proper jacking points on vehicle's chassis (refer to vehicle's owner's manual).
4. Remove W-brace (if applicable)
5. Remove exhaust from y-pipe back.
6. Support rear subframe with hydraulic jack.
7. Remove rear brace fasteners from body (if applicable).
8. Remove rear subframe nuts (and brace if applicable).
9. Remove front subframe brackets.
10. Remove front subframe nuts.
11. Lower subframe until you have adequate access to insert the upper collars.

12. Insert front upper collars (collar D).

Note: Be sure collar is pressed completely into the subframe bushing.

13. Insert rear upper collars (collar C).

Note: You will need to rotate this collar so that it is pressed completely into the subframe bushing.

14. Insert front lower collars (collar G).

Note: Be sure collar is pressed completely into the subframe bushing.

15. Insert rear lower collars (collar A).

Note: Be sure collar is pressed completely into the subframe bushing.

16. Raise rear subframe back to factory position.

17. Reinstall rear brace (if applicable).

18. Loosely thread rear subframe nuts onto studs.

19. Reinstall front subframe brackets.

Note: Be careful not to cross thread the front bolts.

20. Loosely thread front subframe nuts onto studs.

21. Torque subframe nuts to 81ft-lbs.

22. Reinstall exhaust.

23. Reinstall W-brace (if applicable).

24. Lower vehicle from jack stands.

25. Perform final test drive of vehicle.

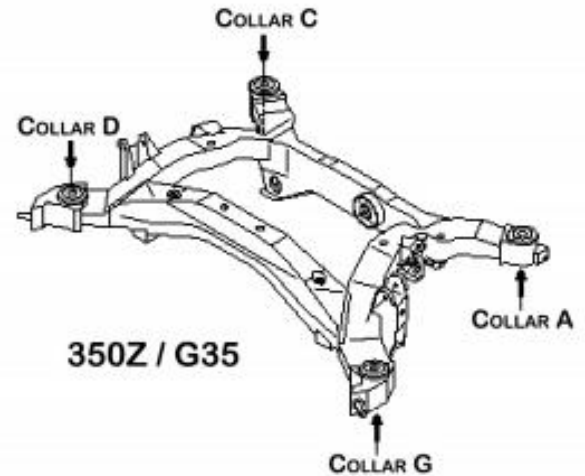

END

Additional Technical Support:
Contact Z1 Motorsports at info@z1motorsports.com
Or call 770-838-7777 between 9am and 6pm ET