

# Z1 370Z / G37 / Z REAR SUBFRAME COLLAR SET INSTALLATION MANUAL



| This Installation Manual is intended for the following models: |                    |
|----------------------------------------------------------------|--------------------|
| 2009-2020                                                      | Nissan 370Z        |
| 2007-2008                                                      | Infiniti G35 Sedan |
| 2009-2013                                                      | Infiniti G37 Sedan |
| 2008-2013                                                      | Infiniti G37 Coupe |
| 2014-2015                                                      | Infiniti Q60 Coupe |
| 2023+                                                          | Nissan Z           |

### PROLOGUE:

Study these instructions completely before proceeding to assembly. The installer must have a thorough knowledge of automotive systems operation. If unfamiliar with any of the concepts outlined in this instruction, we recommend the installation be completed by a qualified professional.

### WARNING!

Extreme caution should be taken when performing maintenance or performance upgrades to your vehicle. Please observe and abide by any Warning or Caution labels placed on the various components and tools used when servicing your vehicle. If you have any questions regarding installation or the various components included with the Z1 Motorsports Rear Subframe Collar Set, consult with a Professional Mechanic or contact Z1 Motorsports for more information.

## **PARTS INCLUDED:**

| Item | Quantity | Description           |
|------|----------|-----------------------|
| 1    | 2        | Collar B, Rear Lower  |
| 2    | 2        | Collar C, Rear Upper  |
| 3    | 2        | Collar E, Front Upper |

## **TOOLS REQUIRED:**

- Hydraulic Jack
- (2) 2-Ton (or greater) Jack Stands
- Ratchet
- Ratchet Extension(s)
- Assorted Metric Sockets/Wrenches
- Torque Wrench

## **SAFETY REQUIREMENTS:**

- Always wear safety glasses and any necessary protective garments. If using any fluids, chemicals, or solvents, a respirator is recommended.
- Always turn the ignition to the OFF position and disconnect the **NEGATIVE** battery terminal.
- Always use properly rated jack stands when working under your vehicle.
- Always keep limbs and parts away from moving drivetrain parts.
- Only operate drivetrain in safe space and well-ventilated areas.

## **BEFORE YOU BEGIN:**

Remove contents from the Z1 Motorsports 370Z / G37 / Z Rear Subframe Collar Set and verify that ALL necessary hardware is present.

## **PROCEDURE:**

1. Place the transmission in Park position (or in Reverse gear if equipped with a manual transmission). Apply the parking brake.
2. Locate proper jacking points on vehicle's chassis (refer to vehicle's Owner Manual). Raise and support vehicle using jack & jack stands.
3. Remove W-brace (if applicable).
4. Remove exhaust from Y-pipe back.
5. Support rear subframe with hydraulic jack.
6. Remove rear brace fasteners from body (if applicable).
7. Remove rear subframe nuts (and brace if applicable).
8. Remove front subframe brackets.
9. Remove front subframe nuts.
10. Lower subframe until you have adequate access to insert the upper collars.

11. Insert front upper (Top) collars (collar E).

**Note:** Be sure the collar is pressed completely flush into the subframe bushing.

12. Insert rear upper (Top) collars (collar C).

**Note:** You will need to rotate this collar so that it is pressed completely flush into the subframe bushing.

13. Insert rear lower bottom collars (collar B).

**Note:** Be sure collar is pressed completely flush into the subframe bushing.

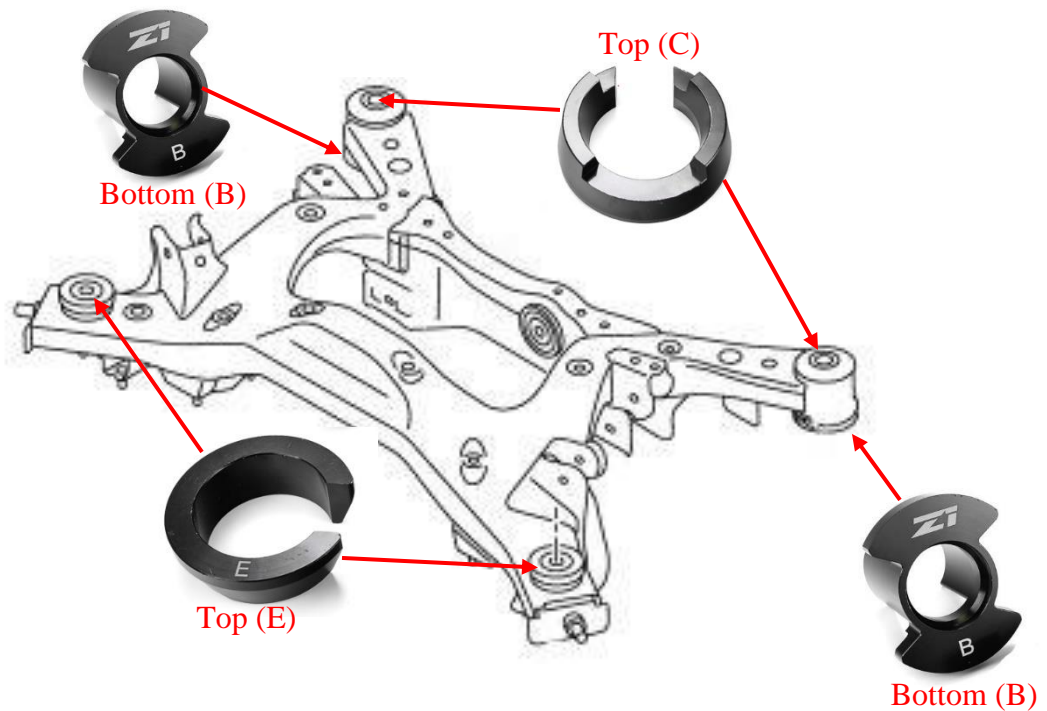

14. Raise rear subframe back to factory position.

15. Reinstall rear brace (if applicable).

16. Reinstall front subframe brackets.

**Note:** Be careful not to cross thread the front bolts.

17. Reinstall subframe nuts. Torque to **81ft-lbs**.

18. Reinstall exhaust.

19. Reinstall W-brace (if applicable).

20. Lower vehicle from jack stands.

21. Perform final test drive of vehicle.

**END**

**Additional Technical Support:**  
Contact Z1 Motorsports at [info@z1motorsports.com](mailto:info@z1motorsports.com)  
Or call 770-838-7777 between 9am and 6pm ET