

Z1 370Z / G37 / Z REAR TRACTION ARM SET INSTALLATION MANUAL



This Installation Manual is intended for the following models:	
2009-2020	Nissan 370Z
2008-2015	Infiniti G37 Coupe
2009-2015	Infiniti G37 Sedan
2023+	Nissan Z

PROLOGUE:

Study these instructions completely before proceeding to assembly. The installer must have a thorough knowledge of automotive systems operation. If unfamiliar with any of the concepts outlined in this instruction, we recommend the installation be completed by a qualified professional.

WARNING!

Extreme caution should be taken when performing maintenance or performance upgrades to your vehicle. Please observe and abide by any Warning or Caution labels placed on the various components and tools used when servicing your vehicle. If you have any questions regarding installation or the various components included with the Z1 Motorsports 370Z / G37 / Z Rear Traction Arm Set, consult with a Professional Mechanic or contact Z1 Motorsports for more information.

PARTS INCLUDED:

Item	Quantity	Description
1	1	Red Loctite
Track Version Traction Arms will provide the following:		
2	2	Pre-assembled Traction Arm with Solid Heim Joint Assembly
Street Version Traction Arms will provide the following:		
3	2	Pre-assembled Traction Arm with Urethane Bushing Assembly

TOOLS REQUIRED:

- Hydraulic Jack
- (2) 2-Ton (or greater) Jack Stands
- Ratchet
- Ratchet Extension(s)
- 17mm Socket/Wrench
- 19mm Socket/Wrench
- Torque Wrench
- Crescent Wrench

SAFETY REQUIREMENTS:

- Always wear safety glasses and any necessary protective garments. If using any fluids, chemicals, or solvents, a respirator is recommended.
- Always turn the ignition to the OFF position and disconnect the NEGATIVE battery terminal.
- Always use properly rated jack stands when working under your vehicle.
- Always keep limbs and parts away from moving drivetrain parts.
- Only operate drivetrain in safe space and well-ventilated areas.

BEFORE YOU BEGIN:

Remove contents from the Z1 Motorsports 370Z / G37 / Z Rear Traction Arm Set and verify that ALL necessary hardware is present.

PROCEDURE:

1. Place the transmission in Park position (or in Reverse gear if equipped with a manual transmission). Apply the parking brake.
2. Release tension to lug nuts at rear wheels. DO NOT remove lug nuts!
3. Locate proper jacking points on vehicle's chassis (refer to vehicle's Owner Manual). Raise and support vehicle using jack & jack stands.
4. Remove rear wheel and lug nuts.
5. Locate OEM traction arms located at left & right, connecting rear knuckle to sub-frame (circled at right).
6. Remove the bolt that attaches OEM traction arm to sub-frame.

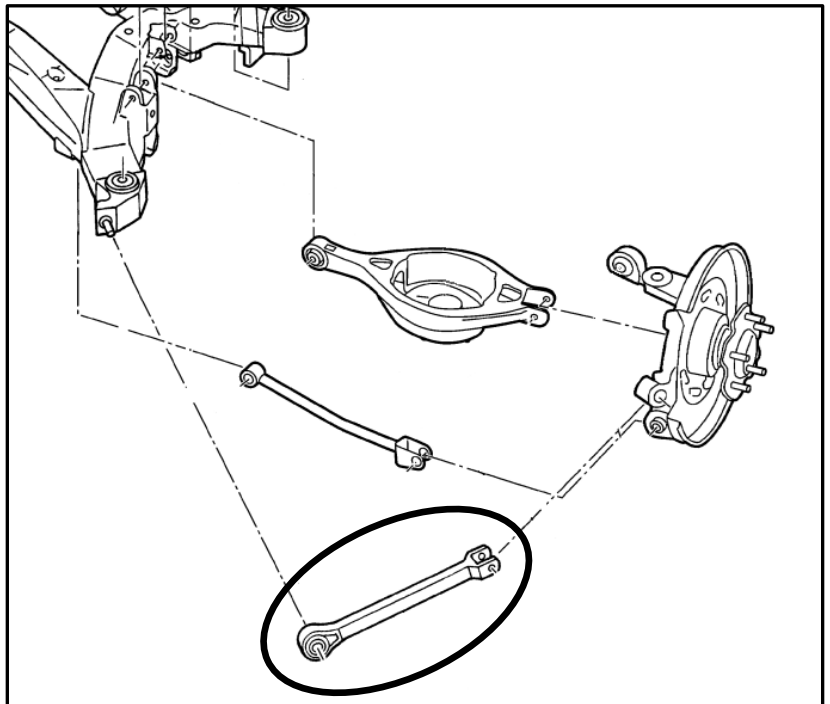

7. Remove bolt that attaches OEM traction arm to rear knuckle.
8. Remove OEM traction arm from vehicle.
9. Locate Z1 traction arms. Thread each end completely inside body. Set Z1 traction arm next to OEM traction arm and adjust length to match (270mm from eye-to-eye, as shown).

Note: assure exposed threads at each end does not exceed 15mm. Note: assure that ends remain stationary while body is rotated.

10. Once length is set, apply red thread locker to exposed threads nearest to control arm. Thread jam nut over thread locker and tighten against control arm.
11. Position Z1 traction arm into sub-frame. Install bolt and torque to 54ft-lbs.

Note: If equipped with street version bushings, assure serviceable grease fittings face downward.

Note: Z1 Street Version Traction Arms come equipped with serviceable grease fittings. It is recommended that you add grease after installation and every 5,000 miles to assure long product life. Z1 recommends use of Energy Suspension Formula 5 Prelube or other synthetic water-resistant marine-grade grease.

12. Position Z1 traction arm fork onto mounting hole of rear knuckle. Install bolt and torque to 65ft-lbs.
13. Install rear wheel and lug nuts.
14. Repeat steps 5-13 for opposite side of vehicle.
15. Lower vehicle from jack stands.
16. Torque lug nuts to 80ft-lbs.
17. Perform alignment check & adjust traction arms accordingly.
18. Perform a final test drive of the vehicle.

END

Additional Technical Support:

Contact Z1 Motorsports at info@z1motorsports.com
Or call 770-838-7777 between 9am and 6pm ET