



## Z32 Upgraded Hatch Strut Kit Installation Manual



### **PROLOGUE:**

Study these instructions completely and thoroughly before proceeding to assemble. Installation can be completed using common tools and automotive procedures. The installer must have a thorough knowledge of automotive systems operation. If unfamiliar with any of the concepts outlined in this instruction, we recommend the installation be completed by a qualified professional.

**WARNING!:** Extreme caution should be taken when performing ANY maintenance or performance upgrades to your vehicle. Please observe and abide by any Warning or Caution labels placed on the various components and tools used when servicing your vehicle. If you have any questions regarding the installation or the various components included with the Z1 Motorsports Z32 Upgraded Hatch Strut Kit, consult with a Professional Mechanic or contact Z1 Motorsports for more information.

## **Parts List:**

- Mounting Ball Studs (4 pcs)
- Hatch Strut Assembly (2 pcs, includes upper mounting stud and socket ends)
- Locking Pin (2 pcs)

## **Tools Required:**

- 12mm open end wrench
- Hatch support (anything or anyone who will support Hatch safely while Struts are replaced).

## **Safety Requirements:**

- Always wear safety glasses and any necessary protective garments. If using any fluids, chemicals, or solvents, a respirator is recommended.
- Always turn the ignition to the OFF position and disconnect the NEGATIVE battery terminal.

## **\*BEFORE YOU BEGIN!**

***Remove contents from the Z1 Motorsports Z32 Upgraded Hatch Strut Kit and verify that ALL necessary hardware is present.***

## **Installation:**

1. Unlatch, raise, and safely support Rear Hatch.
2. Remove Upper Strut Ball End Stud from Hatch side.

**Note:** Ball Ends do not separate from OEM Strut.

3. Remove Lower Strut Ball End Stud from Chassis.

**Note:** Retain OEM washers.

4. Remove OEM Hatch Strut Assembly.
5. Locate (2) Z1 Mounting Ball Studs. Swap OEM washers onto Studs.
6. Thread Lower Strut Ball End Stud into Hatch at OEM location. Tighten to 9-11 ft-lbs.
7. Thread Upper Strut Ball End Stud into Hatch at OEM location. Tighten to 9-11 ft-lbs.

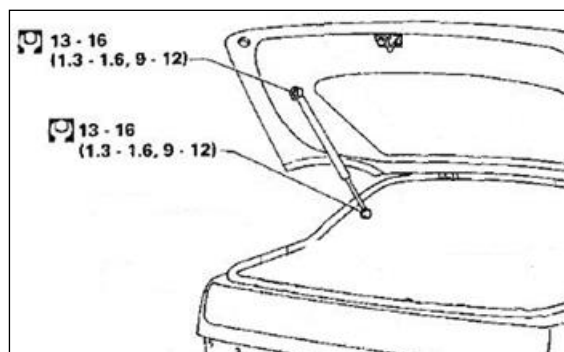

8. Locate Z1 Upgraded Hatch Strut Assembly. Place Strut to OEM location on vehicle.

Note: Mount chrome rod end to Chassis-side.

Note: Socket Ends of Hatch Strut Assembly should ‘**snap**’ onto Ball. Tap back of Assembly onto Ball until snaps into place.

9. Install Locking Pin. See diagram below:

- a. Insert Locking Pin “B” through hole on Assembly “A”.
- b. Rotate Locking Pin and snap into place, locking assembly.

Note: Do not bend Locking Pin.



10. Repeat steps # 2-9 for opposite side Hatch Strut Assembly.

11. Slowly Lower Z32 Hatch. Check for fitment and smooth operation.

**End**

**Additional Technical Support:**

Contact Z1 Motorsports at [info@z1motorsports.com](mailto:info@z1motorsports.com)

Or call 770 838 7777 between 9am and 6pm ET